

Surface Mount

Chip Resistor



Surface mount chip resistors are available in three different terminal styles for either RF or DC applications, such as bias voltage dropping or heaters. Terminal Style A has a full backside metallization for direct attachment to a heat sink or an item to be heated. Terminal Style B has wrap-around divider for low power SMT applications. Terminal Style C has a split ground that allows it be mounted as a resistor or termination. This style provides a larger ground area for increased heat dissipation and is an excellent choice for high power SMT applications.

Specifications

Standard Resistance	50 & 100 Ohms $\pm 5\%$
Resistance Range	3 to 400 Ohms
Power	2 to 800 Watts
Power Rating	100% @ 100°C
Derates to	0% @ 150°C
Operating Temperature	-55°C to 150°C
Substrate	BeO, AlN or Alumina
Resistive Element	Thin or Thick Film
Solderable Terminals	See Plating Option
Environment	Meets applicable sections of MIL-PRF-55342

Power Rating and Derating

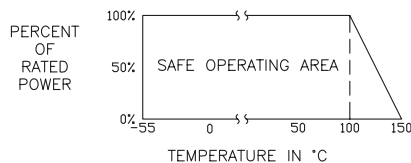

Part Numbering Code

8	1	A	7	0 4 2	—	1 0 0	—	5	F
STYLE 8 = Chip/ Power Pak	PLATING OPTION — = Tin Lead ^{†1} A = Silver Nickel B = Silver Copper M = Non-magnetic	DESCRIPTIONS Random Numbers	TYPE 1 = Resistor	SUBSTRATE MATERIAL 7 = Aluminum Nitride 8 = Alumina 3 = Beryllium Oxide	RESISTANCE Value in ohms — = Tin/Lead (blank) = RoHS Compliant	TOLERANCE 1 = 1% 2 = 2% 5 = 5% 10 = 10%	ENVIRONMENTAL COMPLIANCE F = RoHS Compliant		
					(blank) = Style C A = Style A B = Style B				

^{†1} Not RoHS Compliant

Style A

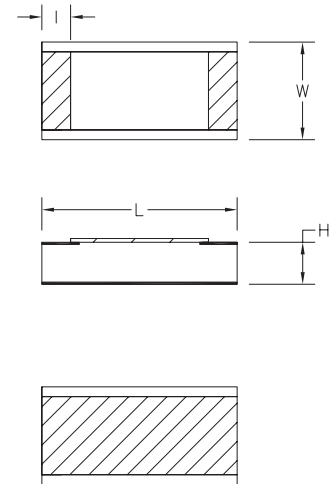

Style B

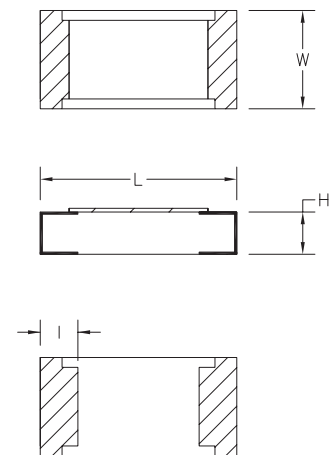

Style C

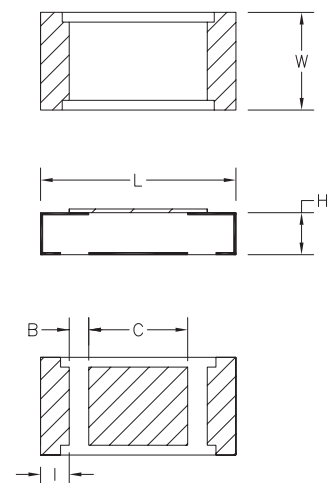



Surface Mount

Product Information

Power	Resistance	Substrate	Capacitance	L		W		H		Part Series #
Watt	Range			mm [inches]						
2	10-250	Alumina	0.10	3.05	[0.120]	1.52	[0.060]	0.38	[0.015]	81 8004B*
5	25-200	Alumina	0.10	5.08	[0.200]	2.54	[0.100]	1.02	[0.040]	81 8002B*
5	25-200	AlN	0.27	5.08	[0.200]	2.54	[0.100]	1.02	[0.040]	81 7001B*
5	2.5-200	BeO	0.80	5.08	[0.200]	2.54	[0.100]	1.02	[0.040]	81 3001B*
6	5-150	BeO	/1	5.08	[0.200]	5.08	[0.200]	1.02	[0.040]	81 3002Bv
8	3-200	BeO	0.66	6.35	[0.250]	6.35	[0.250]	1.57	[0.062]	81 3012B*
8	5-75	BeO	0.85	5.84	[0.230]	8.89	[0.350]	1.02	[0.040]	81 3005B*
8	3-200	BeO	1.00	6.35	[0.250]	6.35	[0.250]	1.02	[0.040]	81 3003B*
10	10-300	AlN	/1	5.08	[0.200]	2.54	[0.100]	1.02	[0.040]	81 7031*
10	15-400	BeO	0.10	5.08	[0.200]	2.54	[0.100]	1.02	[0.040]	81 3031*
10	7-250	BeO	1.33	9.53	[0.375]	6.35	[0.250]	1.02	[0.040]	81 3006B*
10	5-200	BeO	0.80	5.08	[0.200]	2.54	[0.100]	1.02	[0.040]	81 3001A*
10	10-300	AlN	0.10	5.08	[0.200]	2.54	[0.100]	1.02	[0.040]	81 7031
12	5-250	BeO	1.64	9.53	[0.375]	9.53	[0.375]	1.02	[0.040]	81 3008B*
15	5-150	BeO	/1	5.08	[0.200]	5.08	[0.200]	1.02	[0.040]	81 3002A*
20	15-300	AlN	1.50	9.53	[0.375]	6.35	[0.250]	1.02	[0.040]	81 7042
20	5-75	BeO	6.00	6.35	[0.250]	6.35	[0.250]	1.02	[0.040]	81 3039*
20	7-250	BeO	1.50	9.53	[0.375]	6.35	[0.250]	1.02	[0.040]	81 3032*
30	5-120	BeO	0.85	5.84	[0.230]	8.89	[0.350]	1.02	[0.040]	81 3005A*
50	5-200	AlN	/1	9.53	[0.375]	9.53	[0.375]	1.02	[0.040]	81 7028*
50	10-400	BeO	1.35	17.78	[0.700]	8.89	[0.350]	1.52	[0.060]	81 3036*
50	5-120	BeO	1.00	6.35	[0.250]	6.35	[0.250]	1.02	[0.040]	81 3003A*
100	12-400	BeO	4.48	25.40	[1.000]	25.40	[1.000]	1.52	[0.060]	81 3011B*
150	7-250	BeO	1.33	9.53	[0.375]	6.35	[0.250]	1.02	[0.040]	81 3006A*
250	5-200	BeO	/1	9.53	[0.375]	9.53	[0.375]	1.02	[0.040]	81 3028*
800	12-400	BeO	4.48	25.40	[1.000]	25.40	[1.000]	1.52	[0.060]	81 3011A*

Peak power is typically 10 times the max power rating with a 1% duty cycle and 10 microsecond pulse width.

/1 Varies by resistance value within the range. Call the Sales department for more information.

“**” is a place holder. See part number configurations to complete the part number.

For L, B and C dimensions see data sheet on website.