

TITLE: SPECIFICATION CONTROL DRAWING

PART IDENTIFIER: SMT3737A

DESCRIPTION: SURFACE MOUNT TERMINATION, THICK FILM ALUMINA

ASSEMBLY DWG: 1101714

1.0 SPECIFICATIONS:

1.1 ELECTRICAL:

1.1.1 IMPEDANCE: 50Ω NOMINAL.

1.1.2 FREQUENCY: DC – 2.5 GHZ.

1.1.3 VSWR: 1.35:1 MAX.

1.1.4 INPUT POWER:

1.1.4.1 25 WATTS. CHIP SOLDERED TO MOUNTING SURFACE. MOUNTING SURFACE TEMPERATURE MAINTAINED AT 100 °C MAXIMUM. APPLY LINEAR DE-RATING OF INPUT POWER TO 0 WATTS AT 150 °C.

1.2 MECHANICAL:

1.2.1 OUTLINE DWG: SEE SHEET 2.

1.2.2 WORKMANSHIP: PER MIL-PRF-55342

1.2.3 THERMAL IMPEDANCE (R_θ)

1.2.3.1 0.500 °C / WATT R_θ FROM RESIST FILM TO MOUNTING SURFACE DIRECTLY UNDER CENTER OF CHIP. CHIP SOLDERED DIRECTLY TO MOUNTING SURFACE.

1.2.4 FILM TEMPERATURE (T_F)

1.2.4.1 200 °C ABSOLUTE MAXIMUM FILM TEMPERATURE. DE-RATE TO 150 °C MAXIMUM FILM TEMPERATURE FOR ALL MILITARY/HIGH-RELIABILITY APPLICATIONS.

1.2.5 THERMAL

1.2.5.1 DETERMINE MAXIMUM MOUNTING SURFACE TEMPERATURE BY APPLYING THE FOLLOWING FORMULA:
 $T_s = T_f - (P_{MAX} \times R_{\theta})$

WHERE: T_S = MAXIMUM MOUNTING SURFACE TEMPERATURE

T_F = MAXIMUM FILM TEMPERATURE

P_{MAX} = MAXIMUM APPLIED INPUT POWER

R_θ = CHIP THERMAL IMPEDANCE.

1.3 ENVIRONMENTAL:

1.3.1 TEMPERATURE RANGE:

1.3.1.1 NON-OPERATING: -55 °C TO +150 °C.

1.3.1.2 OPERATING: -55 °C TO +150 °C.

2.0 UNIT MARKING: NONE.

3.0 QUALITY ASSURANCE:

3.1 SAMPLE INSPECT PER ANSI/ASQC Z1.4 GENERAL INSPECTION, LEVEL II, AQL = 1.0.

3.1.1 VISUAL AND MECHANICAL PER 824W154.

3.1.2 DC RESISTANCE: 50Ω ± 5%.

3.2 DATA REQUIREMENTS:

3.2.1 NO TEST DATA REQUIRED FOR CUSTOMER.

3.2.2 DATA RETENTION – 24 MONTHS.

4.0 PACKAGING: STANDARD PACKING PER 755W002.

EMC TECHNOLOGY 8851 SW OLD KANSAS AVE. STUART, FL 34997	CAGE CODE # 24602		DWG #	1010205000
	CHANGE NOTICE	EN 08-E0534	REV LVL	A
			SHEET	1 OF 2

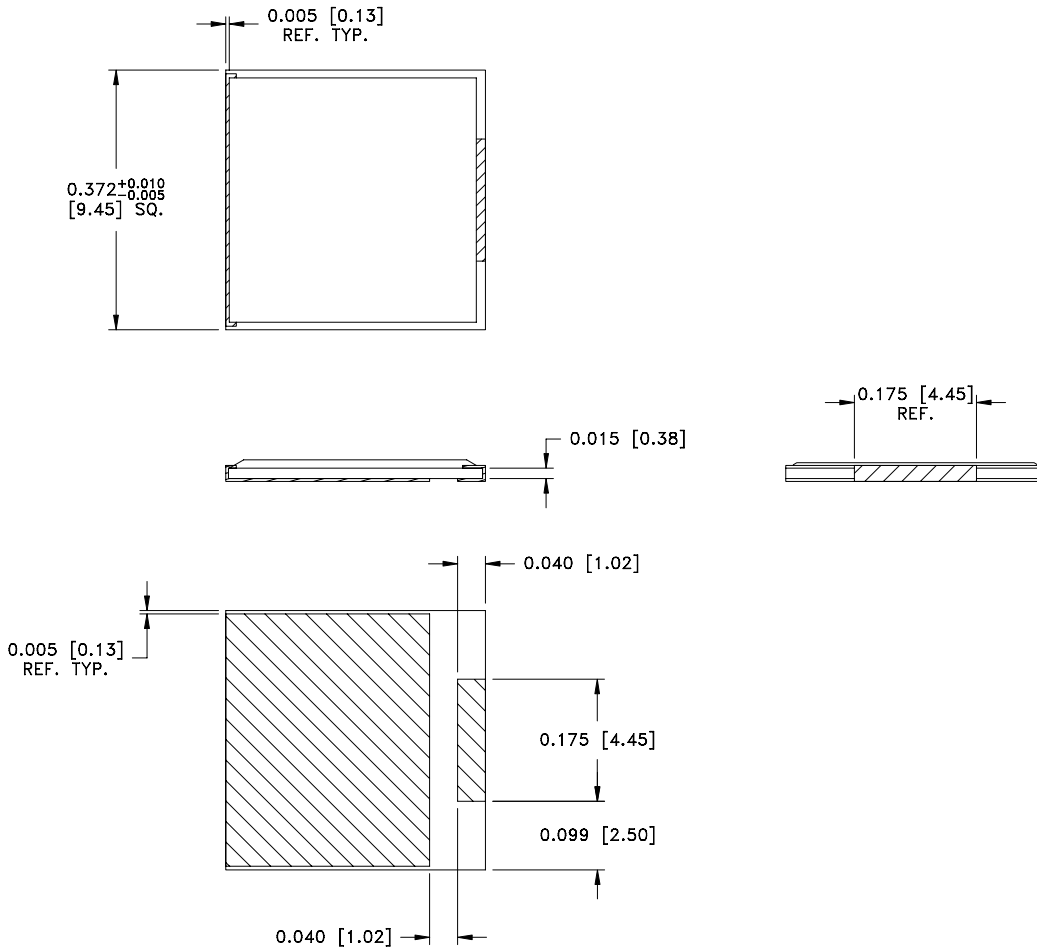

MECHANICAL SPECIFICATIONS

SUBSTRATE:
MATERIAL - ALUMINA, MIL-I-10.
TERMINAL:
MATERIAL - THICK FILM, NICKEL BARRIER,
SOLDER PLATED.
RESIST:
MATERIAL - THICK FILM.

METRIC EQUIVALENTS GIVEN IN [mm]
FOR REFERENCE INFORMATION ONLY

POWER RATING AND DERATING

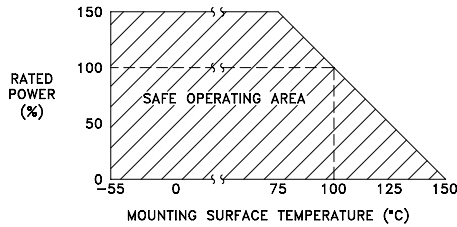

EMC
Technology
8851 SW OLD KANSAS AVE
STUART, FL 34997
PHONE NO. (772)286-9300
FAX NO. (772)283-5286

UNLESS OTHERWISE SPECIFIED DIMENSIONS ARE IN INCHES		THESE DRAWINGS AND SPECIFICATIONS ARE THE PROPERTY OF EMC TECHNOLOGY INC AND SHALL NOT BE DUPLICATED OR USED AS BASIS FOR THE MANUFACTURE OR SALE OF PARTS OR DEVICES WITHOUT PERMISSION.				
<u>TOLERANCES</u>		CAGE CODE	SCALE	DRAWN BY	CHECKED BY	APPROVED BY
FRACT	---	24602	6:1	JG 7/7/08		
ANG	---					
XX	---					
XXX	±0.005					
XXXX	---					
REV	CHANGE NOTICE	DRAWING NO	SHEET			
A	EN 08-E0534	1010205000	2 OF 2			