

Coaxial Couplers

UHF to Ku-Band Coaxial Couplers

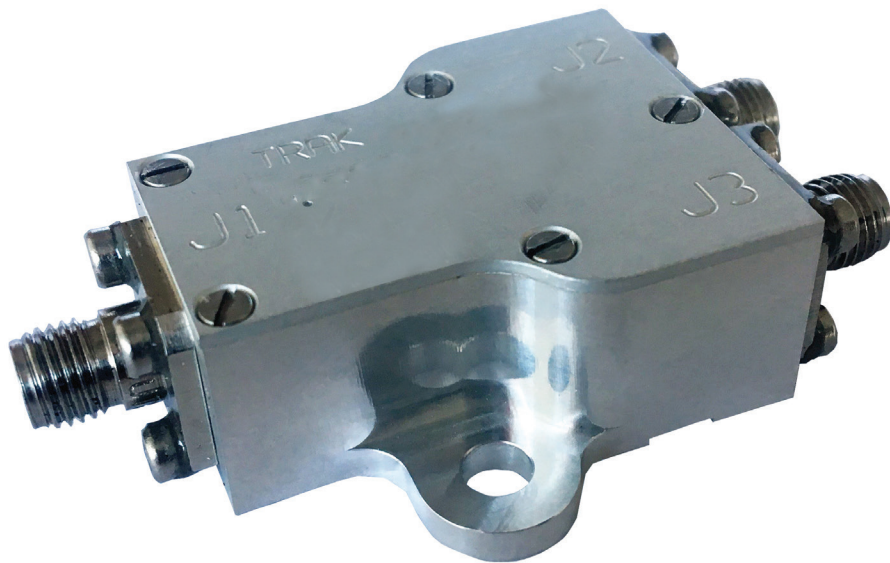

UHF to Ku-Band Coaxial Couplers

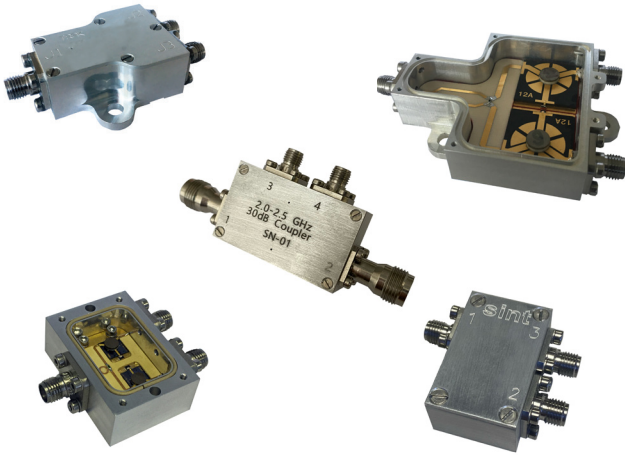

Smiths Interconnect's broad range of passive coaxial couplers include Wilkinson, Directional and Branchline devices designed specifically to provide optimal performance in assigned frequencies from UHF to Ku-Band.

Smiths Interconnect's coaxial couplers provide designers and system architects with reliable and robust products designed and qualified for extreme operating environments in the Space, Avionics and Defence markets.

Our stand-alone coaxial couplers leverage the company's internal design, manufacturing, and Environmental Stress Screening (ESS) capabilities to support spacecraft applications including launch vehicles and payloads in GEO/MEO and LEO orbits.

Beyond offering couplers as components Smiths Interconnect can provide couplers incorporated within more complex passive assemblies, including ferrite isolators and RF filters, to offer solutions that optimise performance, volume, and mass.

Broad range of coaxial couplers for proven reliability applications

Features & Benefits

- Robust and mass minimised range of couplers
- Optimised electrical performance
- Space qualified: vibration, thermal cycling, mechanical shock and where appropriate high power testing (including multipaction where required)
- Environmentally robust EMC shielding
- Connectors selected based on operating frequency and RF power
- Internal terminations and resistors analysed to maintain reliability under fault conditions
- Couplers can be supplied as stand-alone components or integrated with Smiths Interconnect's ferrite isolators and RF filters

Applications

- GEO/MEO & LEO payloads
- Single and re-useable launch systems
- Ground, airborne, and naval systems

UHF Branchline (quadrature) Coupler

Designed for spacecraft and launch vehicle applications

Specifications

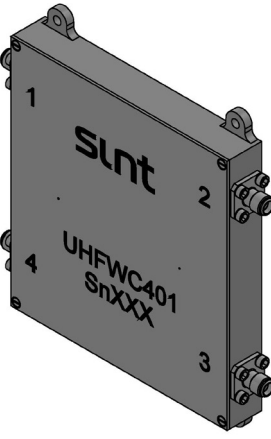
	UHF Power Divider	Performance
	Part Number	UHFWC301
	Function	Quadrature coupler
	Operating Frequency	375 to 450Mz
	Qualification Temperature	-45 to +95C
	Acceptance Temperature	-35 to +85C
	Insertion Loss (includes coupling loss)	0.35dB max
	Amplitude Balance	+/-0.2dB
	Inter Channel isolation	20 dB min
	Return Loss	20 dB min

- Can be supplied with 4 ports accessible (illustrated) or with one port suitably terminated
- Supplied with SMA connectors as standard
- TNC interfaces may be appropriate for higher power applications

UHF Wilkinson Power Divider, 1:2

Designed for spacecraft and launch vehicle applications

Specifications

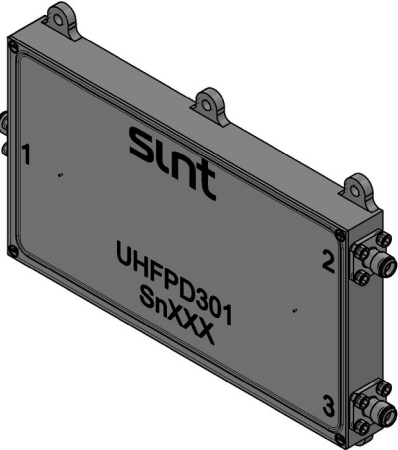
	UHF Branchline Coupler	Performance
	Part Number	UHFPDx01
	Function	Power splitter
	Operating Frequency	375 to 450Mz
	Qualification Temperature	-45 to +95C
	Acceptance Temperature	-35 to +85C
	Insertion Loss (includes coupling loss)	3.30dB max
	Amplitude Balance	+/-0.2dB
	Inter channel isolation	20 dB min
	Return Loss	20 dB min
Power Handling	10W CW	

- Supplied with SMA connectors as standard
- TNC interfaces may be appropriate for higher power applications

L-Band Branchline (quadrature) Coupler

Designed for spacecraft and launch vehicle applications

Specifications

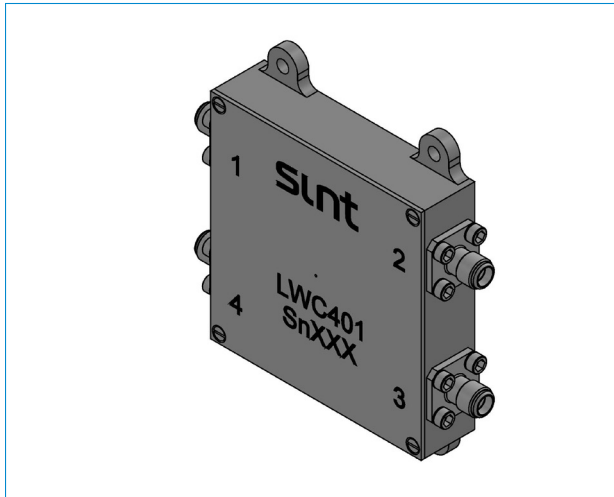

L-Band Coupler	Performance
Part Number	LWC401
Function	Quadrature Coupler
Operating Frequency	1540 to 1620MHz
Qualification Temperature	-45 to +95C
Acceptance Temperature	-35 to +85C
Insertion Loss (includes coupling loss)	3.30dB max
Amplitude Balance	+/-0.2dB
Return Loss	20 dB min
Power Handling	3W CW

- Can be supplied with 4 ports accessible (illustrated) or with one port suitably terminated
- Supplied with SMA connectors as standard
- TNC interfaces may be appropriate for higher power applications

L-Band Bi-Directional Coupler

Designed for terrestrial and airborne applications

Specifications

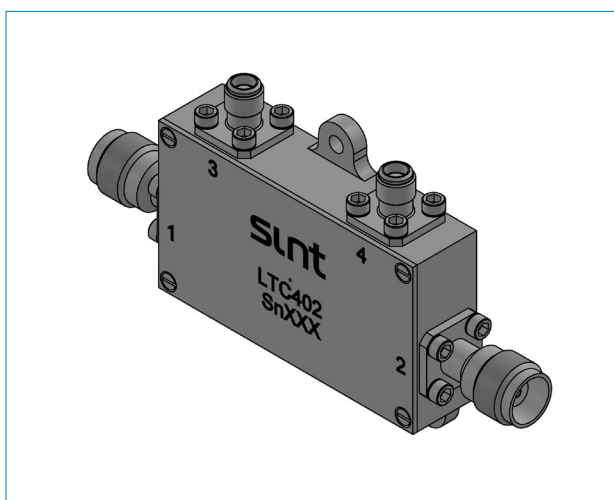

L-Band Coupler	Performance
Part Number	LTCx01
Function	Directional Coupler
Operating Frequency	1020 to 1100MHz
Qualification Temperature	-45 to +95C
Acceptance Temperature	-35 to +85C
Insertion Loss	0.35dB max
Coupling	30+/-1dB
Directivity	20 dB min
Isolation	50 dB+/-1dB
Return Loss (all ports)	20 dB min

- Can be supplied with 4 ports accessible (illustrated) or with one coupled port suitably terminated
- Supplied with SMA (LTC401), TNC (LTC402) or N-Type interfaces (LTC403) depending on RF power

S-Band Wilkinson Power Divider, 1:2

Designed for spacecraft applications

Specifications

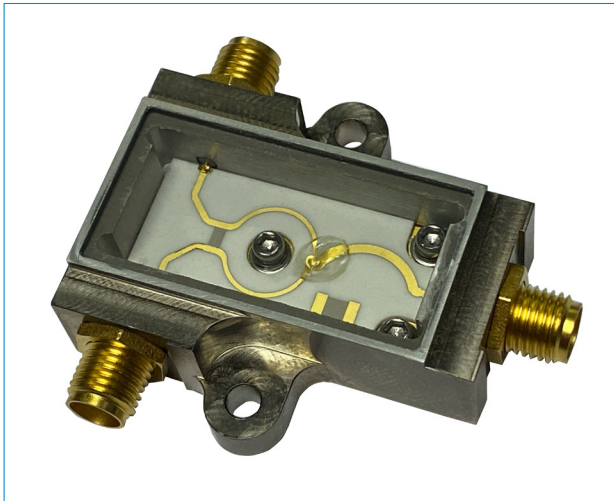

S-Band Power Divider	Performance
Part Number	SPD301
Function	Power Splitter
Operating Frequency	2000 to 2500MHz
Qualification Temperature	-55 to +125C
Acceptance Temperature	-50 to +85C
Amplitude Balance	+/-0.1dB
Insertion Loss (includes coupling loss)	3.40dB max
Inter Channel Isolation	23 dB min
Return Loss	19 dB min
Power Handling	2W CW

- Supplied with spark plug hermetic SMA connectors as standard
- Phase matched outputs

S-Band Wilkinson Power Divider, 1:2

Designed for spacecraft applications

Specifications

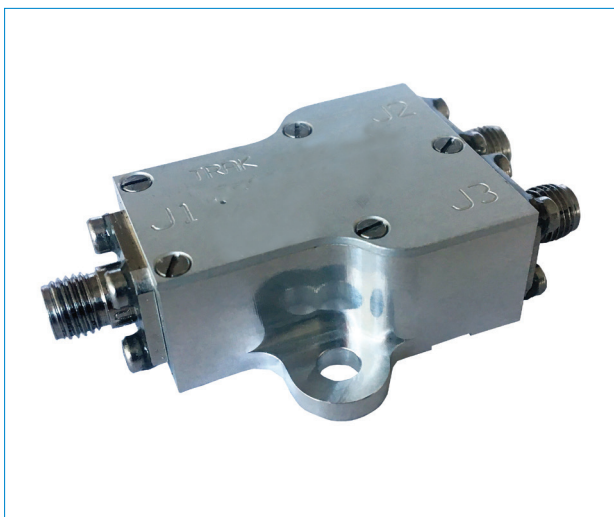

S-Band Power Divider	Performance
Part Number	SPD302, SPD303
Function	Power Splitter
Operating Frequency	2300 to 2400MHz
Qualification Temperature	-45 to +95C
Acceptance Temperature	-20 to +75C
Insertion Loss	3.50dB max
Amplitude Balance	+/-0.2dB
Inter Channel Isolation:	20 dB min (SPD302) 40 dB min (SPD303)
Return Loss (all ports)	20 dB min
Power Handling	3W CW

- Supplied with SMA connectors as standard
- Can be integrated with our substantial range of TT&C qualified ferrite isolators or circulators. Internal ferrite isolators included in the SPD303

S-Band isolator 6-Channel Power Divider

Designed for spacecraft applications

Specifications

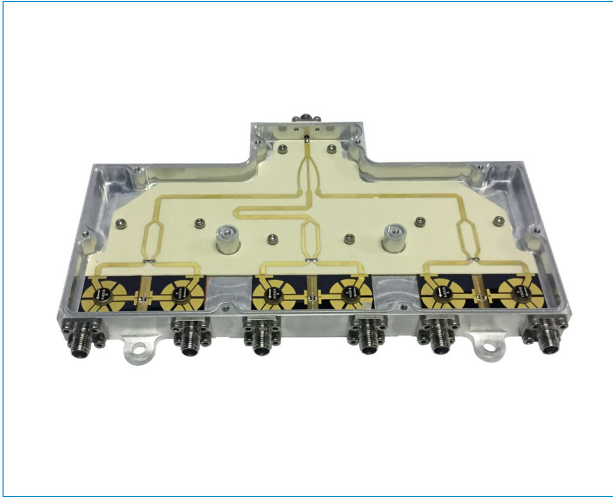

S-Band Power Divider	Performance
Part Number	SPD701
Function	Power Splitter
Operating Frequency	2300 to 2400Mz
Qualification Temperature	-45 to +95C
Acceptance Temperature	-20 to +75C
Insertion Loss (includes coupling loss)	9.0dB max
Amplitude Balance	+/-0.7dB
Return Loss (all ports)	23 dB min
Power Handling	6W CW

- 6-way isolated power divider. Each channel includes a ferrite isolator on the output
- Channels are phase and group delay matched
- Supplied with SMA connectors as standard

S-Band Directional Coupler

Designed and qualified for space applications

Specifications

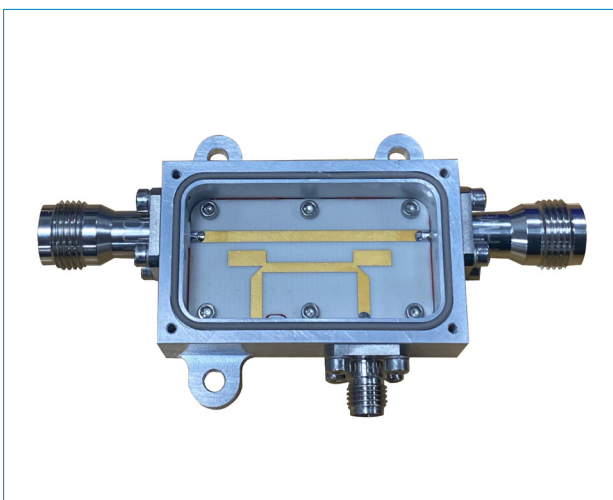

S-Band Coupler	Performance
Part Number	STC401
Function	Test Coupler
Operating Frequency	2000 to 2200MHz
Qualification Temperature	-45 to +95C
Acceptance Temperature	-35 to +85C
Insertion Loss	0.30dB max
Coupling	30+/-1dB
Directivity	18 dB min
Return Loss (all ports)	20 dB min
Power Handling	150W CW

- Can be supplied with all ports accessible or with one coupled port suitably terminated (illustrated)
- Supplied with TNC connectors as standard
- SMA interfaces may be appropriate for lower power applications
- Can be integrated with our substantial range of ferrite isolators or band defining RF filters

S-Band Bi-Directional Coupler

Designed and qualified for spacecraft applications

Specifications

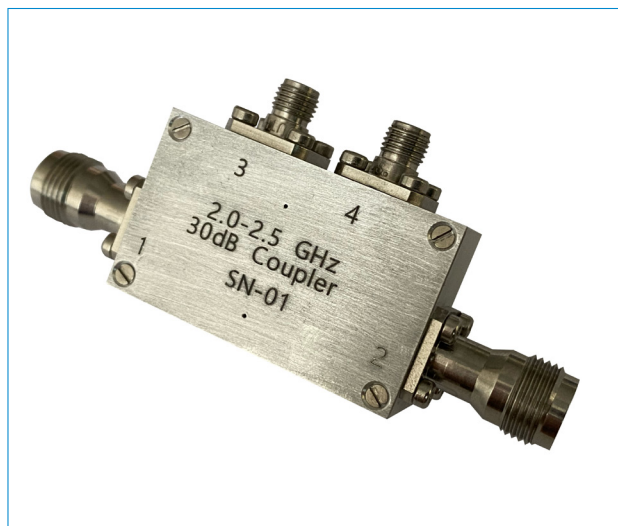

S-Band Directoinal Coupler	Performance
Part Number	STC402
Function	Test Coupler
Operating Frequency	2000 to 2200MHz
Qualification Temperature	-45 to +95C
Acceptance Temperature	-20 to +75C
Insertion Loss	0.30dB max
Coupling	30+/-1dB
Directivity	18 dB min
Isolation	48dB+/-1 dB min
Return Loss (all ports)	20 dB min
Power Handling	150W CW

- Can be supplied with 4 ports accessible (illustrated) or with one coupled port suitably terminated
- Supplied with TNC connectors as standard. SMA interfaces may be appropriate for lower power applications
- Can be integrated with our substantial range of ferrite isolators or band defining RF filters

C-Band Wilkinson Power Divider 1:2

Designed for spacecraft and terrestrial radar applications

Specifications

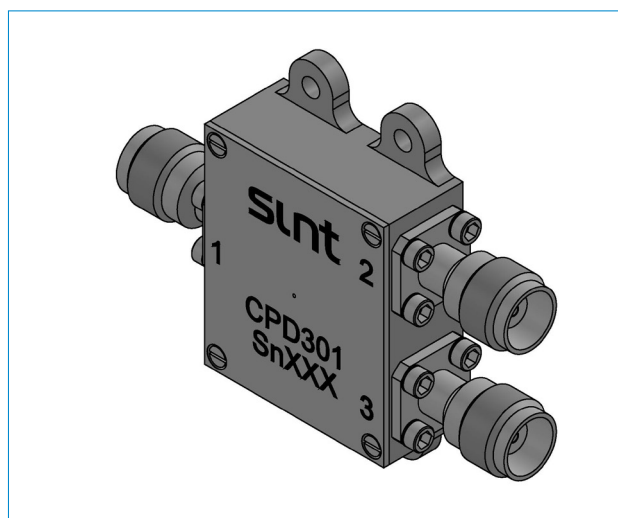

C-Band Divider	Performance
Part Number	CPD301
Function	Power Splitter
Operating Frequency	5200 to 5900MHz
Qualification Temperature	-45 to +95C
Acceptance Temperature	-35 to +85C
Insertion Loss (includes coupling loss)	0.40dB max
Amplitude balance	+/-0.2dB
Inter Channel Isolation	18 dB min
Return Loss	18 dB min
Power Handling	50W CW

- Supplied with TNC connectors as standard. SMA interfaces may be appropriate for lower power applications
- Can be integrated with our substantial range of ferrite isolators or band defining RF filters

C-Band Directional Coupler

Designed and qualified for spacecraft applications

Specifications

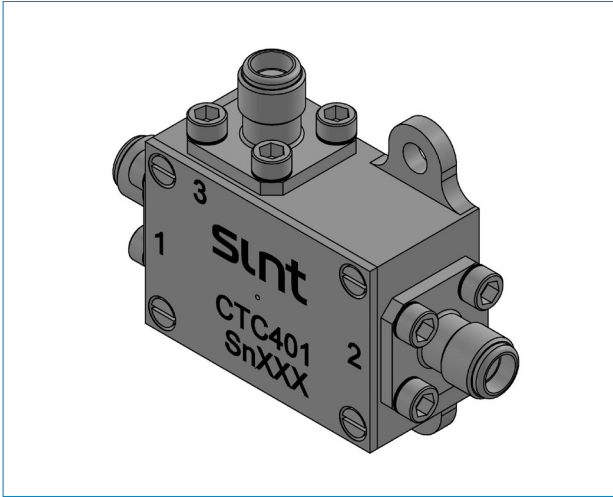

C-Band Directional Coupler	Performance
Part Number	CTC401
Function	Test Coupler
Operating Frequency	3400 to 4200MHz
Qualification Temperature	-45 to +95C
Acceptance Temperature	-35 to +85C
Insertion Loss	3.50dB max
Coupling	20+/-1dB
Directivity	20 dB min
Return Loss (all ports)	18 dB min
Power Handling	3W CW

- Can be supplied with all ports accessible or with one coupled port suitably terminated (illustrated)
- Supplied with SMA as standard. TNC connectors employed for higher power versions
- Can be integrated with our substantial range of ferrite isolators or band defining RF filters

C-Band Branchline (quadrature) Coupler

Designed and qualified for spacecraft applications

Specifications



C-Band Coupler	Performance
Part Number	CWC402
Function	Coupler
Operating Frequency	3400 to 4200MHz
Qualification Temperature	-45 to +95C
Acceptance Temperature	-35 to +85C
Insertion Loss (includes coupling loss)	3.50dB max
Amplitude balance	+/-0.3dB
Return Loss	18 dB min
Power Handling	3W CW

- Can be supplied with all ports accessible or with one coupled port suitably terminated (illustrated)
- Supplied with SMA as standard. TNC connectors employed for higher power versions
- Can be integrated with our substantial range of ferrite isolators or band defining RF filters

Ku-Band Isolated Wilkinson Power Divider

Designed and qualified for spacecraft applications

Specifications

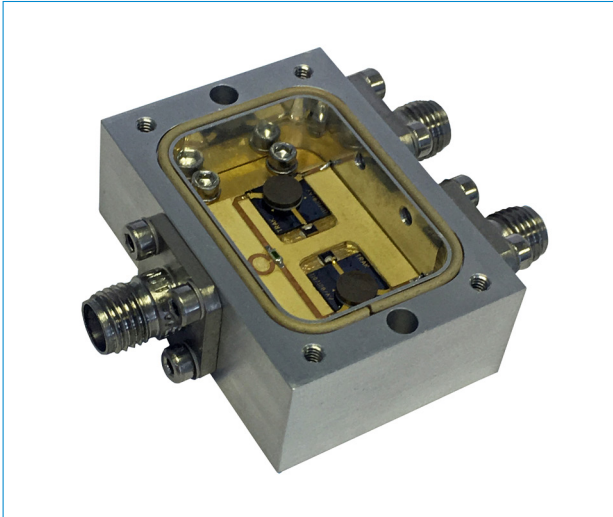

Ku-Band Power Divider	Performance
Part Number	XPD301
Function	Divider
Operating Frequency	12.7 to 14.8GHz
Qualification Temperature	-45 to +95C
Acceptance Temperature	-35 to +85C
Insertion Loss (includes coupling loss)	3.40dB max
Amplitude Balance	+/-0.2dB
Inter Channel Isolation	40 dB min
Return Loss	18 dB min
Power Handling	3W CW

- Supplied with SMA connectors as standard
- Isolators included on output ports

Ku-Band Branchline (quadrature) Coupler

Designed and qualified for spacecraft applications

Specifications

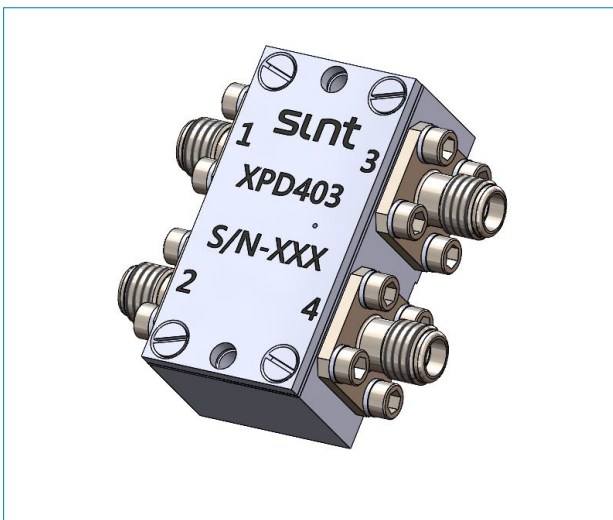

Ku-Band Coupler	Performance
Part Number	XTC401
Function	Quadrature Coupler
Operating Frequency	10.7 to 11.7GHz
Qualification Temperature	-45 to +95C
Acceptance Temperature	-35 to +85C
Insertion Loss (includes coupling loss)	3.80dB max
Directivity	18dB min
Directivity	18dB min
Return Loss (all ports)	18dB min
Power Handling	3W CW

- Can be supplied with 4 ports accessible (illustrated) or with one coupled port suitably terminated
- Supplied with SMA as standard. TNC connectors employed for higher power versions
- Can be integrated with our substantial range of ferrite isolators or band defining RF filters

Related Products

Smiths Interconnect can provide a wide array of passive products which, in combination, can improve microwave and RF coaxial system performance. The following are examples of products that are being supplied with the couplers featured within.

High Power Circulator, C2022/A

Designed for TT&C applications

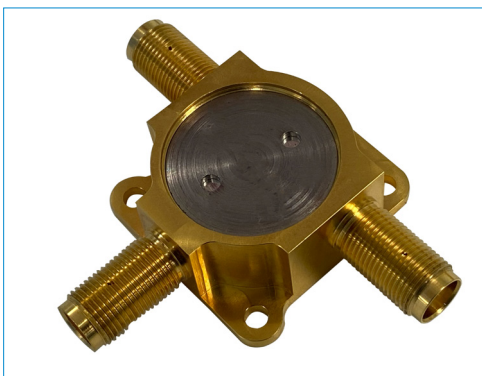

High Power Circulator	Performance
Function	Circulator
Operating Frequency	2.00 to 2.20 GHz
Storage Temperature	-55 to +125C
Acceptance Temperature	-15 to +55C
Insertion Loss	0.20dB max
Return Loss	20 dB min
Power Handling	150 CW

- Multipactor free / Corona Discharge free Circulator used in launch applications under full fault conditions; full reflection any phase
- Used as a duplexer or available as an isolator in conjunction with an integrated or remote TNC remote termination

High Power Circulator, C03743/A

Designed and qualified for UHF proximity transceiver

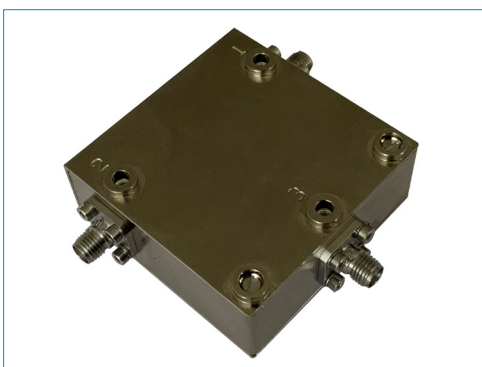

High Power Circulator	Performance
Function	Circulator
Operating Frequency	375 to 450 MHz
Storage Temperature	-55 to +125C
Operating Temperature	-35 to +85C
Insertion Loss	0.5dB max
Return Loss	20dB min
Power Handling	10W CW

- Multipactor free / Corona Discharge free Circulator used in launch applications under full fault conditions; full reflection any phase
- Used as a duplexer or available as an isolator in conjunction with an integrated or remote TNC remote termination

Additional Test Capabilities

Smiths Interconnect can provide a wide array of add-on test services to suit market and program needs. Below is a list of standard available test options. Please consult factory for individual program needs.

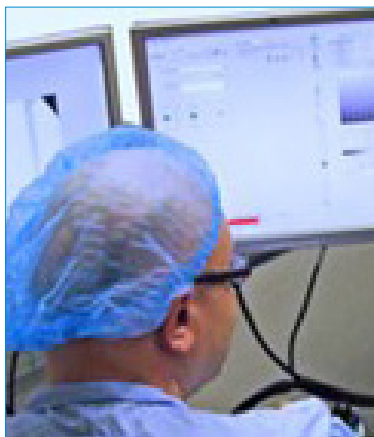

Qualification and Test Laboratory in Dundee, Scotland

Features

- 300 square metres of modern and purpose built lab space
- All rooms with independent air conditioning and temperature control
- Dedicated ISO8 clean room for Seeded Multipaction, Corona & High-power thermal vacuum test from 200 MHz to 22GHz
- SRS mechanical shock test (Q= 10)

Per MIL, ESA or Custom Test and Inspection Standards

SRS Mechanical Shock Test to 5000g	Thermal Cycle and Shock Testing
Optical Inspection to 200x	RF Power Withstanding (Facility Ranges from 200MHz to 22.2GHz)
3D X-Ray Tomography and Inspection	Radio Active Seeded Multipaction Testing
Random and Sine Vibration Testing	Corona Discharge (Critical power) Testing
Gross Leak Testing	VNA Testing to 110GHz
Voltage Withstanding and Insulation Testing	Automated Bondpull Testing
Continuous Insertion Phase and Amplitude Monitoring	Barometric Pressure (Altitude) Testing

Worldwide Support

Connectors

Americas

Sales

connectors.uscsr@smithsinterconnect.com

Technical Support

connectors.ustechsupport@smithsinterconnect.com

Europe

Sales

connectors.emeacsr@smithsinterconnect.com

Technical Support

connectors.emeatechsupport@smithsinterconnect.com

Asia

Sales

asiacsr@smithsinterconnect.com

Technical Support

asiatechsupport@smithsinterconnect.com

Fibre Optics & RF Components

Americas

Sales

focom.uscsr@smithsinterconnect.com

Technical Support

focom.techsupport@smithsinterconnect.com

Europe

Sales

focom.emeacsr@smithsinterconnect.com

Technical Support

focom.techsupport@smithsinterconnect.com

Asia

Sales

focom.asiacsr@smithsinterconnect.com

Technical Support

focom.techsupport@smithsinterconnect.com

Semiconductor Test

Americas

Sales

semi.uscsr@smithsinterconnect.com

Technical Support

semi.techsupport@smithsinterconnect.com

Europe

Sales

semi.emeacsr@smithsinterconnect.com

Technical Support

semi.techsupport@smithsinterconnect.com

Asia

Sales

semi.asiacsr@smithsinterconnect.com

Technical Support

semi.techsupport@smithsinterconnect.com

RF/MW Subsystems

Americas, Europe & Asia

Sales

subsystems.csr@smithsinterconnect.com

Technical Support

subsystems.techsupport@smithsinterconnect.com

Connecting Global Markets

more > [smithsinterconnect.com](https://www.smithsinterconnect.com) | [in](#) [twitter](#) [youtube](#)

Copyright© 2022 Smiths Interconnect | All rights reserved | Version 1.0

The information contained within this document is subject at all times to applicable Export Control regulations and legal requirements.