

TITLE: SPECIFICATION CONTROL DRAWING

PART IDENTIFIER: CT2335S

DESCRIPTION: HIGH POWER CHIP TERMINATION, BERYLLIA

ASSEMBLY DWG: 1101824

1.0 SPECIFICATIONS:

- 1.1 ELECTRICAL:
 - 1.1.1 IMPEDANCE: 50Ω NOMINAL.
 - 1.1.2 FREQUENCY: DC - 4 GHZ.
 - 1.1.3 VSWR: 1.25:1 MAX.
 - 1.1.4 INPUT POWER:
 - 1.1.4.1 HEAT SINK 100°C: 100 WATTS (DERATE POWER LINEARLY TO 0 WATTS @ 125°C).
- 1.2 MECHANICAL:
 - 1.2.1 OUTLINE DWG: SEE SHEET 2.
 - 1.2.2 WORKMANSHIP: PER MIL-STD-454, REQUIREMENT 9.
- 1.3 ENVIRONMENTAL:
 - 1.3.1 TEMPERATURE RANGE:
 - 1.3.1.1 NON-OPERATING: -55°C TO +150°C.
 - 1.3.1.2 OPERATING: -55°C TO +125°C.

2.0 UNIT MARKING: NONE.

3.0 QUALITY ASSURANCE:

- 3.1 SAMPLE INSPECT PER ANSI/ASQC Z1.4 GENERAL INSPECTION, LEVEL II, AQL = 1.0.
 - 3.1.1 VISUAL AND MECHANICAL PER 824W154.
 - 3.1.2 DC RESISTANCE: 50Ω ± 5%.
- 3.2 DATA REQUIREMENTS:
 - 3.2.1 NO TEST DATA REQUIRED FOR CUSTOMER.
 - 3.2.2 DATA RETENTION - STANDARD.

4.0 PACKAGING: STANDARD PACKING PER 755W002.

EMC TECHNOLOGY 8851 SW OLD KANSAS AVE. STUART, FL 34997	CAGE CODE # 24602		DWG #	1010355000
	CHANGE NOTICE	EN 08-E0534	REV LVL	A
			SHEET	1 OF 2

PART ID REF
CT2335S

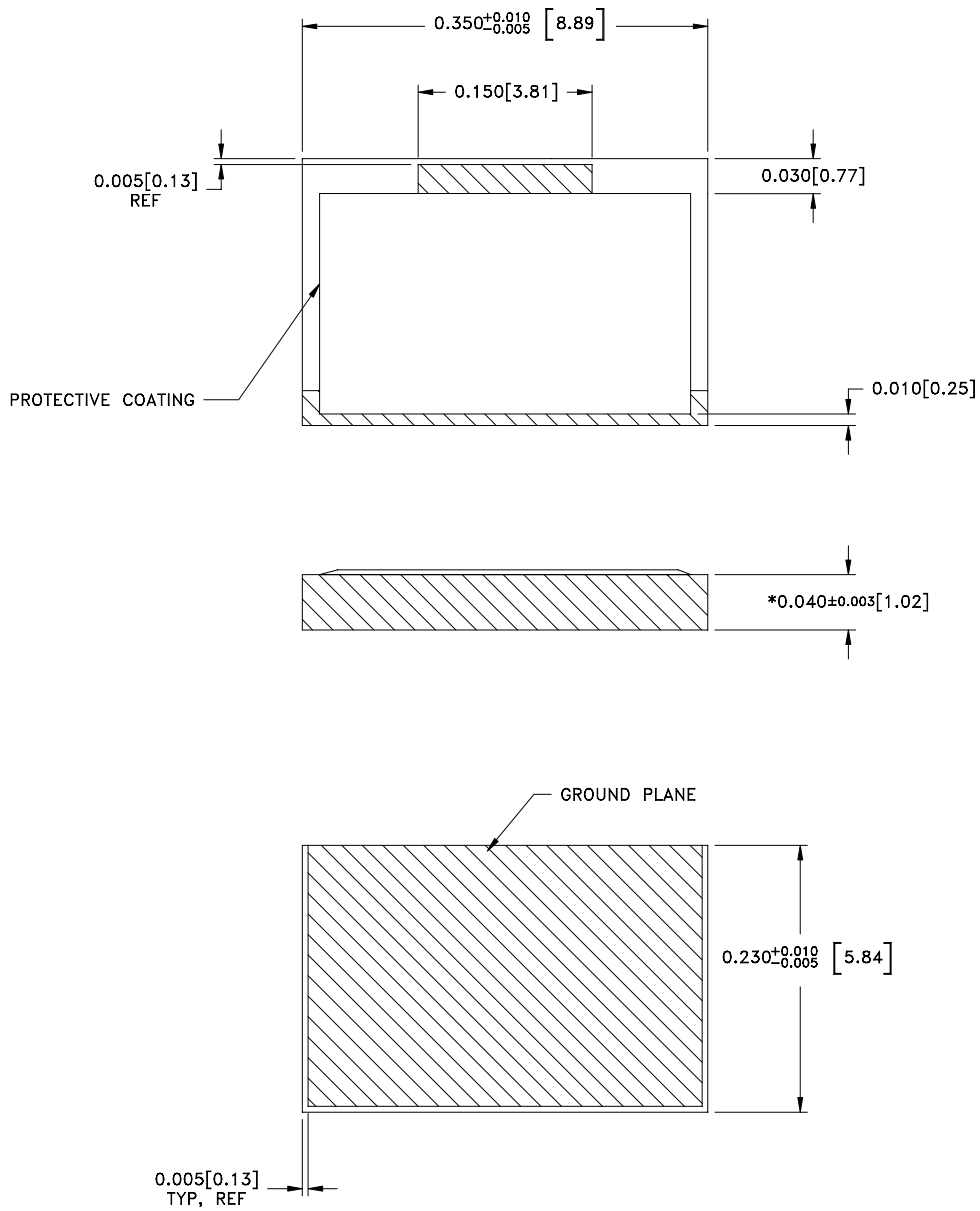

MECHANICAL SPECIFICATIONS:

SUBSTRATE:
MATERIAL - BERYLLIA, ASTM F356.
TERMINALS AND GROUND PLANE:
MATERIAL - THICK FILM, NICKEL BARRIER,
SOLDER COATED.
RESISTIVE ELEMENT:
MATERIAL - THICK FILM

METRIC EQUIVALENTS GIVEN IN [mm] ARE
FOR REFERENCE INFORMATION ONLY

* DIMENSION APPLY BEFORE SOLDER. ALLOW
0.015 MAX FOR ALL PRETINNED SURFACES.

EMC
Technology
8851 SW OLD KANSAS AVE
STUART, FL 34997
PHONE NO. (772)286-9300
FAX NO. (772)283-5286

UNLESS OTHERWISE
SPECIFIED DIMENSIONS
ARE IN INCHES
TOLERANCES
FRACT ---
ANG ---
XX ---
XXX ±0.005
XXXX ---

THESE DRAWINGS AND SPECIFICATIONS ARE THE PROPERTY OF EMC TECHNOLOGY INC AND SHALL NOT BE DUPLICATED
OR USED AS BASIS FOR THE MANUFACTURE OR SALE OF PARTS OR DEVICES WITHOUT PERMISSION.

CAGE CODE	SCALE	DRAWN BY	CHECKED BY	APPROVED BY
24602	1:1	JG 7/7/08		
REV	CHANGE NOTICE	DRAWING NO	SHEET	
A	EN 08-E0534	1010355000	2 OF 2	