

0.100" Centers

Standard Spring Probes

Board Test Fixture Probes & Receptacles



Board Test Spring Probes

Smiths Interconnect offers a wide range of spring contact probes to meet your testing requirements and has long been recognized as the world's largest probe manufacturer. With over 60 different probe series that includes our standard Board Test Fixture Probes as well as our Specialty Test Probes, we provide a full portfolio designed for general purpose test on bare boards, loaded printed circuit boards, surface mount assemblies and other forms of test.



MICRO SERIES PROBES

The Micro probe series range in pitch from 0.20" (0.51 mm) to 0.030" (0.76 mm) pitch and are typically between half an inch to an inch in length.

STANDARD PROBES

Our standard probes range in pitch from 0.039" (1.00 mm) to 0.187" (4.75 mm). Within most series, there are multiple length and travel options, including more aggressive probes dimensionally equivalent to the standard probes.

DOUBLE-ENDED PROBES & RECEPTACLES

Double-ended probes feature both a top-side and bottom-side compliant plunger. Double-ended receptacles are available with a permanent bottom-side plunger and a replaceable probe on the top side. They are also available with both a top and bottom-side replaceable probe.

LEAD FREE PROBES

The Lead Free probe series is based on our ICT Probe Series. The plunger material, plating and tip geometry have been optimized to provide less wear and contamination build-up while using a moderate spring force of 7 to 8 ounces.

ICT PROBES

The ICT probe design features a bifurcated barrel with four separate fingers. The barrel is compliant and formed against the plunger, thus eliminating any gap between the plunger and barrel. ICT probes are more accurate and stable in resistance than standard designs.

ROTATOR PROBES

Ideal for non-clean and lead-free applications, this aggressive probe rotates 90° at the rated travel, virtually drilling through contaminants with a low spring force.

HIGH CURRENT PROBES

We offer two different high current probe designs in four different pitches. The SH series features a bias ball, which is the most aggressive biasing technique to aid in assuring a low and consistent resistance, cycle after cycle. The SHE Series features a bias spring, an effective biasing technique for many applications.

SWITCH PROBES

A Switch Probe is a spring contact probe and receptacle that has two individual current paths. One current path is closed, the other is open and after a designated travel the second current path closes.

THERMOCOUPLE PROBES

The Thermocouple Probe is an ungrounded, thermally conductive probe used for the measurement of variations in temperature. We offer two Thermocouple Probes: Type T for up to 220°F, and Type K for up to 350°F.

COAXIAL PROBES

Our Coax Probes provide a low noise, controlled impedance signal path with reliable, easy connect/disconnect options. Our designs include a spring-loaded signal probe and a spring-loaded shielding plunger for the ground.

SS & GSS Series

0.100 (2.54) Centers

For RSS-100 Series Receptacles see pg. 8
 For R-100/SS Series Receptacles see pg. 9

For R-SS/SS Series Receptacles see pg. 10

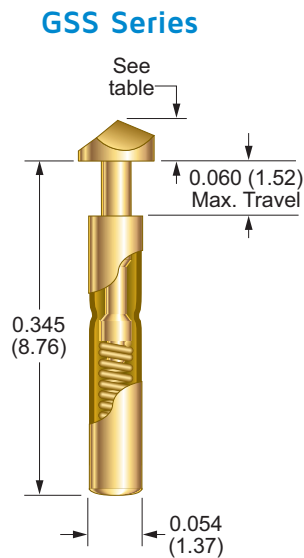
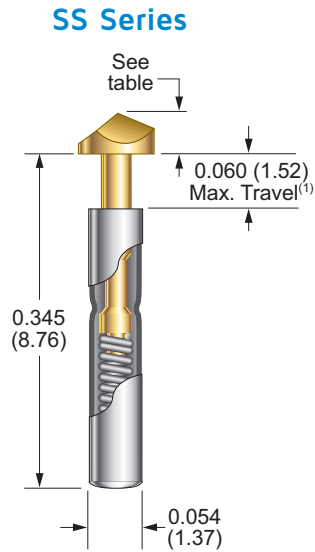

BeCu Tips Diameter

	37°	0.077 (1.96)	
	90°	0.077 (1.96)	
		0.077 (1.96)	
	37°	0.075 Radius	
	37°	0.062 (1.57)	
	60°	0.075 (1.91)	
		0.045 (1.14)	
	90°	0.045 (1.14)	
		0.075 (1.91)	
		0.045 (1.14)	

Probe Specifications

Minimum Centers	0.100 (2.54)
Current Rating	3 A continuous
Spring Force	3.80 oz (108 g) or 7.00 oz (198 g) @ 0.050 (1.27) travel
Preload Force	1.60 oz (45 g) (3.80 oz spring/stainless steel) 1.30 oz (37 g) (7.00 oz spring/music wire)
Typical Resistance	SS Series: < 65 mΩ GSS Series: < 30 mΩ
Maximum Travel	0.060 (1.52) ⁽¹⁾
Working Travel	0.050 (1.27)

Materials

Barrel	SS Series: Nickel/silver GSS Series: Nickel/silver, gold plated
Spring	SS Series: Stainless steel or music wire GSS Series: Stainless steel, or music wire, gold plated
Plunger	Beryllium copper, gold plated over nickel

1. Maximum travel for SS-8: 0.050 (1.27)

How to Order

SS - 1 - 3.8 - G
 1 2 3 4

1 Series	SS GSS
2 Tip Style	1, 2, 3, 4, 8, 10, 11, 18, 19
3 Spring Force	3.8 oz 7 oz
4 Plunger Plating	G Gold

TIP	HEAD LENGTH	TIP	HEAD LENGTH
1	0.040 (1.02)	10	0.028 (0.71)
2	0.028 (0.71)	11	0.040 (1.02)
3	0.028 (0.71)	18	0.060 (1.52)
4	0.040 (1.02)	19	0.055 (1.40)
8	0.080 (2.03)		

S-2 Series

0.100 (2.54) Centers

For R-2 Series Receptacles see pg. 11

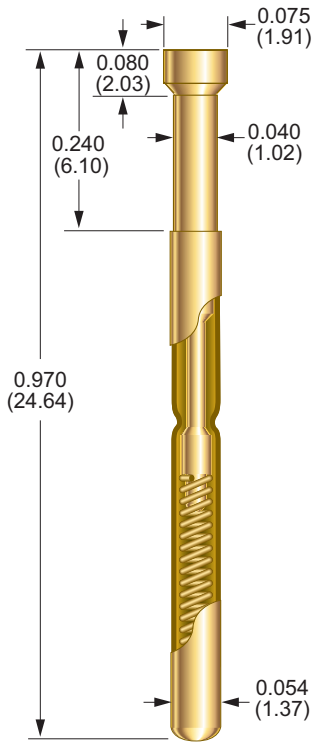

Becu Tips Diameter

Tip Style	Diameter
A 90°	0.075 (1.91)
B 30°	0.040 (1.02)
C	0.040 (1.02)
D	0.050 (1.27)
E 90°	0.075 (1.91)
F	0.075 (1.91)
G 90°	0.040 (1.02)
H	0.075 (1.91)
J	0.040 (1.02)
K 45°	0.075 (1.91)
T 60°	0.075 (1.91)
V	0.060 (1.52)
X	0.060 (1.52)

Probe Specifications

Minimum Centers	0.100 (2.54)
Current Rating	3 A continuous
Spring Force	4.00 oz (113 g), 7.00 oz (198 g), 8.30 oz (235 g), or 10.00 oz (283 g) @ 0.100 (2.54) travel
Preload Force	1.60 oz (45 g) (4.00 oz spring/BeCu) 2.90 oz (82 g) (7.00 oz spring/stainless steel) 3.30 oz (93 g) (8.30 oz spring/music wire) 3.90 oz (110 g) (10.00 oz spring/music wire)
Typical Resistance	< 35 mΩ
Maximum Travel	0.160 (4.06)
Working Travel	0.100 (2.54)

Materials

Barrel	Nickel/silver, gold plated
Spring	Beryllium copper, precious metal plated, music wire, or stainless steel, gold plated
Plunger	Beryllium copper, gold plated over nickel, or Duralloy™

How to Order

S - 2 - A - 4 - G
1 2 3 4 5

1 Series	S
2 Size	2
3 Tip Style	A, B, C, D, E, F, G, H, J, K, T, V, X,
4 Spring Force	4 oz 7 oz 8.3 oz 10 oz
5 Plunger Plating	G Gold D Duralloy™

ICT-100 & S-100 Series

0.100 (2.54) Centers

For R-100/SS Series Receptacles see pg. 9

For R-100 Series Receptacles see pg. 12

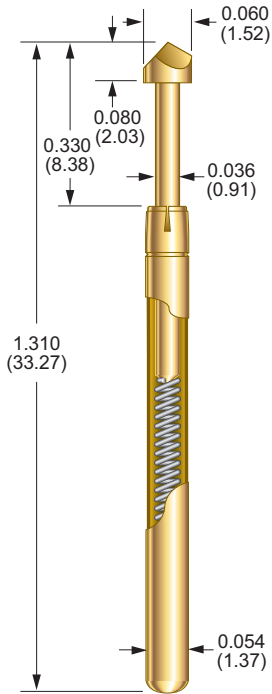

BeCu Tips Diameter

Tip Style	Diameter
A 90°	0.060 (1.52)
B 30°	0.036 (0.91)
D	0.050 (1.27)
F	0.060 (1.52)
H	0.060 (1.52)
HK	0.075 (1.91)
HL	0.093 (2.36)
HSC	0.068 (1.73) 0.075 (1.91) insulator dia.
J	0.036 (0.91)
JS 0.100 (2.54)	0.025 (0.64) 0.036 (0.91)
K 45°	0.060 (1.52)
T 60°	0.060 (1.52)
V8	0.060 (1.52) 8 Pts.

Probe Specifications

Minimum Centers	0.100 (2.54)
Current Rating	3 A continuous
Spring Force	3.50 oz (99 g) ⁽¹⁾ , 5.50 oz (156 g), 6.70 oz (190 g), 8.00 oz (227 g), 10.00 oz (283 g), or 17.00 oz (483 g) @ 0.170 (4.32) travel
Preload Force	1.50 oz (43 g) (3.50 ⁽¹⁾ oz spring/BeCu) 2.40 oz (68 g) (5.50 oz spring/music wire ⁽²⁾) 2.80 oz (80 g) (6.70 oz spring/stainless steel) 3.30 oz (94 g) (8.00 oz spring/music wire ⁽²⁾) 3.70 oz (105 g) (10.00 oz spring/music wire) 6.80 oz (193 g) (17.00 oz spring/music wire)
Typical Resistance	< 8 mΩ
Maximum Travel	0.250 (6.35)
Working Travel	0.170 (4.32)

Materials

Barrel	ICT Series: Gold lined S Series: Gold plated I.D. and O.D.
Spring	Beryllium copper or music wire, nickel plated, or stainless steel
Plunger	Beryllium copper, or steel, gold plated over nickel

How to Order

ICT - 100 - T - 5.5 - G - S
1 2 3 4 5 6

1 Series	ICT ⁽³⁾ S
2 Size	100
3 Tip Style	A, B, D, F, H, HK, HL, HSC, J, JS, K, NT, S, P, SWS, T, U, UR, V8, WO
4 Spring Force	3.5 oz ⁽¹⁾ 5.5 oz 6.7 oz 8 oz 10 oz 17 oz
5 Plunger Plating	G Gold
6 Steel Plunger Option	S Steel

- 3.50 oz. spring for S-100 Series only
- BeCu instead of music wire for S Series
- High performance

Steel Tips Diameter

B 30°	0.036 (0.91)
NT	0.055 (1.40)
SP 10°	0.036 (0.91)
SWS 20°	0.036 (0.91)
U 60°	0.036 (0.91)
UR	0.020 (0.51) 0.036 (0.91)
WO	0.050 (1.27)

S-100 Rotator Series

0.100 (2.54) Centers

For R-100 Series Receptacles see pg. 12

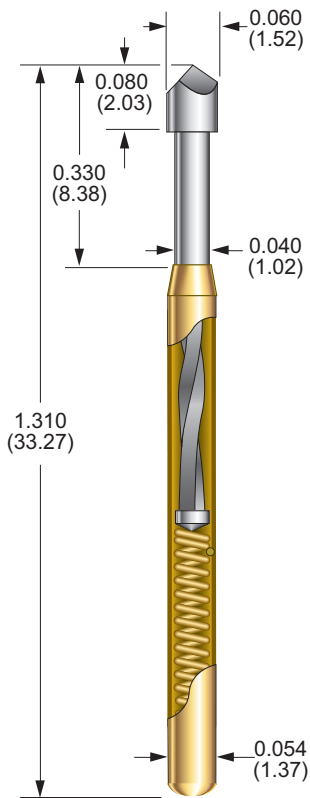

BeCu Tips Diameter

Tip Style	Tip Angle	Diameter
LM	90°	0.060 (1.52)
S	60°	0.040 (1.02)
T	60°	0.060 (1.52)

Probe Specifications

Minimum Centers	0.100 (2.54)
Current Rating	3 A continuous
Spring Force	4.00 oz (113 g), 5.50 oz (156 g), 6.70 oz (190 g), 8.00 oz (227 g), or 10.00 oz (283 g) @ 0.170 (4.32) travel
Preload Force	1.50 oz (43 g) (4.00 oz spring/stainless steel) 2.00 oz (57 g) (5.50 oz spring/stainless steel) 1.50 oz (43 g) (6.70 oz spring/stainless steel) 2.80 oz (80 g) (8.00 oz spring/music wire) 1.80 oz (51 g) (10.00 oz spring/music wire)
Typical Resistance	< 50 mΩ
Maximum Travel	0.220 (5.59)
Working Travel	0.170 (4.32)
Rotation	90° @ 0.170 (4.32) travel

Materials

Barrel	G2
Spring	Music wire, or stainless steel, gold plated
Plunger	Beryllium copper, Duralloy™ plated

How to Order

S - 100 - T - 4 - RT
1 2 3 4 5

1 Series	S
2 Size	100
3 Tip Style	LM, S, T
4 Spring Force	4 oz 5.5 oz 6.7 oz
	8 oz 10 oz
5 Rotator	RT

ICT-L100 Series

0.100 (2.54) Centers

For R-100/SS Series Receptacles see pg. 9

For R-100 Series Receptacles see pg. 12

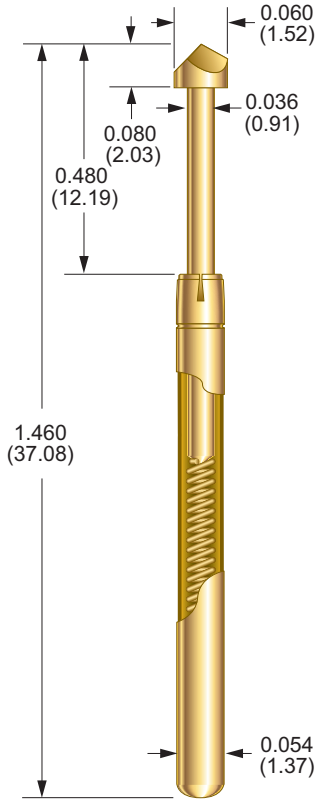

Becu Tips Diameter

<p>A</p>	<p>90°</p> <p>0.060 (1.52)</p>
<p>H</p>	<p>0.060 (1.52)</p>
<p>J</p>	<p>0.036 (0.91)</p>

Steel Tip Diameter

<p>SP</p>	<p>10°</p> <p>0.036 (0.91)</p>
------------------	--------------------------------

Probe Specifications

Minimum Centers	0.100 (2.54)
Current Rating	3 A continuous
Spring Force	5.70 oz (162 g) @ 0.317 (8.05) travel
Preload Force	1.80 oz (51 g)
Typical Resistance	< 10 mΩ
Maximum Travel	0.400 (10.16)
Working Travel	0.317 (8.05)

Materials

Barrel	G2
Spring	Music wire, gold plated over nickel
Plunger	Beryllium copper, or steel, gold plated over nickel

How to Order

ICT - L100 - J - 5.7 - G - S
 1 2 3 4 5 6

1 Series	ICT
2 Size	L100
3 Tip Style	A, H, J, SP
4 Spring Force	5.7 oz
5 Plunger Plating	G Gold
6 Steel Plunger Option	S Steel

RSS-100 Series

0.100 (2.54) Centers

For SS/GSS Series Probes see pg. 3

Part Number	Style/Termination	Receptacle or Terminal Length	Probe/Receptacle Combined Length	Notes
RSS-100-CR	Crimp	0.475 (12.07)	0.550 (13.97) ⁽¹⁾	—
RSS-100-NT	No Tail	0.402 (10.21)	0.462 (11.73) ⁽¹⁾	—
RSS-100-RP	Round Post	0.625 (15.88)	0.685 (17.40) ⁽¹⁾	0.220 post length – 0.028 dia.
RSS-100-WW	Wire Wrap	0.822 (20.88)	0.882 (22.40) ⁽¹⁾	0.420 post length – 0.025 dia.
RSS-100-PW-12-1	Preattached Wire ⁽²⁾	0.475 (12.07)	0.550 (13.97) ⁽¹⁾	12" wire length, 1" strip length
RSS-100-PW-36-1	Preattached Wire ⁽²⁾	0.475 (12.07)	0.550 (13.97) ⁽¹⁾	36" wire length, 1" strip length

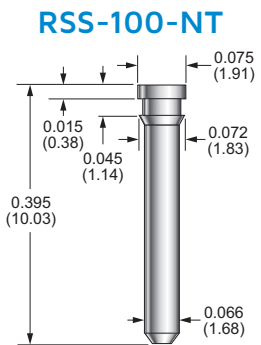
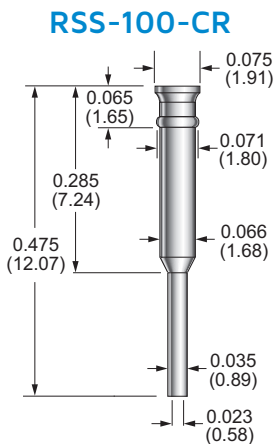

Probe Extension

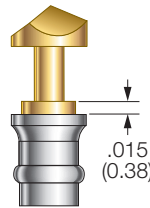

See chart for head length

TIP	HEAD LENGTH	TIP	HEAD LENGTH
1	0.040 (1.02)	10	0.028 (0.71)
2	0.028 (0.71)	11	0.040 (1.02)
3	0.028 (0.71)	18	0.060 (1.52)
4	0.040 (1.02)	19	0.055 (1.40)
5	0.080 (2.03)		

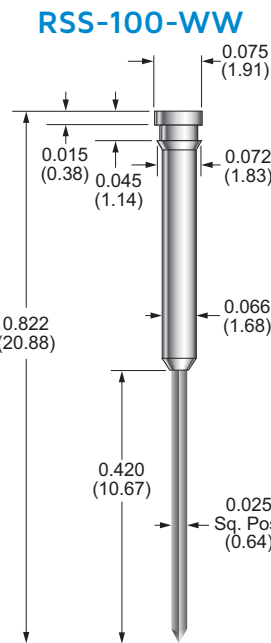
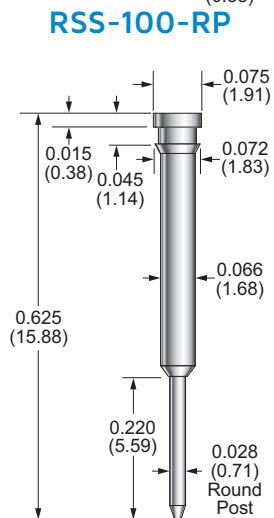

Probe Specifications

Minimum Centers	0.100 (2.54)
Drill Size	#50
Mounting Hole Size	0.068/0.070 (1.73/1.78)
Recommended Wire	28-30 gage
Materials	Nickel/silver

Tools

Crimping Pliers	CP-SS-100 (for 28-30 gage solid conductor)
Insertion Tool	RT-SS-100

How to Order

RSS - 100 - WW - G
1 2 3 4

1 Series	RSS
2 Size	100
3 Termination	CR Crimp NT No tail RP Round post WW Wire wrap PW - 12 - 1 Preattached wire 12", 1" strip length ⁽¹⁾ PW - 36 - 1 Preattached wire 36", 1" strip length ⁽¹⁾
4 Plating Options	G Gold

- Plus head length per tip style – see chart
- Wire length 36" with a 1" strip length, 12" & 36" standard, blue solid conductor Kynar wire

R-100/SS Series

0.100 (2.54) Centers

For ICT-L100 Series Probes see pg. 7 (for top end of receptacle)
 For SS/GSS Series Probes see pg. 3 (for bottom end of receptacle)

For ICT-100/S-100 Series Probes see pg. 5 (for top end of receptacle)

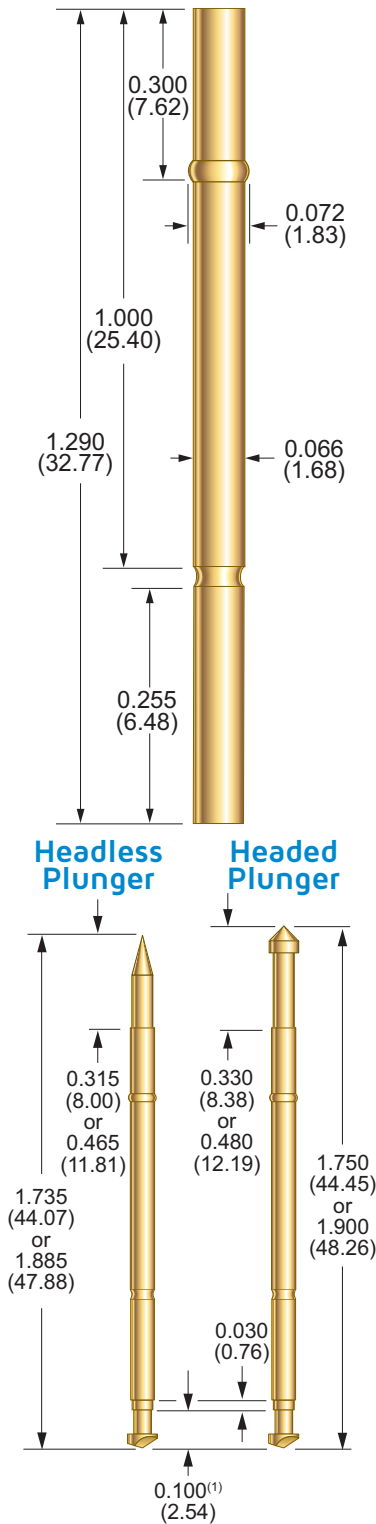

Probe Specifications

Minimum Centers	0.100 (2.54)
Drill Size	#50
Mounting Hole Size	0.068/0.070 (1.73/1.78)
Materials	Nickel/silver, gold plated

Tools

Insertion Tool	RT-100
----------------	--------

How to Order

R - 100 / S S
 1

1 Series	R - 100 / S S
----------	---------------

1. For plunger with 0.040 (1.02) tip length

R-SS/SS Series

0.100 (2.54) Centers

For SS/GSS Series Probes see pg. 3
(Receptacle houses an SS-100 or GSS-100 on each end)

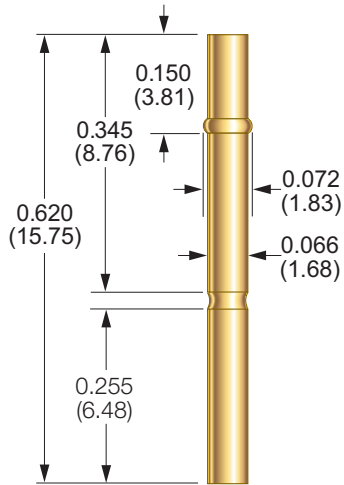

Headed Plunger

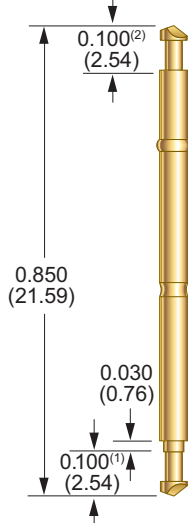

Probe Specifications

Minimum Centers	0.100 (2.54)
Drill Size	#50
Mounting Hole Size	0.068/0.070 (1.73/1.78)
Materials	Nickel/silver, gold plated

Tools

Insertion Tool	RT-100
----------------	--------

How to Order

R - S S / S S
1

1 Series

R - S S / S S

1. For plunger with 0.040 (1.02) tip length
2. Headed plunger only this end

R-2 Series

0.100 (2.54) Centers

For S-2 Series Probes see pg. 4

Part Number	Style/Termination	Receptacle or Terminal Length	Probe/Receptacle Combined Length	Notes
R-2-CR	Crimp	0.930 (23.62)	1.170 (29.72)	—
R-2-SC	Solder Cup	0.930 (23.62)	1.170 (29.72)	—
R-2-RP	Round Post	1.305 (31.15)	1.545 (39.24)	0.375 post length – 0.025 dia.
R-2-WW-429	Wire Wrap	1.359 (34.52)	1.599 (40.61)	0.429 post length – 0.025 dia.

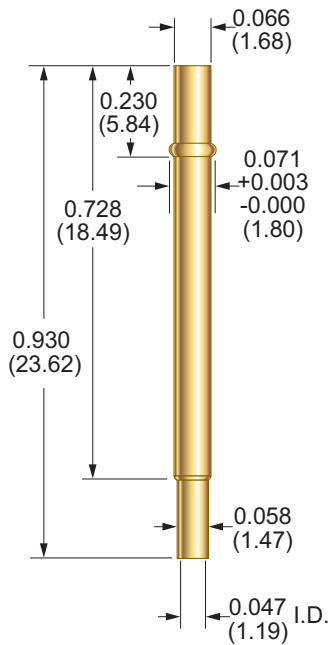

Probe Specifications

Minimum Centers	0.100 (2.54)
Drill Size	#50
Mounting Hole Size	0.068/0.070 (1.73/1.78)
Recommended Wire	22-26 gage
Materials	Nickel/silver, gold plated, gold plated post

Tools

Crimping Pliers	CP-2 (for 22-26 gage solid conductor)
Insertion Tool	RT-100

How to Order

R - 2 - WW - 4 2 9
 1 2 3

1 Series	R
2 Size	2
3 Termination	CR Crimp SC Solder Cup
	RP Round Post
	WW - 4 2 9 Wire wrap 0.429 post length

R-100 Series

0.100 (2.54) Centers

For ICT-100/S-100 Series Probes see pg. 5
For S-100 Rotator Series Probes see pg. 6

For ICT-L100 Series Probes see pg. 7

Part Number	Style/Termination	Receptacle or Terminal Length	Probe/Receptacle Combined Length		Notes
			ICT-100/S-100	ICT-L100	
R-100-CR	Crimp	1.165 (29.59)	1.495 (37.97)	1.645 (41.78)	—
R-100-SC	Solder Cup	1.165 (29.59)	1.495 (37.97)	1.645 (41.78)	—
R-100-RP	Round Post	1.540 (39.12)	1.870 (47.50)	2.020 (51.31)	0.375 post length – 0.025 dia.
R-100-WW-429	Wire Wrap	1.594 (40.49)	1.924 (48.87)	2.074 (52.68)	0.429 post length – 0.025 dia.

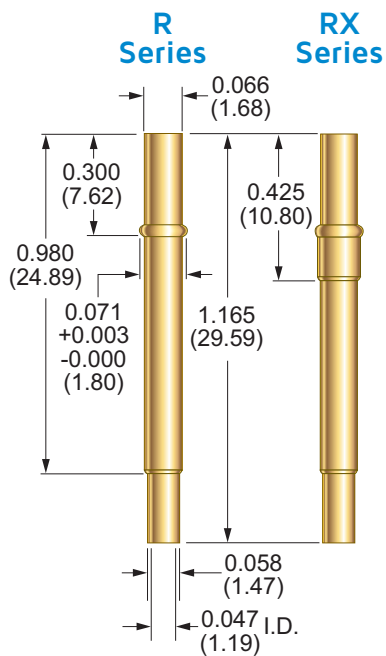

Probe Specifications

Minimum Centers	0.100 (2.54)
Drill Size	#50
Mounting Hole Size	0.068/0.070 (1.73/1.78)
Recommended Wire	22-26 gage
Materials	Nickel/silver, gold plated, gold plated post

Tools

Crimping Pliers	CP-2 (for 22-26 gage solid conductor)
Insertion Tool	RT-100

How to Order

R - 100 - WW - 429
1 2 3

1 Series	R	R X ⁽¹⁾
2 Size	100	
3 Termination	CR Crimp	SC Solder Cup
	RP Round Post	
	WW - 429	Wire wrap 0.429 post length

Worldwide Support

Connectors

Americas

Sales

connectors.uscsr@smithsinterconnect.com

Technical Support

connectors.ustechsupport@smithsinterconnect.com

Europe

Sales

connectors.emeacsr@smithsinterconnect.com

Technical Support

connectors.emeatechsupport@smithsinterconnect.com

Asia

Sales

asiacsr@smithsinterconnect.com

Technical Support

asiatechsupport@smithsinterconnect.com

Fiber Optics & RF Components

Americas

Sales

focom.uscsr@smithsinterconnect.com

Technical Support

focom.techsupport@smithsinterconnect.com

Europe

Sales

focom.emeacsr@smithsinterconnect.com

Technical Support

focom.techsupport@smithsinterconnect.com

Asia

Sales

focom.asiacsr@smithsinterconnect.com

Technical Support

focom.techsupport@smithsinterconnect.com

Semiconductor Test

Americas

Sales

semi.uscsr@smithsinterconnect.com

Technical Support

semi.techsupport@smithsinterconnect.com

Europe

Sales

semi.emeacsr@smithsinterconnect.com

Technical Support

semi.techsupport@smithsinterconnect.com

Asia

Sales

semi.asiacsr@smithsinterconnect.com

Technical Support

semi.techsupport@smithsinterconnect.com

RF/MW Subsystems

Americas, Europe & Asia

Sales

subsystems.csr@smithsinterconnect.com

Technical Support

subsystems.techsupport@smithsinterconnect.com

Connecting Global Markets

smithsinterconnect.com |    

Copyright© 2024 Smiths Interconnect | All rights reserved | Version 1.1

The information contained within this document is subject at all times to applicable Export Control regulations and legal requirements.