

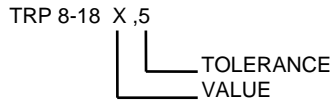

**TITLE: SPECIFICATION CONTROL DRAWING**

**PART IDENTIFIER:**



**DESCRIPTION:** : ROD RESISTOR, BERYLLIA

**ASSEMBLY DWG:** 1300014

**1.0 SPECIFICATIONS:**

- 1.1 ELECTRICAL:
  - 1.1.1 RESISTANCE RANGE: 10Ω TO 250Ω.
  - 1.1.2 TOLERANCE: 5%.
  - 1.1.3 INPUT POWER:
    - 1.1.3.1 IN AIR 125°C: 0.25 WATT.
    - 1.1.3.2 HEAT SINK 100°C: 20 WATTS.
- 1.2 MECHANICAL:
  - 1.2.1 OUTLINE DWG: SEE SHEET 2.
  - 1.2.2 WORKMANSHIP: PER MIL-STD-454, REQUIREMENT 9.
- 1.3 ENVIRONMENTAL:
  - 1.3.1 TEMPERATURE RANGE:
    - 1.3.1.1 NON-OPERATING: -55° C TO +150° C.
    - 1.3.1.2 OPERATING: -55°C TO +125°C.

**2.0 UNIT MARKING:** NONE

**3.0 QUALITY ASSURANCE:**

- 3.1 VISUAL INSPECTION:
  - 3.1.1 SAMPLE INSPECT PER ANSI/ASQC Z1.4 GENERAL INSPECTION, LEVEL II, AQL = 1.0.
  - 3.1.2 VISUAL AND MECHANICAL EXAMINATION FOR CONFORMANCE TO CONTROL DRAWING REQUIREMENTS.
- 3.2 100% DCR CHECK:
  - 3.2.1 ACCEPTANCE LIMITS: RESISTANCE VALUES AND TOLERANCE AS SPECIFIED ON PART ROUTING.
- 3.3 SAMPLE DCR CHECK. 5% TOLERANCE ONLY.
  - 3.3.1 SAMPLE INSPECT PER ANSI/ASQC Z1.4 GENERAL INSPECTION, LEVEL II, AQL = 1.0.
  - 3.3.2 ACCEPTANCE LIMITS: RESISTANCE VALUES AND TOLERANCE AS SPECIFIED ON PART ROUTING.

**4.0 PACKAGING:** STANDARD PACKING PER 755W002.

<b>EMC TECHNOLOGY</b> <b>8851 SW OLD KANSAS AVE.</b> <b>STUART, FL 34997</b>	<b>CAGE CODE # 24602</b>		<b>DWG #</b>	1001615000
	<b>CHANGE NOTICE</b>	EN 13-2976	<b>REV LVL</b>	E
			<b>SHEET</b>	1 OF 2

PART ID REF

TRP 8-18

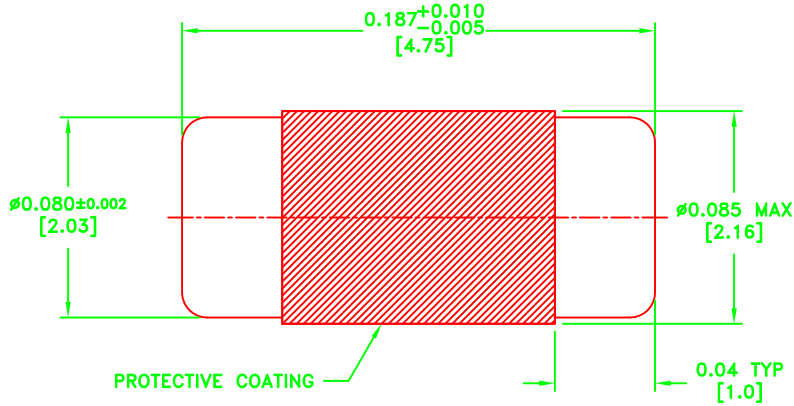

**MECHANICAL SPECIFICATIONS:**

**SUBSTRATE:**  
**MATERIAL - BERYLLIA 99.5%, ASTM F356.**  
**TERMINAL:**  
**MATERIAL - GOLD OVER NICKEL PLATING.**

METRIC EQUIVALENTS GIVEN IN [mm]  
FOR REFERENCE INFORMATION ONLY



8851 SW OLD KANSAS AVE  
 STUART, FL 34997  
 PHONE NO. (772) 286-9300  
 FAX NO. (772) 283-5286

UNLESS OTHERWISE  
 SPECIFIED DIMENSIONS  
 ARE IN INCHES

**TOLERANCES**

FRACT	---
ANG	---
XX	$\pm 0.01$
XXX	$\pm 0.005$
XXXX	---

THESE DRAWINGS AND SPECIFICATIONS ARE THE PROPERTY OF EMC TECHNOLOGY INC AND SHALL NOT BE DUPLICATED OR USED AS BASIS FOR THE MANUFACTURE OR SALE OF PARTS OR DEVICES WITHOUT PERMISSION.

CAGE CODE	SCALE	DRAWN BY	CHECKED BY	APPROVED BY
24602	1:1	CME 01/09/2002		DAR 1/9/02
REV	CHANGE NOTICE	DRAWING NO	SHEET	
E	EN 13-2976	1001615000	2 OF 2	