

KA Series

MIL-DTL-55302 Compliant PCB connectors

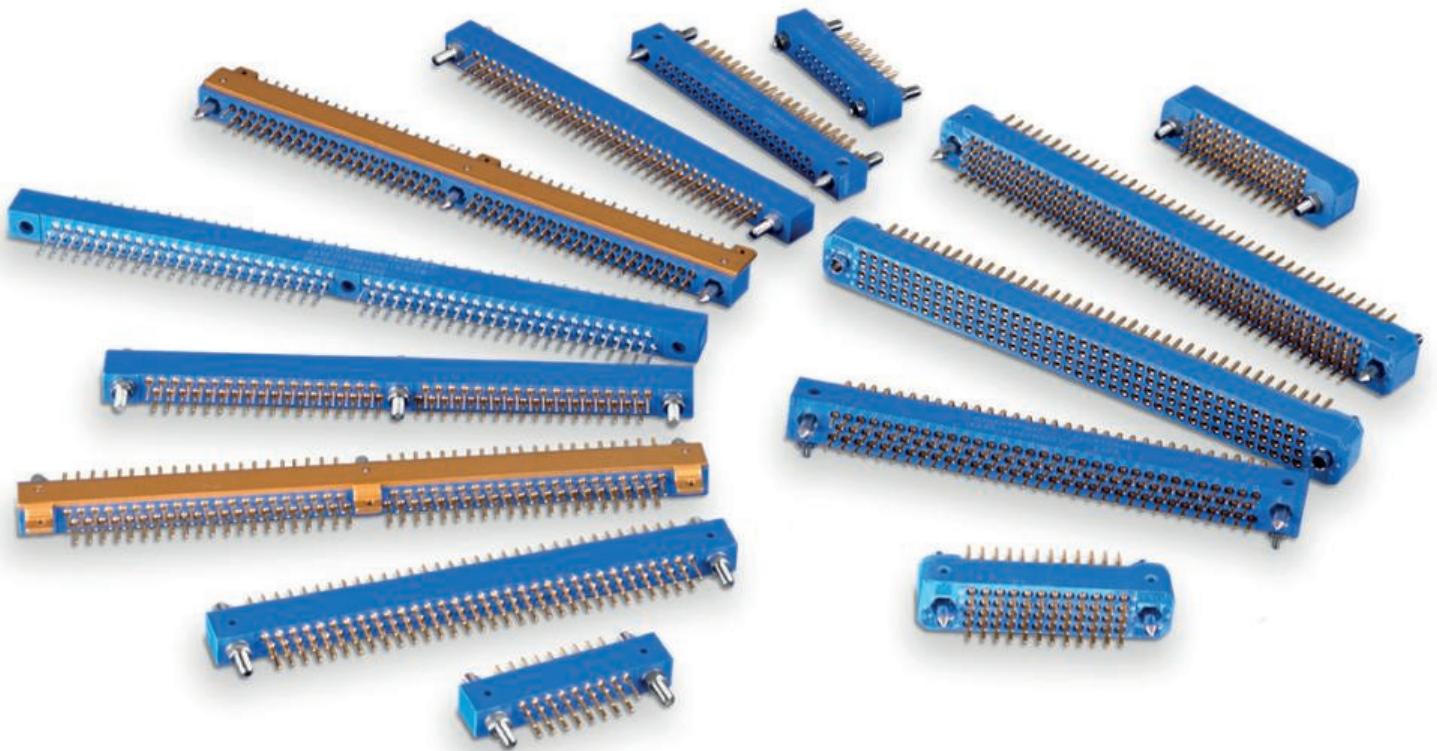

Hypertac® Hyperboloid Technology

Smiths Interconnect offers an extensive range of superior contact technologies suitable for standard and custom solutions. Hypertac® (HYPERboloid conTACT) is the original superior performing hyperboloid contact technology designed for use in all applications and in harsh and demanding environments where high reliability and safety are critical. The inherent electrical and mechanical characteristics of the Hypertac hyperboloid contact ensure unrivalled performance in terms of reliability, number of mating cycles, low contact force and minimal contact resistance. The shape of the contact sleeve is formed by hyperbolically arranged contact wires, which align themselves elastically as contact lines around the pin, providing a number of linear contact paths.

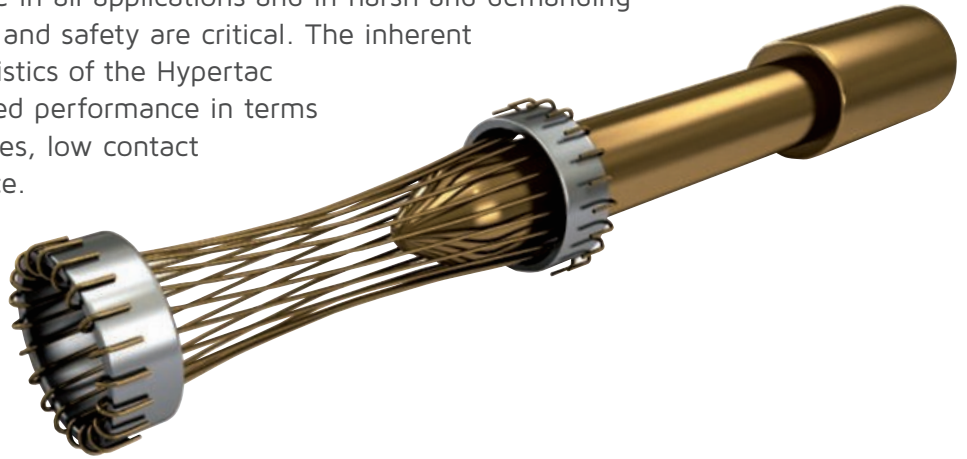

Features

Benefits

Low insertion/extraction forces

The angle of the socket wires allows tight control of the pin insertion and extraction forces. These spring wires are smoothly deflected to make line contact with the pin.

High density interconnect systems

Significant reductions in size and weight of sub-system designs. No additional hardware is required to overcome mating and un-mating forces.

Long contact life

The smooth and light wiping action minimizes wear on the contact surfaces. Contacts perform up to 100,000 insertion/extraction cycles with minimal degradation in performance.

Low cost of ownership

The Hypertac contact technology will surpass most product requirements, thus eliminating the burden and cost of having to replace the connector or the entire subsystem.

Lower contact resistance

The design provides a far greater contact area and the wiping action of the wires insures a clean and polished contact surface. Our contact technology has about half the resistance of conventional contact designs.

Low power consumption

The lower contact resistance of our technology results in a lower voltage drop across the connector reducing the power consumption and heat generation within the system.

Higher current ratings

The design parameters of the contact (e.g., the number, diameter and angle of the wires) may be modified for any requirement. The number of wires can be increased so the contact area is distributed over a larger surface. Thus, the high current carried by each wire because of its intimate line contact, can be multiplied many times.

Maximum contact performance

The lower contact resistance of the Hypertac contact reduces heat build-up; therefore Hypertac contacts are able to handle far greater current in smaller contact assemblies without the detrimental effects of high temperature.

Immunity to shock & vibration

The low mass and resultant low inertia of the wires enable them to follow the most abrupt or extreme excursions of the pin without loss of contact. The contact area extends 360° around the pin and is uniform over its entire length. The 3 dimensional symmetry of the Hypertac contact design guarantees electrical continuity in all circumstances.

Reliability under harsh environments

Harsh environmental conditions require connectors that will sustain their electrical integrity even under the most demanding conditions such as shock and vibration. The Hypertac contact provides unmatched stability in demanding environments when failure is not an option.

Contents

KA Series

Technical Characteristics	3
Current Derating Curves	4
Dimensions:	
2 & 3 Row Connectors	5
4 Row Connectors	8
5 Row Connectors	10
Terminal Styles:	
Style B.....	12
Style C.....	13
Style D/DD/FD.....	14
Style H2.....	15
Style R.....	15
Style S.....	16
Style W.....	16
Style Y.....	17
Replacement Contacts.....	18
Standard Mounting Hardware.....	19
Locking Hardware	24
Board Mounting Applications & Dimensions	29
Panel Cutouts:	
2 & 3 Row Connectors	34
4 & 5 Row Connectors	36
Accessories.....	37
How to Order.....	38
Military Part Number Cross Reference.....	39

KA Series

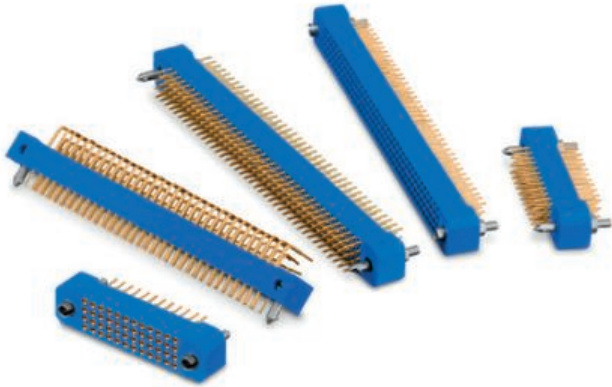

The KA Series connector family is part of Smiths Interconnect's portfolio of interconnect solutions designed and developed for rugged applications in the military, aerospace and commercial aviation markets. The KA Series is a highly engineered connector family that has gained a reputation for reliability under all varieties of extreme environmental conditions.

Utilizing the field-proven capabilities of the Hypertac® hyperboloid contact technology, the KA Series provides immunity to detrimental fretting due to shock and vibration, industry leading mating cycles and durability in a connector that meets the performance requirements of MIL-DTL-55302. With more than 2,500 configurations, the KA Series provides design flexibility not available with other MIL-DTL-55302 connectors. Additionally, the KA Series supports a current rating of up to 9 Amps per contact, low contact resistance and minimal insertion and extraction forces.

The technological innovation that Smiths Interconnect has designed into the KA Series enables it to provide a significant edge in demanding military, aerospace and commercial aviation operating environments where performance and reliability is essential.

**High reliability
PCB connectors
for demanding
applications**

Features & Benefits

Meets performance requirements of MIL-DTL-55302

Design flexibility

- Ruggedized connector with straight through-hole solder, right angle PCB solder, crimp, solder cup, and Wire-Wrap® termination options
- Offered in 2 to 5 row configurations with pin counts from 17 to 490 contacts
- End guides provide alignment and 36 user-changeable keying combinations
- Male and female contacts and guides available in either plug or receptacle

0.024 [0.60mm] diameter contacts rated at 4 Amps nominal, individual contacts are rated at up to 9 Amps (see technical characteristics).

Pitch of 0.100 [2.54] on center

- Adjacent rows offset by 0.05 [1.27] to allow straight printed circuit traces in 2 & 3 row connectors only

Average insertion/extraction force of 1 oz. per contact

Contacts removable from wiring side

- Front release, rear removable
- Front removable option available only on select contact configurations

Technical Characteristics

2 & 3 Row

4 & 5 Row

Number of Contacts	17, 29, 33, 41, 53, 62, 65, 72, 80, 84, 96, 98, 120, 126, 160	48, 68, 80, 96, 100, 108, 120, 125, 128, 136, 140, 160, 184, 196, 200, 208, 228, 230, 240, 264, 300, 320, 330, 352, 390, 392, 490
Pitch	0.100 [2.54]	
Contact Termination	Straight dip, right angle solder, crimp, solder cup and Wire Wrap® available	
Contact Diameter	0.024 [0.60]	

Mechanical & Environmental

Temperature Rating	-55° to 125°C
Shock	Shock testing to MIL-DTL-55302 para 4.5.14, and ESCC 3401 para 9.12
Vibration	Vibration testing to MIL-DTL-55302 para 4.5.10, and ESCC 3401 para 9.11
Contact Life Cycles	100,000
Extraction Force	0.30 to 2.00 oz. per contact

Material & Finishes

Insulator	Diallyl-phthalate
Contact	Beryllium copper wires and brass body
Contact Plating	Gold over nickel (tin-lead on PCB termination available)
Guide Hardware	Brass/stainless steel
Guide Hardware Plating	Nickel/passivated stainless steel

Electrical

Current Rating(*)	4 A at 30°C rise, nominal (**) <ul style="list-style-type: none"> ■ 9 A at 30°C rise, single contact ■ 6.5 A at 30°C rise, 2 adjacent contacts ■ 5.4 A at 30°C rise, 4 adjacent contacts 	
Contact Resistance	< 5 mΩ	
Insulation Resistance	> 5 GΩ at 500 VDC	
DWV	1200 V RMS	1050 V RMS
Breakdown Voltage Between Contacts	1600 V RMS	1400 V RMS

(*) For details, please contact Smiths Interconnect

(**) See Current Derating Curves on page 4

Notes:

1) Wire Wrap is a trademark of Gardner Denver.

Dimensions are in inches [mm] | All content is subject to change without notice

Current Derating Curves

Current Capacity Test - Single Pin

Max T-Rise (C) vs. Current (A)
KA100 = 1Pin Series

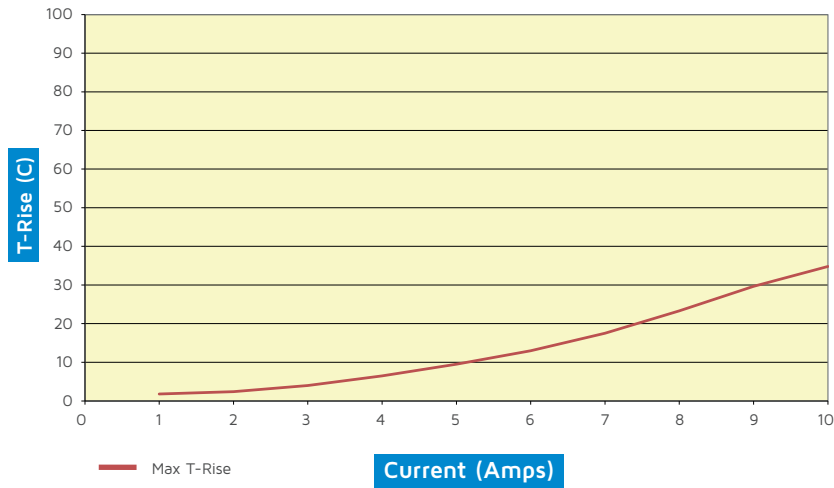

Current Capacity Test - 2 Pin Series

Max T-Rise (C) vs. Current (A)
KA100 = 2 Pin Series

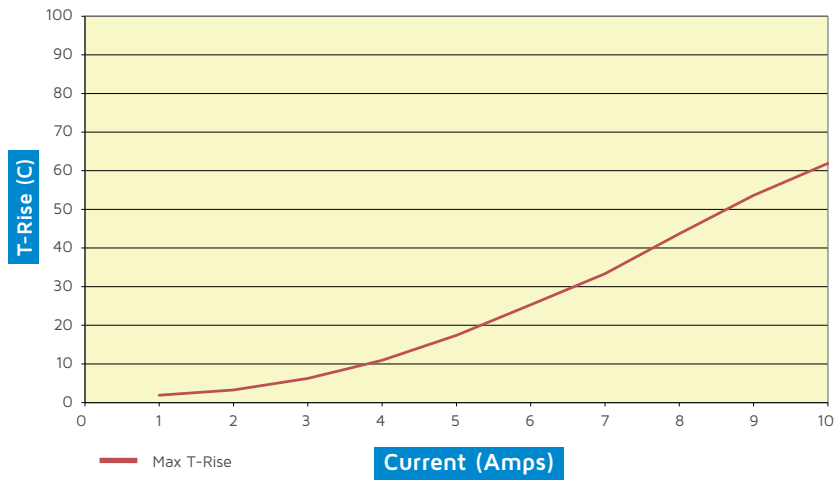

Current Capacity Test - 4 Pin Series

Max T-Rise (C) vs. Current (A)
KA100 = 4 Pin Series

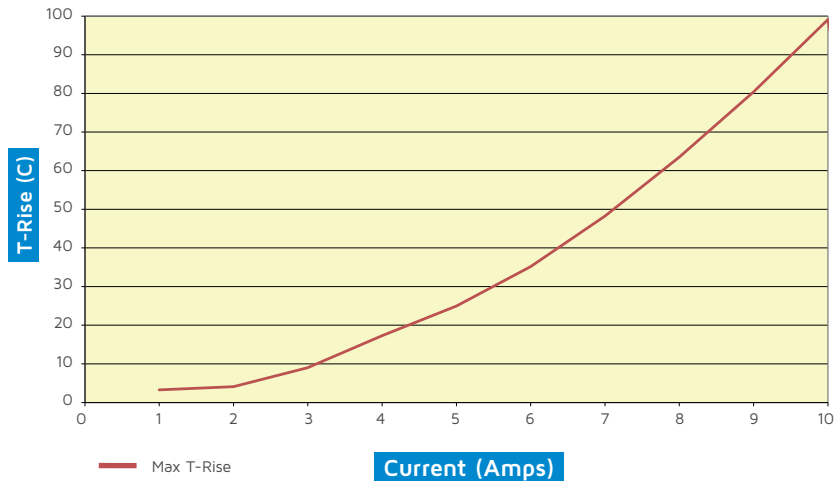

Dimensions *2 to 5 Row Connectors, 17 to 490 Contacts*

2 Row Connectors

17 to 65 Contacts

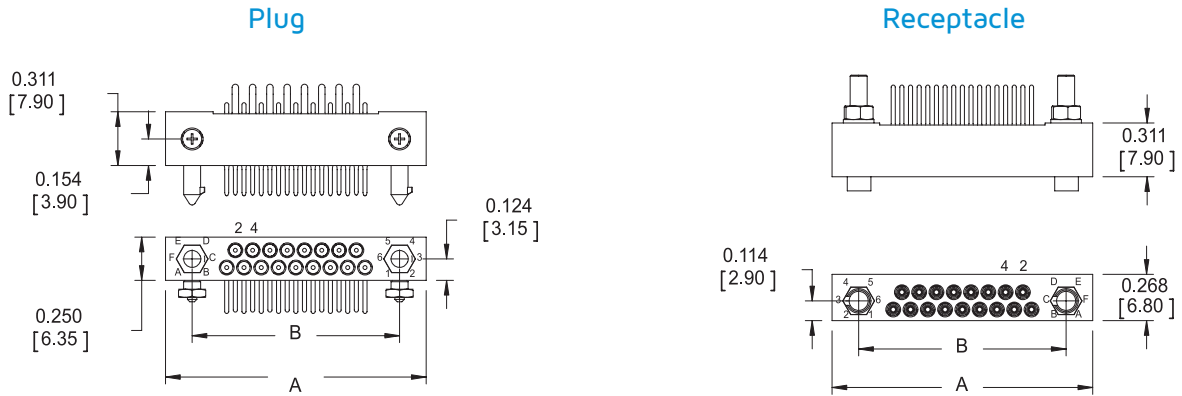

Contacts	A ±0.020 [0.50]	B	Mated pair
17	1.508 [38.30]	1.200 [30.48]	0.622 [15.80]
29	2.106 [53.54]	1.800 [45.72]	
33	2.308 [58.62]	2.000 [50.80]	
41	2.708 [68.78]	2.400 [60.96]	
53	3.308 [84.02]	3.000 [76.20]	
65	3.908 [99.26]	3.600 [91.44]	

3 Row Connectors

62, 80.1 & 98 Contacts

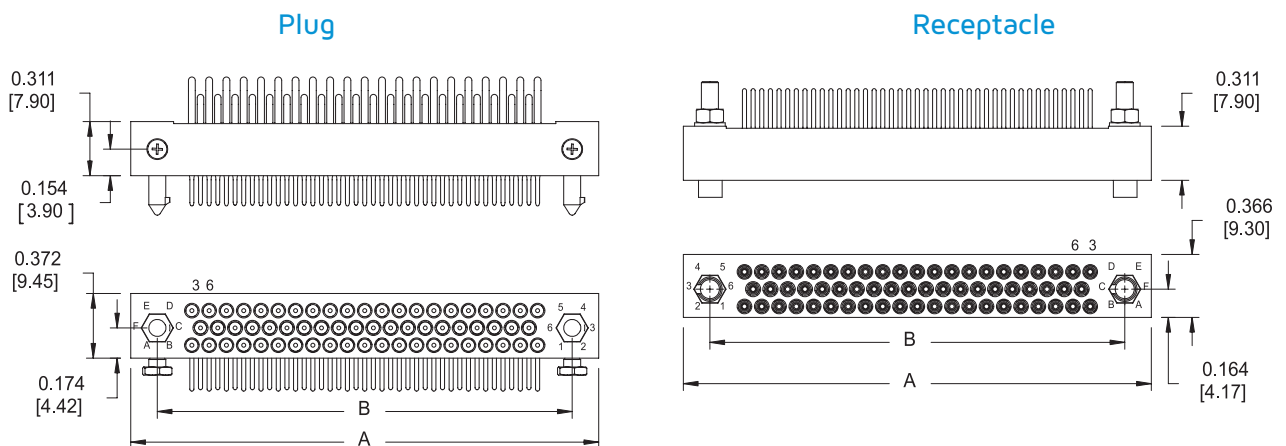

Contacts	A ±0.020 [0.50]	B	Mated pair
62	2.707 [68.75]	2.400 [60.96]	0.622 [15.80]
80.1	3.307 [84.00]	3.000 [76.20]	
98	3.907 [99.24]	3.600 [91.44]	

2 Row Connectors

72, 84, 96 & 120 Contacts

Plug

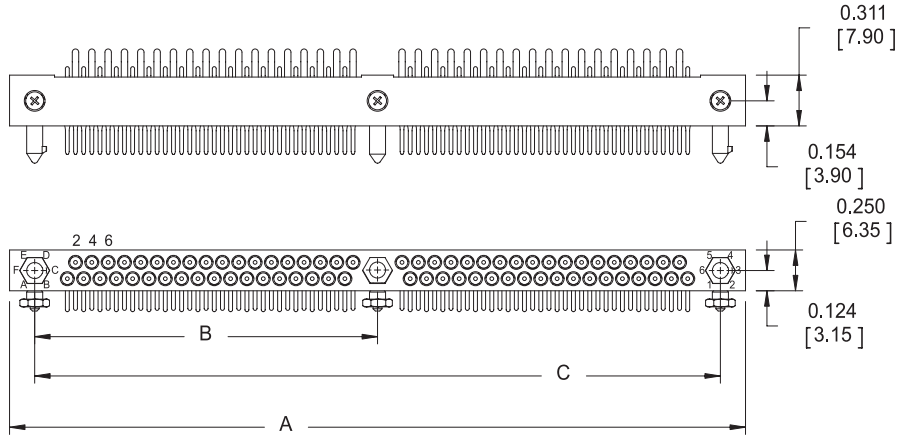

Receptacle

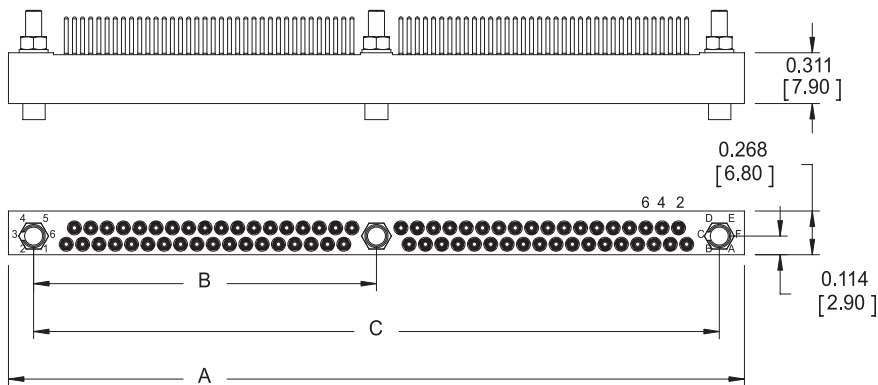

Contacts	A	B	C	Mated pair
72	4.508 [114.50]	2.100 [53.34]	4.200 [106.68]	0.622 [15.80]
84	5.108 [129.74]	2.400 [60.96]	4.800 [121.92]	
96	5.708 [144.98]	2.700 [68.58]	5.400 [137.16]	
120	6.908 [175.46]	3.300 [83.82]	6.600 [167.64]	

3 Row Connectors

126 Contacts

Plug

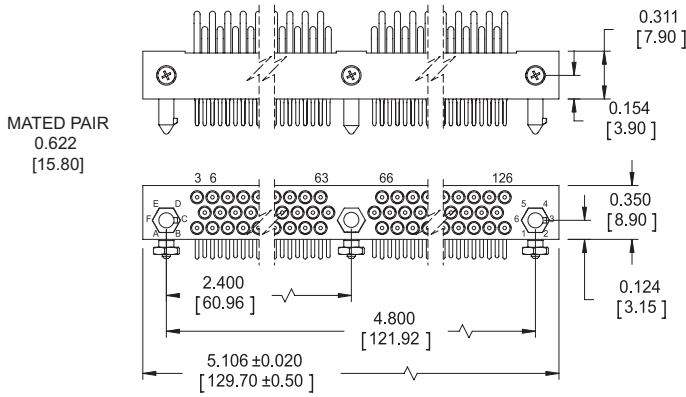

Receptacle

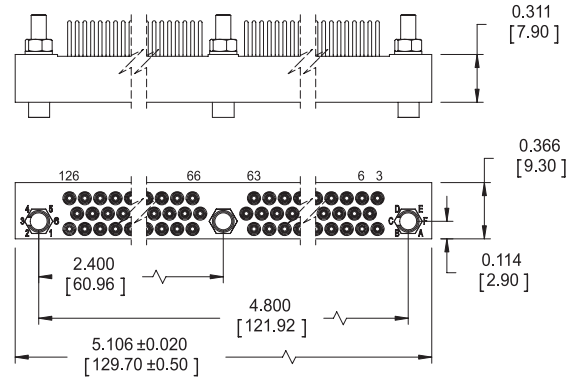

160 Contacts

Plug

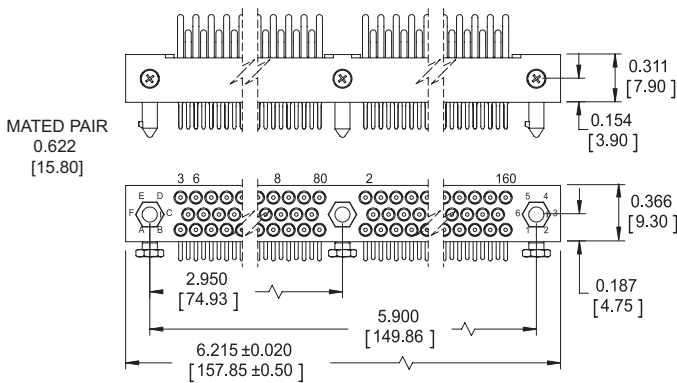

Receptacle

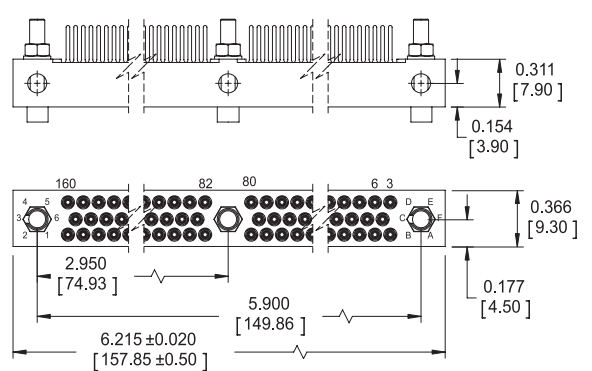

3 Row Connectors

160.4 Front Removable Contacts⁽¹⁾⁽²⁾

Receptacle

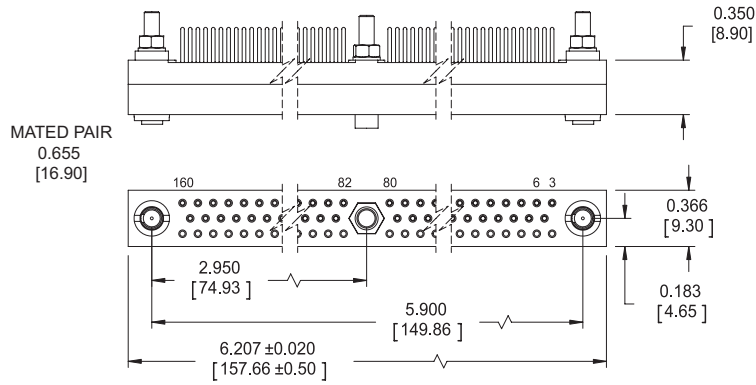

4 Row Connectors

48 to 228 Contacts

Plugs

Receptacles

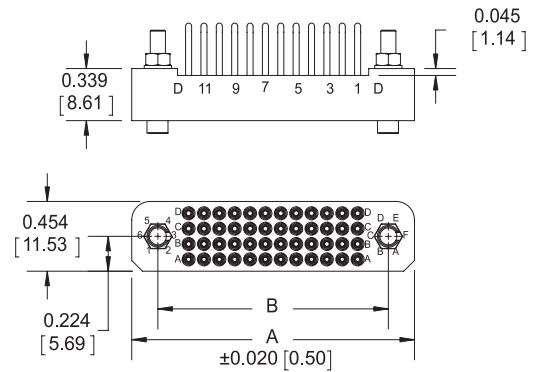
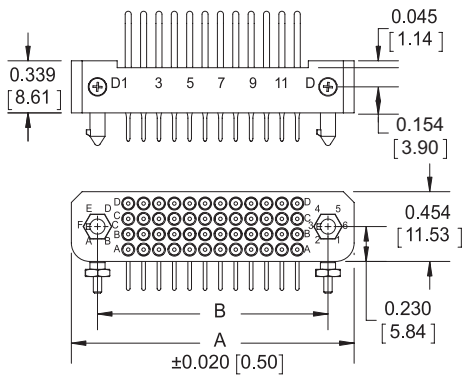

Contacts	A ±0.020 [0.50]	B	Mated pair 0.678 [17.22]
48	1.840 [46.74]	1.500 [38.10]	0.678 [17.22]
68	2.340 [59.44]	2.000 [50.80]	
80	2.640 [67.06]	2.300 [58.42]	
96	3.040 [77.22]	2.700 [68.58]	
100	3.140 [79.76]	2.800 [71.12]	
108	3.340 [84.84]	3.000 [76.20]	
120	3.640 [92.46]	3.300 [83.82]	
128	3.840 [97.54]	3.500 [88.90]	
136	4.040 [102.62]	3.700 [93.98]	
160	4.640 [117.86]	4.300 [109.22]	
184	5.240 [133.10]	4.900 [124.46]	
196	5.540 [140.72]	5.200 [132.08]	
228	6.340 [161.04]	6.000 [152.40]	

Notes:

- 1) Only available with straight dip solder (style "D") and Wire Wrap (style "Y") tails.
- 2) Mates with standard plug.

Dimensions are in inches [mm] | All content is subject to change without notice

4 Row Connectors

208, 240, 264, 352 & 392 Contacts

Plugs

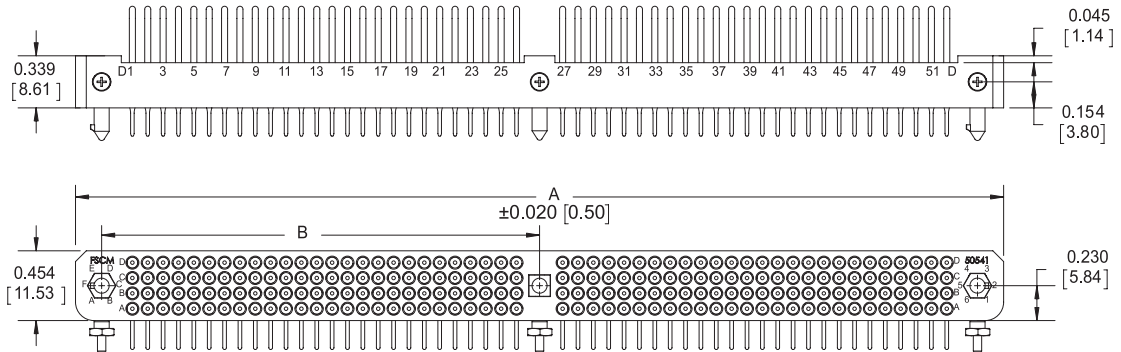

Receptacles

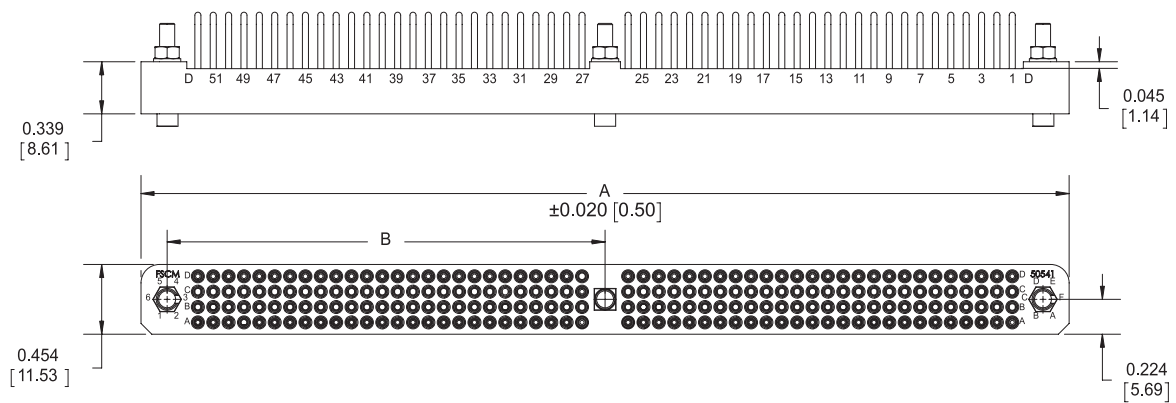

Contacts	A ±0.020 [0.50]	B	Mated pair
208	6.040 [153.42]	2.850 [72.39]	0.678 [17.22]
240	6.840 [173.74]	3.250 [82.55]	
264	7.438 [188.92]	3.550 [90.17]	
352	9.640 [244.86]	4.650 [118.11]	
392	10.640 [270.26]	5.150 [130.81]	

Notes:

1) For insulators longer than 7.00 [178.00], a mother board-daughter board configuration is highly recommended.

Dimensions are in inches [mm] | All content is subject to change without notice

5 Row Connectors

125, 140, 160, 200, 230 & 240 Contacts

Plugs

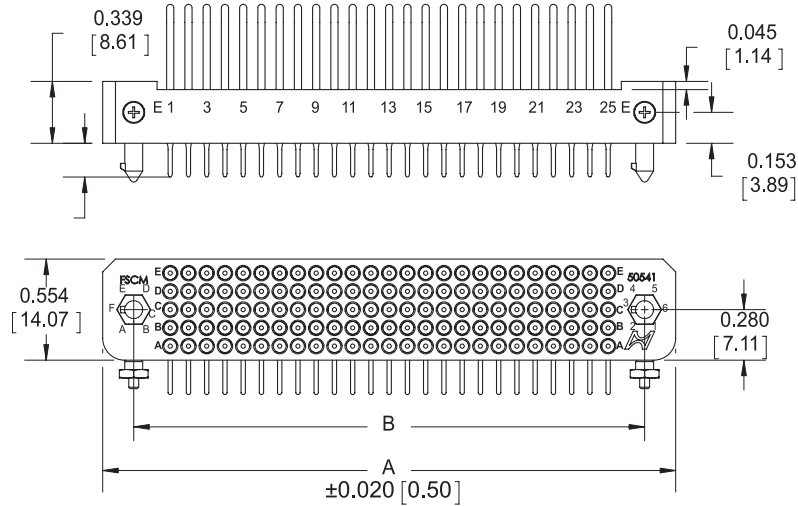

Receptacles

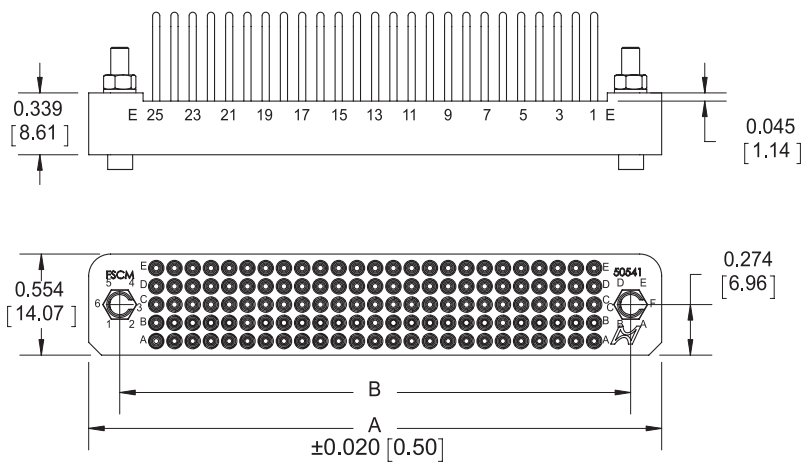

Contacts	A ±0.020 [0.50]	B	Mated pair
125	3.140 [79.76]	2.800 [71.12]	0.678 [17.22]
140	3.440 [87.38]	3.100 [78.74]	
160	3.840 [97.54]	3.500 [88.92]	
200	4.640 [117.86]	4.300 [109.22]	
230	5.240 [133.10]	4.900 [124.46]	
240	5.440 [138.10]	5.100 [129.54]	

5 Row Connectors

300, 320, 330, 390 & 490 Contacts

Plugs

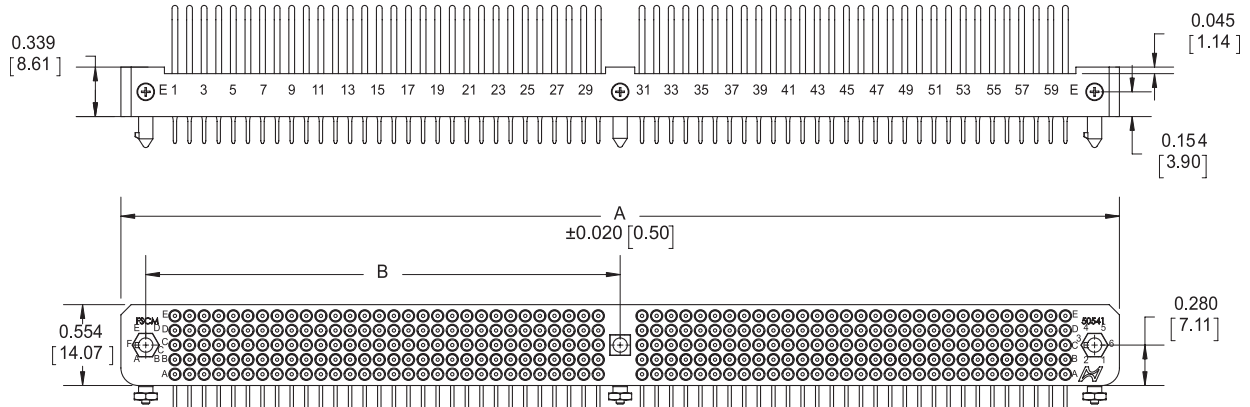

Receptacles

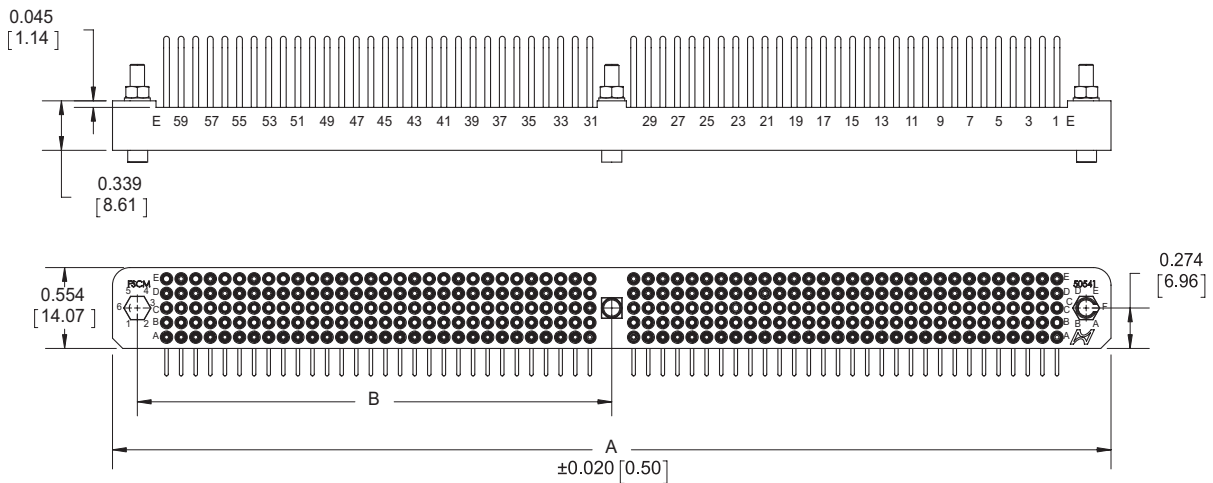

Contacts	A ±0.020 [0.50]	B	Mated pair
300	6.840 [173.74]	3.250 [82.55]	0.678 [17.22]
320	7.240 [183.90]	3.450 [87.63]	
330	7.440 [188.98]	3.550 [90.17]	
390	8.640 [219.46]	4.150 [105.41]	
490	10.640 [270.26]	5.150 [130.81]	

Notes:

1) For insulators longer than 7.00 [178.00], a mother board-daughter board configuration is highly recommended.

Dimensions are in inches [mm] | All content is subject to change without notice

Termination Styles *Dimensions & Specifications⁽¹⁾*

Style B

Right Angle Through-Hole Solder

For 0.125 [3.18] PC board

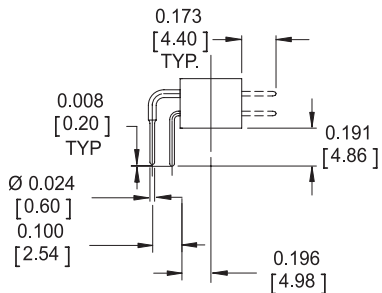
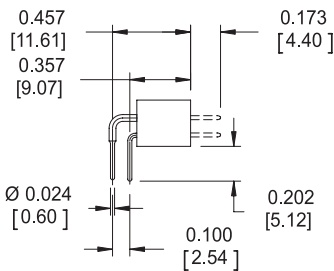
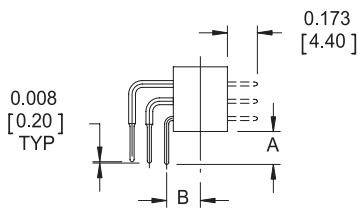
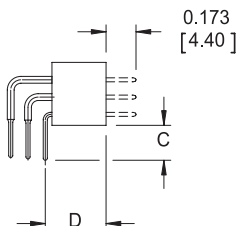
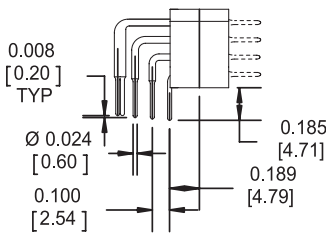
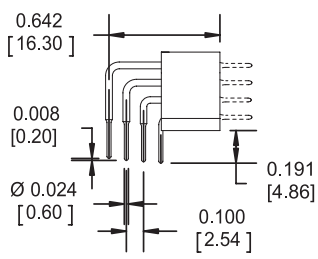
Terminations (female or male)		Rows	Configurations	A	B	C	D
Plugs	Receptacles						
		2 Row	All (17 to 120)	-	-	-	-
		3 Row	62, 80.1, 98 & 126	0.191 [4.86]	0.200 [5.08]	0.201 [5.11]	0.354 [8.98]
		3 Row	160	0.178 [4.53]	0.188 [4.78]	0.188 [4.78]	0.342 [8.68]
		4 Row	All (48 to 392)	-	-	-	-
		5 Row	All (125 to 490)	-	-	-	-

Notes:

1) All tail lengths are ± 0.015 [0.40] long.

Dimensions are in inches [mm] | All content is subject to change without notice

Style C

Right Angle Through-Hole Solder

For 0.063 [1.59] PC board

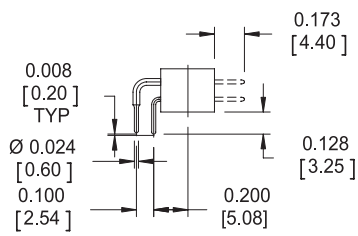
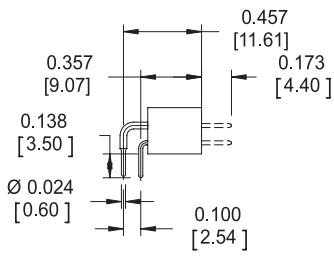
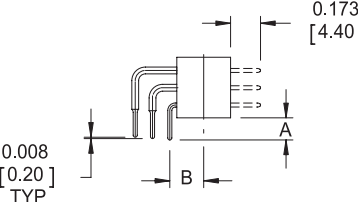
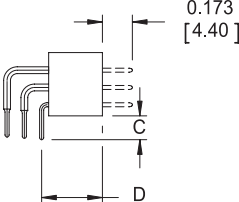
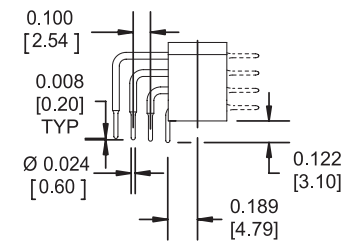
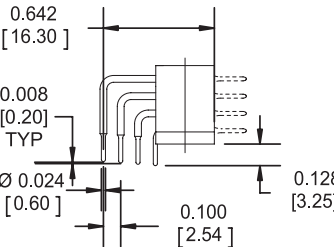
Terminations (female or male)		Rows	Configurations	A	B	C	D
Plugs	Receptacles						
		2 Row	All (17 to 120)	-	-	-	-
		3 Row	62, 80.1, 98 & 126	0.128 [3.25]	0.200 [5.08]	0.138 [3.50]	0.354 [8.98]
			160	0.115 [2.92]	0.188 [4.78]	0.125 [3.17]	0.342 [8.68]
		4 Row	All (48 to 392)	-	-	-	-
		5 Row	All (125 to 490)	-	-	-	-

Style D/DD/FD

Straight Through-Hole Solder

For 0.125 [3.18] PC board

Terminations (female or male)		Style	Rows	Configurations
Plugs	Receptacles			
<p> $\varnothing 0.024$ [0.60] 0.221 [5.62] 0.173 [4.40] </p>	<p> $\varnothing 0.024$ [0.60] 0.221 [5.62] 0.173 [4.40] </p>	D	2 Row	All (17 to 120)
			3 Row	All (62 to 160)
-	<p> $\varnothing 0.024$ [0.60] 0.197 [5.00] </p>	D 0.4 front removable version	3 Row	160
<p> $\varnothing 0.024$ [0.60] 0.181 [4.61] </p>	<p> $\varnothing 0.024$ [0.60] 0.181 [4.61] </p>	D	4 Row	All (48 to 392)
			5 Row	All (125 to 490)
<p> $\varnothing 0.024$ [0.60] 0.147 [3.73] </p>	<p> $\varnothing 0.024$ [0.60] 0.147 [3.73] </p>	DD ⁽¹⁾	4 Row	All (48 to 392)
			5 Row	All (125 to 490)
<p> $\varnothing 0.024$ [0.60] 0.181 [4.61] </p>	<p> $\varnothing 0.024$ [0.60] 0.181 [4.61] </p>	FD ⁽¹⁾ front removable version	4 Row	160
			5 Row	160

Notes:

1) Consult factory for availability

Dimensions are in inches [mm] | All content is subject to change without notice

Style H2

Double Crimp (for insulation)

Accepts 22 to 26 AWG wire stripped back 0.146 [3.70]

Terminations (female or male)		Wire gauge	Rows	Configurations
Plugs	Receptacles			
		22, 24 & 26 AWG	2 Row	All (17 to 120)
			3 Row	All (62 to 160)
		22 & 26 AWG	4 Row	All (48 to 392)
			5 Row	All (125 to 490)

Style R

Crimp⁽¹⁾

Accepts 22, 24 and 26 AWG wire stripped back 0.173 [4.40]

Terminations (female or male)		Wire gauge	Rows	Configurations
Plug	Receptacles			
		22, 24 & 26 AWG	2 Row	All (17 to 120)
			3 Row	All (62 to 160)
		22, 24 & 26 AWG	4 Row	All (48 to 392)
			5 Row	All (125 to 490)

Notes:

1) Crimp contacts will be shipped unmounted. When inserting into the blocks/insulators be sure that the rear is aligned with the flats in the insulator. Dimensions are in inches [mm] | All content is subject to change without notice

Style S

Solder Cup

Accepts up to 22 AWG wire stripped back 0.126 [3.20]

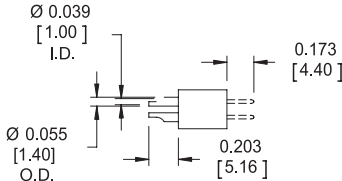
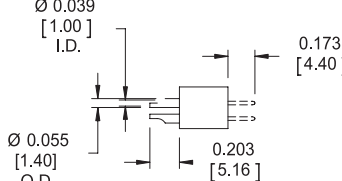
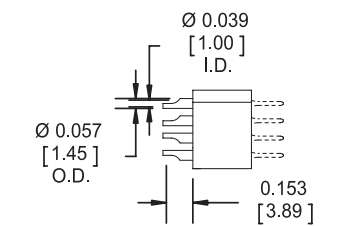
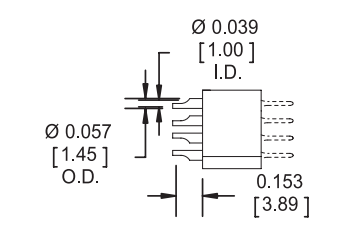
Terminations (female or male)		Wire gauge	Rows	Configurations
Plugs	Receptacles			
		22, 24 & 26 AWG	2 Row	All (17 to 120)
			3 Row	All (62 to 160)
		22 & 26 AWG	4 Row	All (48 to 392)
			5 Row	All (125 to 490)

Style W⁽²⁾

Wire Wrap[®] (2 wraps)

Accepts 28 and 30 AWG wire

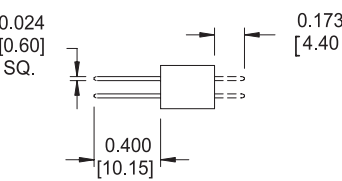
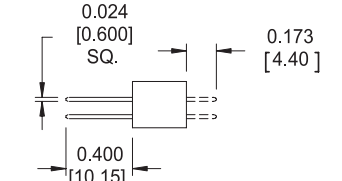
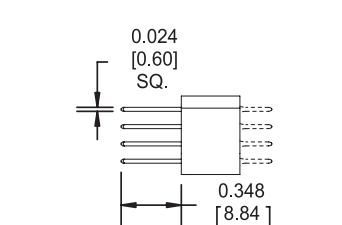
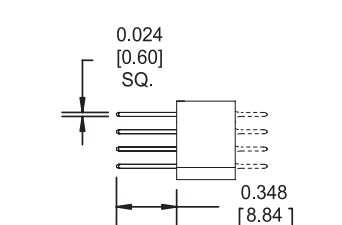
Terminations (female or male)		Wire gauge	Rows	Configurations
Plugs	Receptacles			
		28 & 30 AWG	2 Row	All (17 to 120)
			3 Row	All (62 to 160)
		28 & 30 AWG	4 Row	All (48 to 392)
			5 Row	All (125 to 490)

Notes:

- 1) Solder cup access cut-aways will be oriented staggered as shown for commercial parts. Connectors ordered to "D55302" style part numbers have all cut-aways oriented in the same direction.
- 2) Consult factory for availability.

Dimensions are in inches [mm] | All content is subject to change without notice

Style Y⁽¹⁾

Wire Wrap[®] (2 or 3 wraps)

Accepts 24 to 30 AWG wire

Terminations (female or male)		Rows	Configurations	Wraps	Wire gauge
Plugs	Receptacles				
		2 Row	All (17 to 120)	2 Wraps	24 & 26 AWG
		3 Row	All (62 to 160)	3 Wraps	28 & 30 AWG
		4 Row	All (48 to 392)	2 Wraps	24 & 26 AWG
		5 Row	All (125 to 490)	3 Wraps	28 & 30 AWG

Replacement Contacts *Part Number Reference*

Style	Rows	Standard sockets	Standard pins	Beryllium copper pins
B	Row 1	YSK006-028AH	YPN006-034G or H	YPN006-072H
	Row 2	YSK006-029AH	YPN006-035G or H	YPN006-075H
	Row 3	YSK006-030AH	YPN006-036G or H	YPN006-073H
	Row 4	YSK006-074AH	YPN006-148G or H	—
	Row 5	YSK006-094AH	YPN006-172G or H	—
C	Row 1	YSK006-013AH	YPN006-023G or H	YPN006-048H
	Row 2	YSK006-006AH	YPN006-016G or H	YPN006-050H
	Row 3	YSK006-014AH	YPN006-024G or H	YPN006-077H
	Row 4	YSK006-090AH	YPN006-159G or H	—
	Row 5	YSK006-092AH	YPN006-171G or H	—
D	All	YSK006-005ANH ⁽²⁾	YPN006-015G or H	YPN006-049H
DD	All	YSK006-096ANH	YPN006-106G or H	—
FD⁽³⁾	All	YSK006-274AH	YPN006-470G or H	YPN006-487H
H2	All	YSK006-009AH	YPN006-019G or H	—
R	All	YSK006-011ANH	YPN006-021G or H	—
S	All	YSK006-010ANH	YPN006-020G or H	—
W	All	YSK006-020AH	YPN006-039G or H	—
Y	All	YSK006-012AH	YPN006-022G or H	—

Notes:

1) Consult factory for availability

2) Front removable version: YSK006-027AH

3) Front removable contact for standard housing

Dimensions are in inches [mm] | All content is subject to change without notice

Standard Mounting Hardware *Style & Dimensions*

Style 10

Plug Only

Recommended for B and C contact terminations (*H2, R and S optional*)

2 & 3 Row

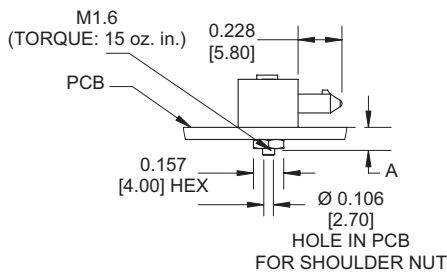

4 & 5 Row

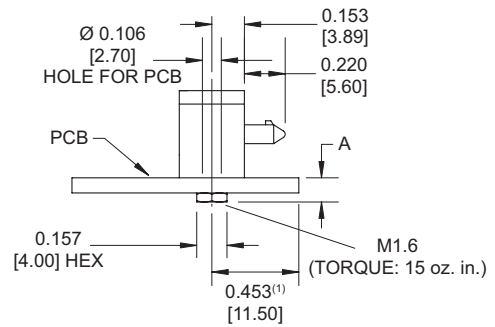

Contacts	A	
	Termination B	Termination C
2 ROW	0.191 [4.85]	0.124 [3.15]
3 ROW	0.220 [5.59] (KA160: 0.207 [5.25])	0.141 [3.58] (KA160: 0.128 [3.25])
4 ROW	0.203 [5.16]	0.164 [4.16]
5 ROW	0.232 [5.89]	0.153 [3.89]

Style 11

Plug/Receptacle

Recommended for D, H2, R and S contact terminations (*W and Y optional*)

2 & 3 Row

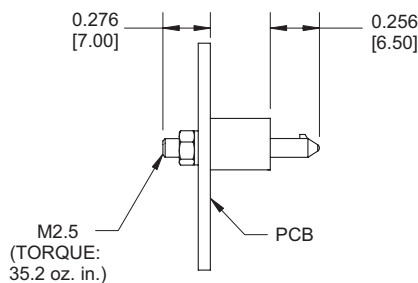

4 & 5 Row

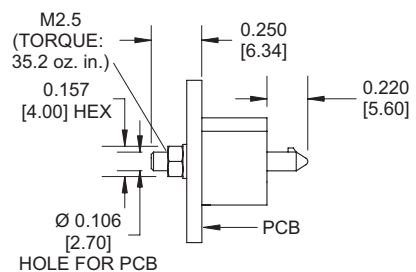

Notes:

1) PCB may be extended to 0.453 [11.50] max. for use as a pin protector.

Dimensions are in inches [mm] | All content is subject to change without notice

Style 12

Plug Only

Recommended for D contact terminations only

2 Row only

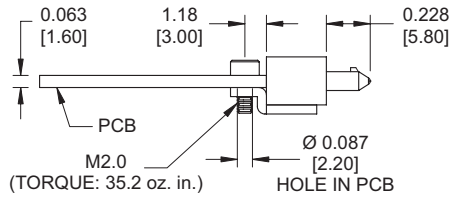

Style 13 | Float Mounting

Plug/Receptacle

Recommended for H2, R and S contact terminations

Radial float is 0.020 [0.50] from center

2 & 3 Row

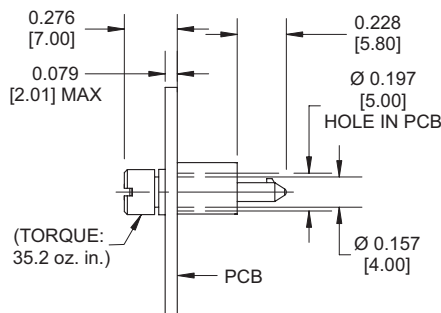

4 & 5 Row

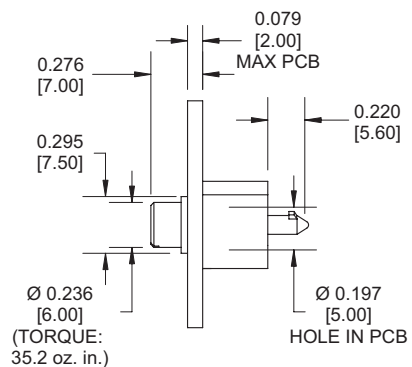

Style 14

Receptacle Only

Recommended for B and C contact terminations (H2, R and S optional)

2 & 3 Row

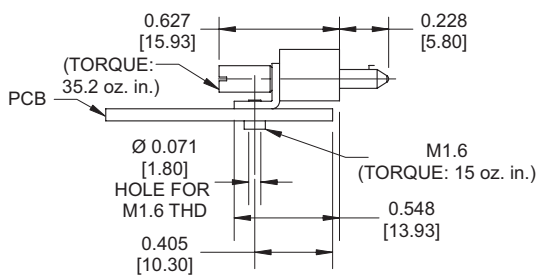

4 & 5 Row

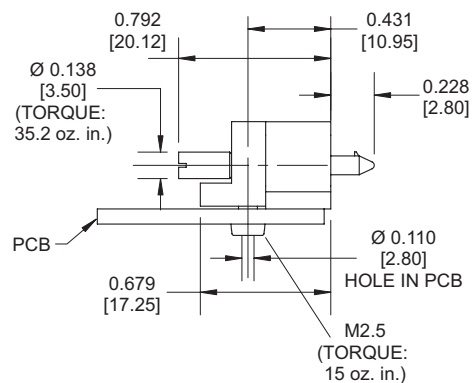

Style 21

Plug/Receptacle

Recommended for D, H2, R and S contact terminations (*W and Y optional*)

2 & 3 Row

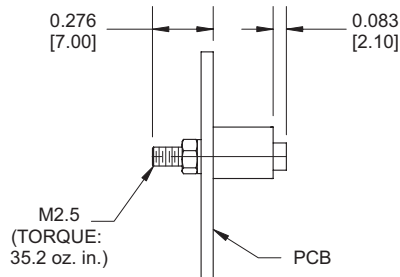

4 & 5 Row

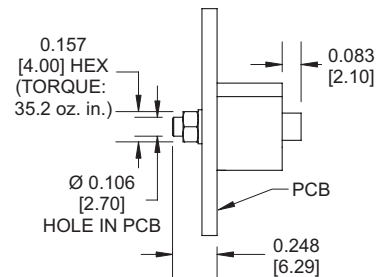

Style 23 / Float Mounting

Plug/Receptacle

Recommended for D, H2, R and S contact terminations (*W and Y optional*)

2 & 3 Row

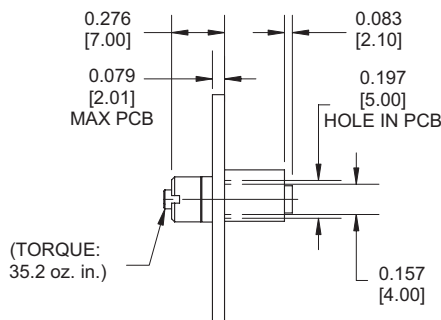

4 & 5 Row

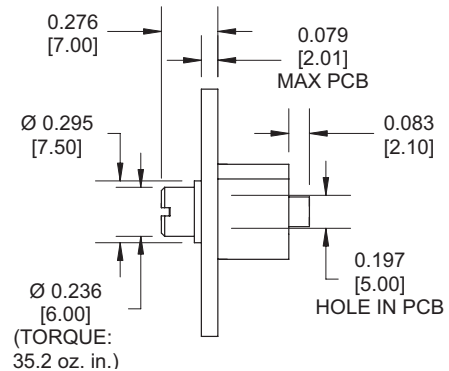

Style 24

Plug/Receptacle

Recommended for B and C contact terminations (*H2, R and S optional*)

2 & 3 Row

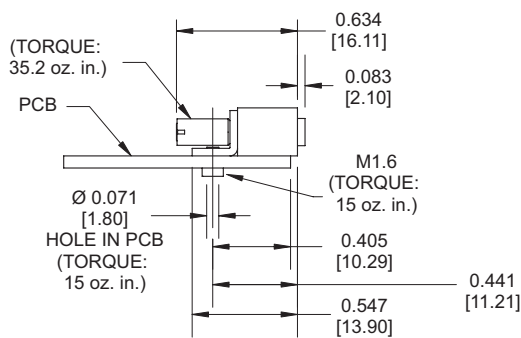

4 & 5 Row

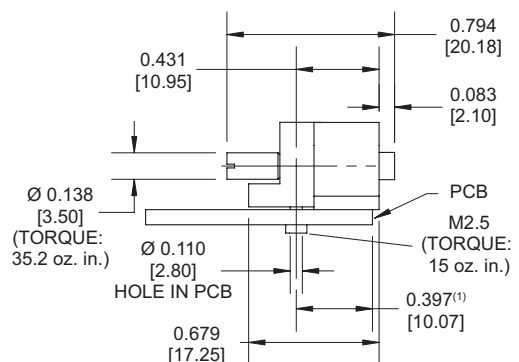

Notes:

1) PCB may be extended to 0.453 [11.50] max. for use as a pin protector.

Dimensions are in inches [mm] | All content is subject to change without notice

Style 101

Plug Only

Recommended for B and C contact terminations (*H2, R and S optional*)

2 & 3 Row

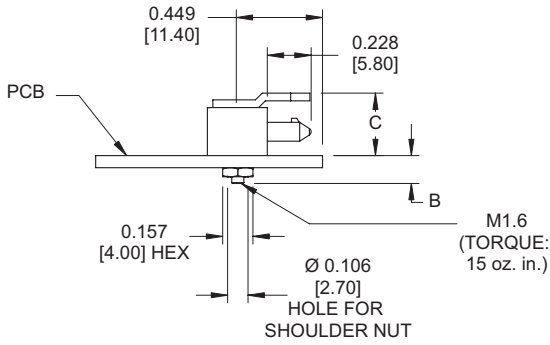

4 & 5 Row

(with pin protector)

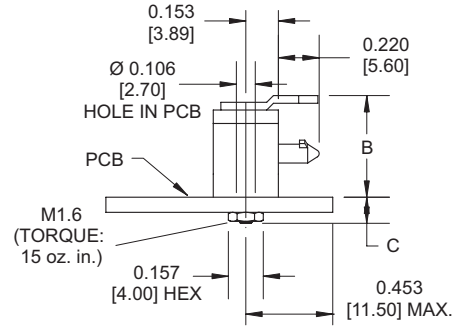

Contacts	B		C
	Termination B	Termination C	
2 ROW	0.204 [5.18]	0.165 [4.18]	0.343 [8.71]
3 ROW	0.218 [5.53] (KA160: 0.205 [5.20])	0.139 [3.53] (KA160: 0.126 [3.20])	0.447 [11.36]
4 ROW	0.541 [13.74]		0.168 [4.26]
5 ROW	0.661 [16.78]		0.236 [5.91]

Style 111

Plug Only

Recommended for B and C contact terminations (*W and Y optional*)

2 & 3 Row

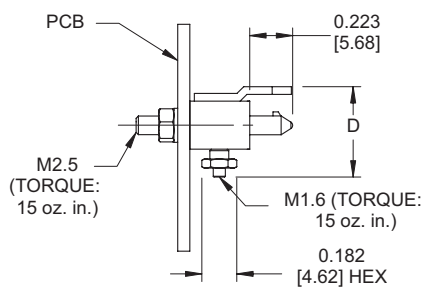

4 & 5 Row

(with pin protector)

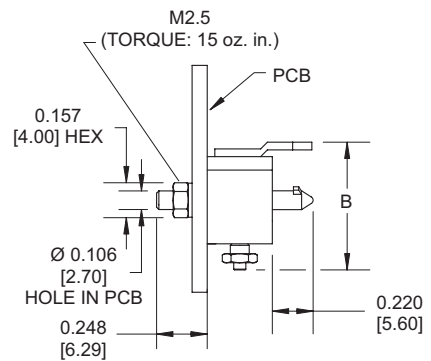

Contacts	B	D
2 ROW	—	0.486 [11.89]
3 ROW	—	0.586 [14.89]
4 ROW	0.781 [19.84]	—
5 ROW	0.900 [22.86]	—

Notes:

1) Right angle mounting screw length is determined by contact terminal length.

Dimensions are in inches [mm] | All content is subject to change without notice

Style 121

Plug Only

Recommended for D contact terminations only

2 Row only

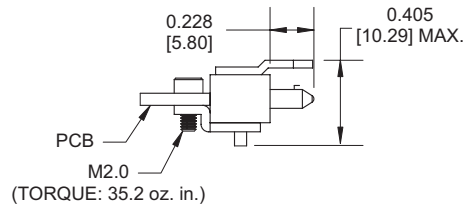

Style 131 / Float Mounting

Plug Only

Recommended for H2, R and S contact terminations

2 & 3 Row

(with pin protector)

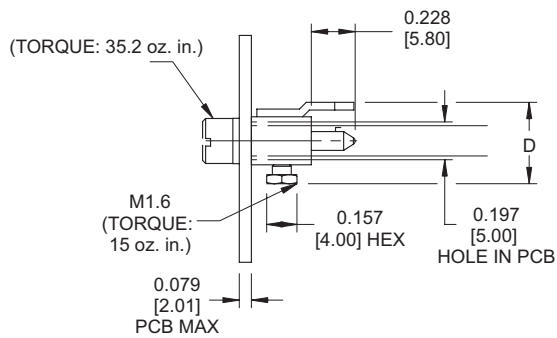

4 & 5 Row

(with pin protector)

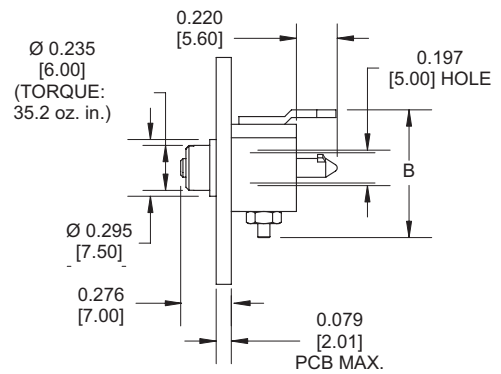

Contacts	B	D
2 ROW	—	0.486 [11.89]
3 ROW	—	0.586 [14.89]
4 ROW	0.781 [19.84]	—
5 ROW	0.900 [22.86]	—

Locking Hardware *Styles & Dimensions*

Style V1

Plug/Receptacle

Push, quarter turn locking method
Recommended for H2, R and S contact terminations

2 & 3 Row

Mates with V2 & V4

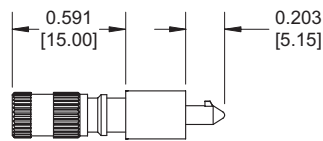

4 & 5 Row

Mates with V2 & V4

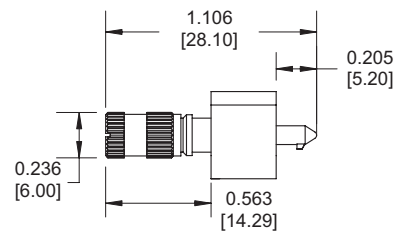

Style V2

Plug/Receptacle

Push, quarter turn locking method
Recommended for D, H2, R and S contact terminations (*W and Y optional*)

2 & 3 Row

Mates with V1, V3 & V6

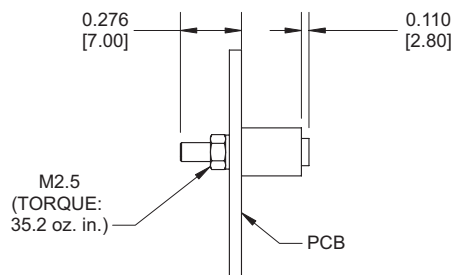

4 & 5 Row

Mates with V1 & V6

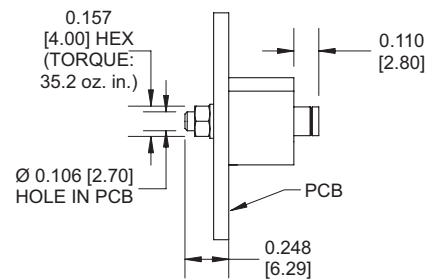

Style V3

Plug Only

Push, quarter turn locking method
Recommended for B and C contact terminations (*H2, R and S optional*)

2 & 3 Row only

Mates with V2 & V4

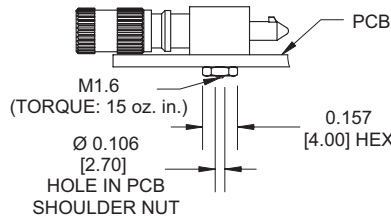

Style V4

Plug/Receptacle

Push, quarter turn locking method
Recommended for B and C contact terminations (*H2, R and S optional*)

2 & 3 Row

Mates with V1, V3 & V6

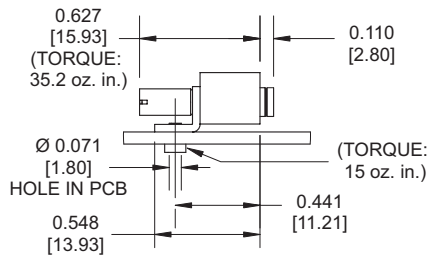

4 & 5 Row

Mates with V1 & V6

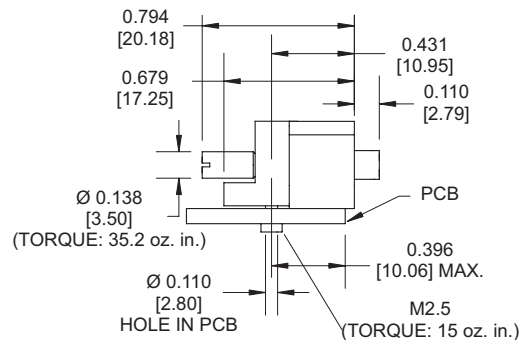

Style V6

Plug Only

Push, quarter turn locking method
Recommended for B and C contact terminations (*H2, R and S optional*)

2 & 3 Row

Mates with V2 & V4

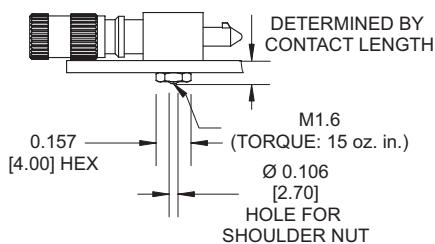

4 & 5 Row

Mates with V2 & V4

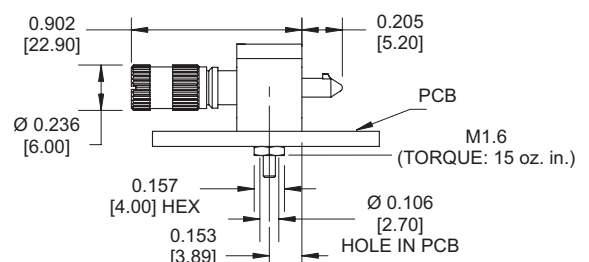

Style V7

Plug/Receptacle

Screw locking method

Recommended for H2, R and S contact terminations

2 & 3 Row

Mates with V8, V9 and V15

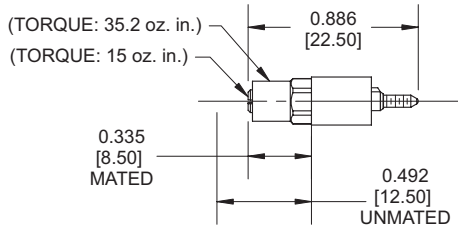

4 & 5 Row

Mates with V9 & V15

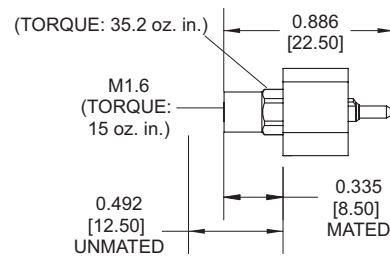

Style V8

Plug Only

Screw locking method

Recommended for B and C contact terminations (H2, R and S optional)

2 & 3 Row only

Mates with V7⁽¹⁾

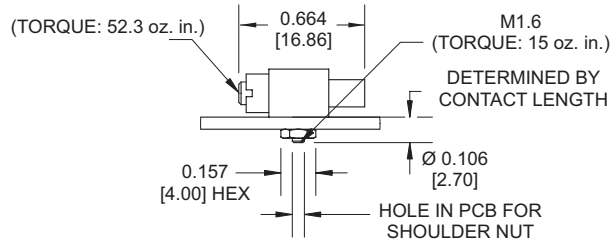

Style V9

Plug Only

Screw locking method

Recommended for B and C contact terminations (H2, R and S optional)

2 & 3 Row

Mates with V7⁽¹⁾

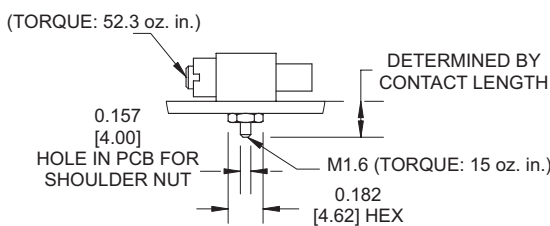

4 & 5 Row

Mates with V7

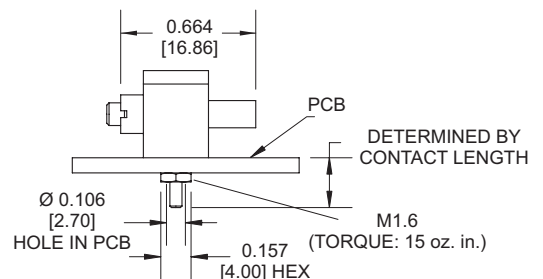

Notes:

- 1) For contact configurations: 62, 80.1, 98 and 160
 - 2) Right angle mounting screw length is determined by contact terminal length
- Dimensions are in inches [mm] | All content is subject to change without notice

Style V15

Plug/Receptacle

Screw locking method

Recommended for D, H2, R and S contact terminations (*W and Y optional*)

2 & 3 Row

Mates with V7

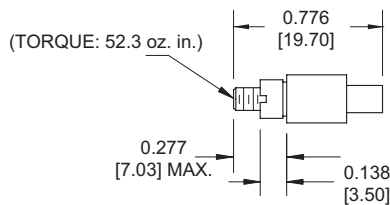

4 & 5 Row

Mates with V7

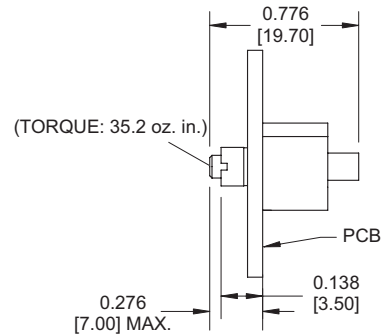

Style V30 | Stationary Jackscrew

Plug Only

Screw locking method

Recommended for B and C contact terminations (*H2, R and S optional*)

2 & 3 Row

Mates with V33

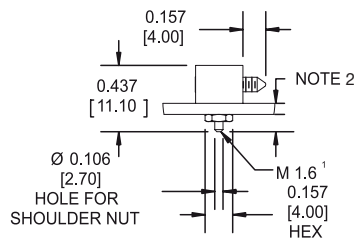

4 & 5 Row

Mates with V33

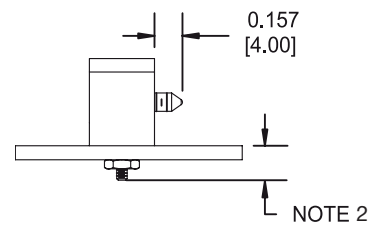

Style V31 | Stationary Jack Socket

Plug/Receptacle

Screw locking method

Recommended for D, H2, R and S contact terminations (*W and Y optional*)

2 & 3 Row

Mates with V32

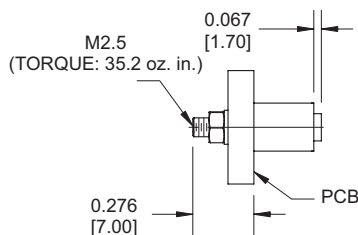

4 & 5 Row

Mates with V32

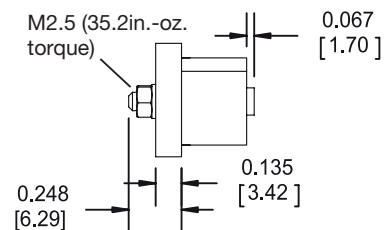

Notes:

- 1) 15.00 oz. in torque.
 - 2) Right angle mounting screw length is determined by contact terminal length.
- Dimensions are in inches [mm] | All content is subject to change without notice

Style V32 | Rotating Jackscrew

Plug/Receptacle

Screw locking method

Recommended for D, H2, R and S contact terminations (*W and Y optional*)

2 & 3 Row

Mates with V31 & V33

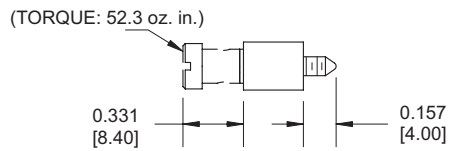

4 & 5 Row

Mates with V31 & V33

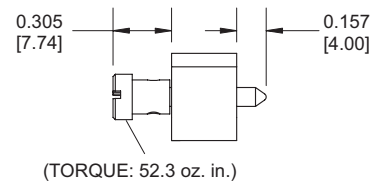

Style V33 | Rotating Jack Socket

Plug/Receptacle

Screw locking method

Recommended for D, H2, R and S contact terminations (*W and Y optional*)

2 & 3 Row

Mates with V30 & V32

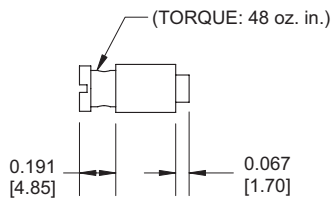

4 & 5 Row

Mates with V30 & V32

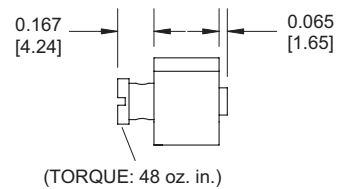

Board Mounting *Applications & Dimensions*

2 Row Connectors

17, 29, 33, 41, 53 & 65 Contacts

PC board shown from component side of board

Contacts	B
17	1.200 [30.48]
29	1.800 [45.72]
33	2.000 [50.8]
41	2.400 [60.96]
53	3.000 [76.20]
65	3.600 [91.44]

Mother board application

Style 11, 21, V2, V15 & V31

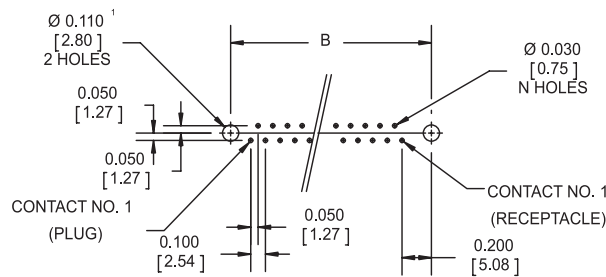

Daughter board application

Style 10, 30, V3, V8 & V30

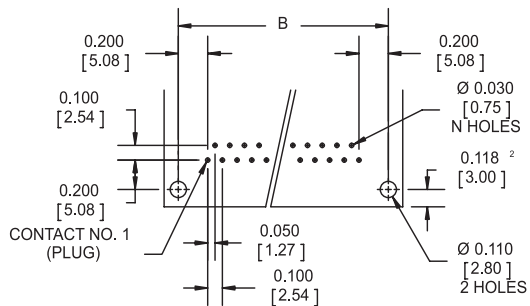

Daughter board application

Style 24 & V4

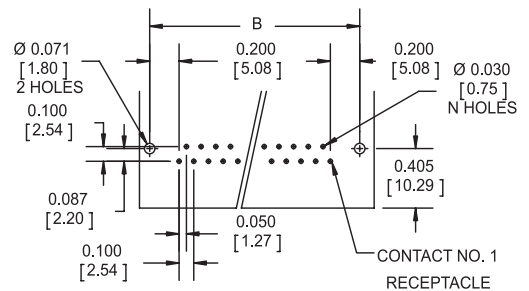

Notes:

- 1) For V15 locking mounting style, dimension is 0.130 ± 0.004 [3.20 ± 0.10] diameter.
- 2) PC board may be extended to 0.453 [11.50] max for use as a pin protector.

Dimensions are in inches [mm] | All content is subject to change without notice

3 Row Connectors

62, 80.1 & 98 Contacts

PC Board shown from component side of board

Contacts	B
62	2.400 [60.96]
80.1	3.000 [76.20]
98	3.600 [91.44]

Mother board application

Style 11, 21, V2, V15 & V31

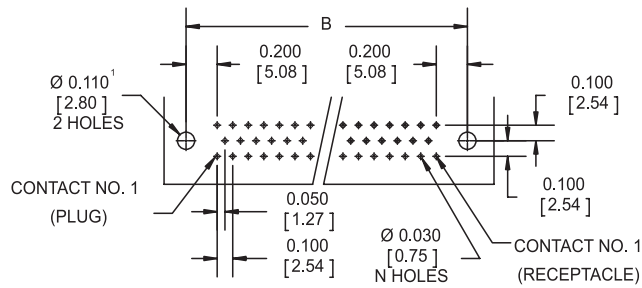

Daughter board application

Style 10, 30, V3, V8 & V30

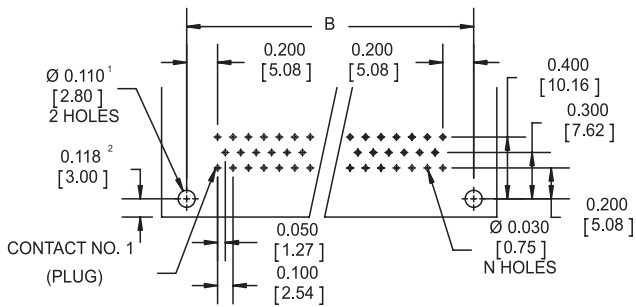

Daughter board application

Style 24 & V4

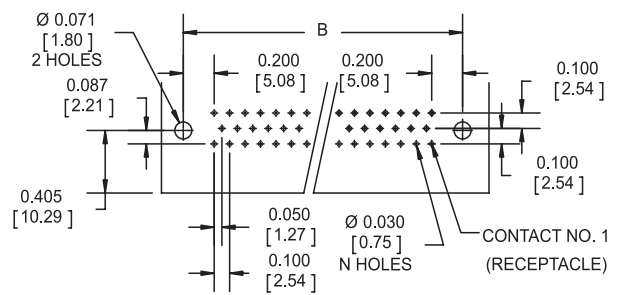

Notes:

- 1) For V15 locking mounting style, dimension is 0.130 ± 0.004 [3.20 ± 0.10] diameter.
- 2) PC board may be extended to 0.453 [11.50] max for use as a pin protector.

Dimensions are in inches [mm] | All content is subject to change without notice

2 & 3 Row Connectors

72, 84, 96, 120 & 126 Contacts

PC Board shown from component side of board

Contacts	B	C
72	2.100 [53.34]	4.200 [106.68]
84	2.400 [60.96]	4.800 [121.92]
96	2.700 [68.58]	5.400 [137.16]
120	3.300 [83.82]	6.600 [167.64]
126	2.400 [60.96]	4.800 [121.92]

Mother board application

Style 11, 21, V2, V15 & V31

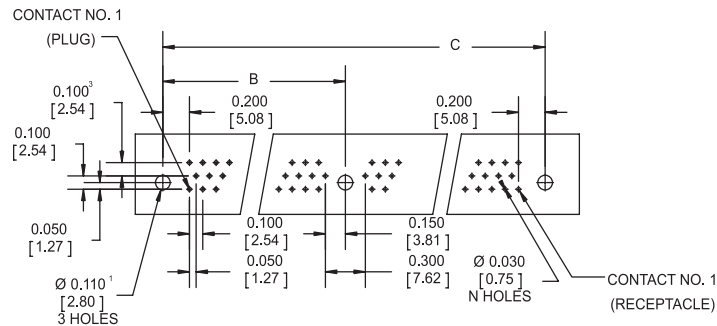

Daughter board application

Style 10, 30, V3, V8 & V30

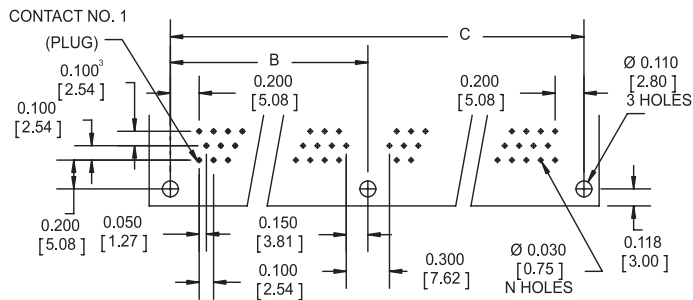

Daughter board application

Style 24 & V4

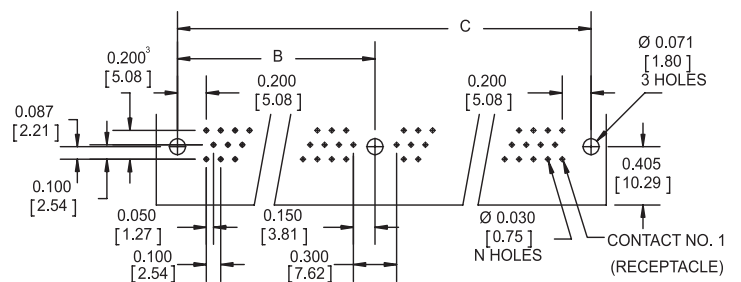

Notes:

- 1) For V15 locking mounting style, dimension is 0.130 ± 0.004 [3.20 ± 0.10] diameter.
- 2) PC board may be extended to 0.453 [11.50] max for use as a pin protector.
- 3) Third row is for 126 pin version only.

Dimensions are in inches [mm] | All content is subject to change without notice

3 Row Connectors

160 & 160.4 Contacts

PC Board shown from component side of board

Contacts	B	C
160	2.950 [74.93]	5.900 [149.86]
160.4	2.950 [74.93]	5.900 [149.86]

Mother board application

Style 11, 21, V2, V15 & V31

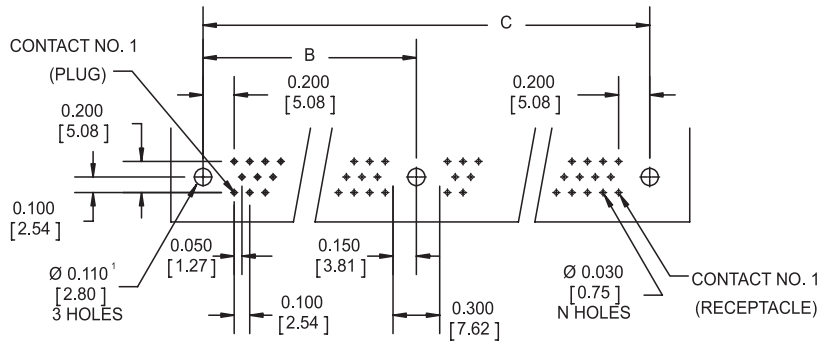

Daughter board application

Style 10, 30, V3, V9 & V30

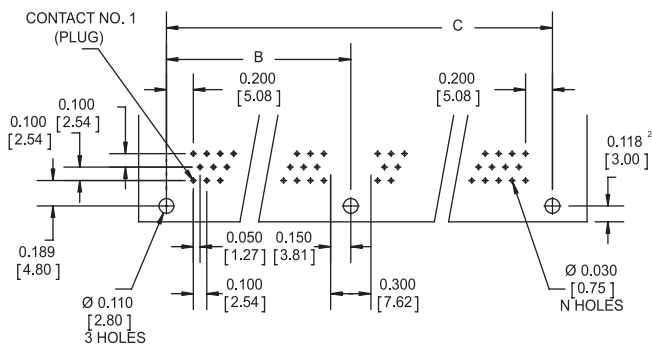

Daughter board application

Style 24 & V4

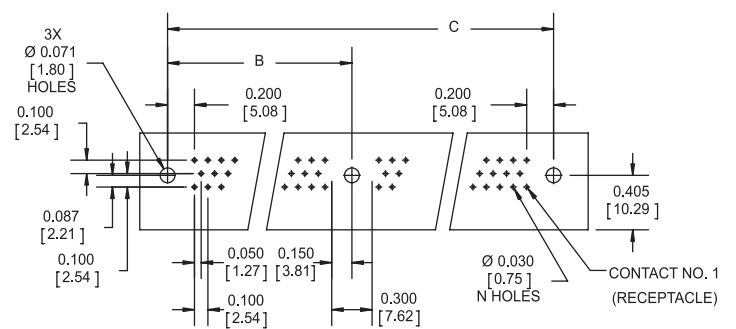

Notes:

- 1) For V15 locking mounting style, dimension is 0.130 ± 0.004 [3.20 ± 0.10] diameter.
- 2) PC board may be extended to 0.453 [11.50] max for use as a pin protector.

Dimensions are in inches [mm] | All content is subject to change without notice

4 & 5 Row Connectors

48 to 490 Contacts

Contacts	X
48	1.500 [38.10]
68	2.000 [50.80]
80	2.300 [58.42]
96	2.700 [68.58]
100	2.800 [71.12]
108	3.000 [76.20]
120	3.300 [83.82]
125	2.800 [71.12]
128	3.500 [88.90]
136	3.700 [93.98]
140	3.100 [78.74]
160	4.300 [109.22] (4 row) 3.500 [88.92] (5 row)
184	4.900 [124.46]
196	5.200 [132.08]

Contacts	X
200	4.300 [109.22]
208	5.700 [144.78]
228	6.000 [152.40]
230	4.900 [124.46]
240	6.500 [165.10] (4 row) 5.100 [129.54] (5 row)
264	7.100 [180.34]
300	6.500 [165.10]
320	6.900 [175.26]
330	7.100 [180.34]
352	9.300 [236.22]
390	8.300 [210.82]
392	10.300 [261.62]
490	10.300 [261.62]

Mother board application

Style 11, 21, V2 & V31

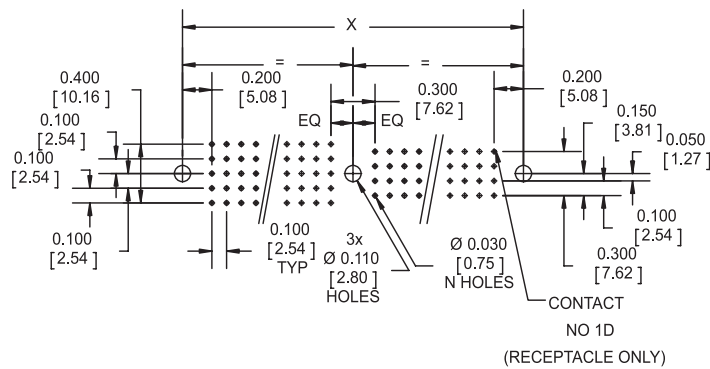

Daughter board application

Style 10, 30, V3, V9 & V30

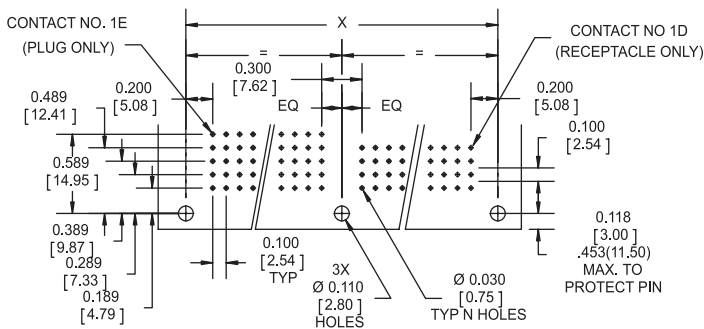

Daughter board application

Style 14, 24 & V4

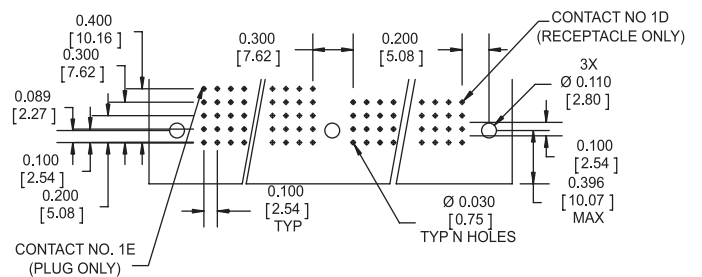

Panel Cutouts

Fixed & Float Mounting Styles & Dimensions

2 Row Connectors

17, 29, 33, 41, 53 & 65 Contacts

Contacts	B
17	1.200 [30.48]
29	1.800 [45.72]
33	2.000 [50.8]
41	2.400 [60.96]
53	3.000 [76.20]
65	3.600 [91.44]

Fixed mounting Styles 11, 21, V2, V15 & V31

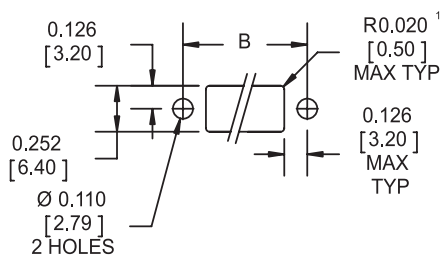

Float mounting Styles 13 & 23

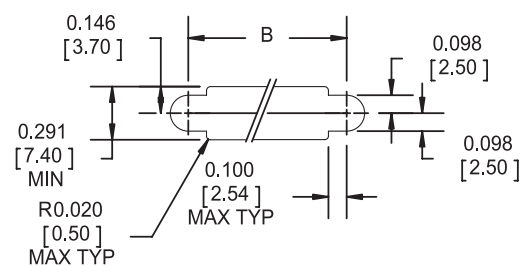

3 Row Connectors

62, 80.1 & 98 Contacts

Contacts	B
62	2.400 [60.96]
80.1	3.000 [76.20]
98	3.600 [91.44]

Fixed mounting Styles 11, 21, V2, V15 and V31

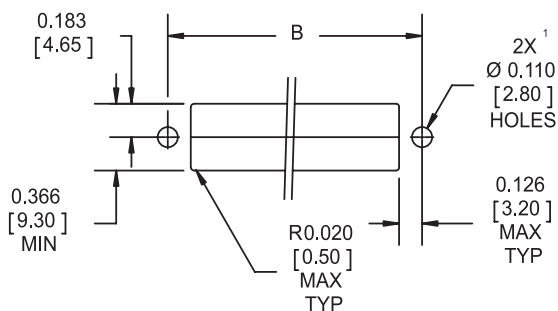

Float mounting Styles 13 & 23

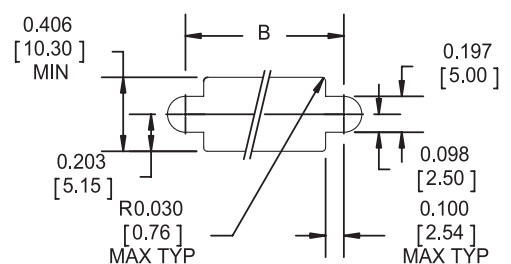

Notes:

1) For V15 locking mounting style, dimension is 0.130 ± 0.004 [3.20 ± 0.10] dia.
Dimensions are in inches [mm] | All content is subject to change without notice

3 Row Connectors

72, 84, 120 & 126 Contacts

Contacts	B	C	D _{MIN}	E _{MIN}
72	2.100 [53.34]	4.200 [106.68]	0.252 [6.40]	0.291 [7.50]
84	2.400 [60.96]	4.800 [121.92]	0.252 [6.40]	0.291 [7.50]
96	2.700 [68.58]	5.400 [137.16]	0.252 [6.40]	0.291 [7.50]
120	3.300 [83.82]	6.600 [167.64]	0.252 [6.40]	0.291 [7.50]
126	2.400 [60.96]	4.800 [121.92]	0.366 [9.30]	0.406 [10.30]

Fixed mounting
Styles 11, 21, V2, V15 & V31

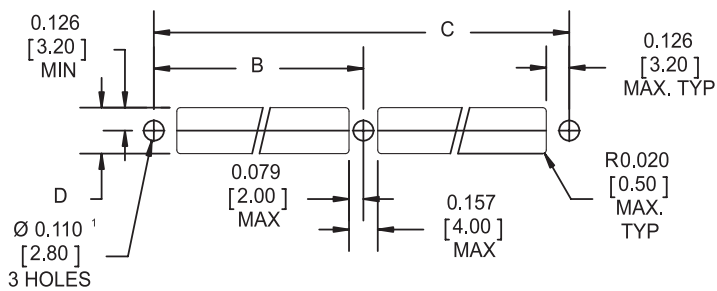

Float mounting
Styles 13 & 23

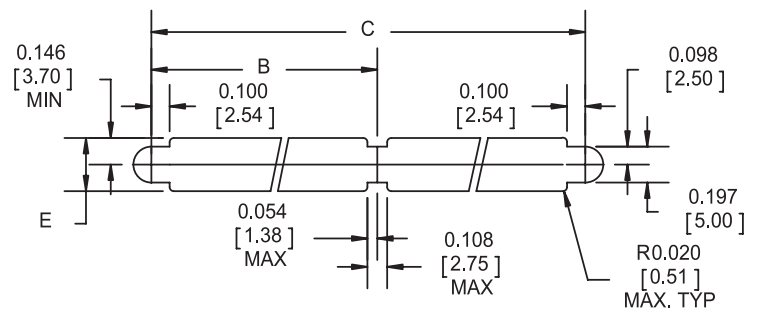

3 Row Connectors

160 & 160.4 Contacts

Contacts	B	C
160	2.950 [74.93]	5.900 [149.86]
160.4	2.950 [74.93]	5.900 [149.86]

Fixed mounting
Styles 11, 21, V2, V15 & V31

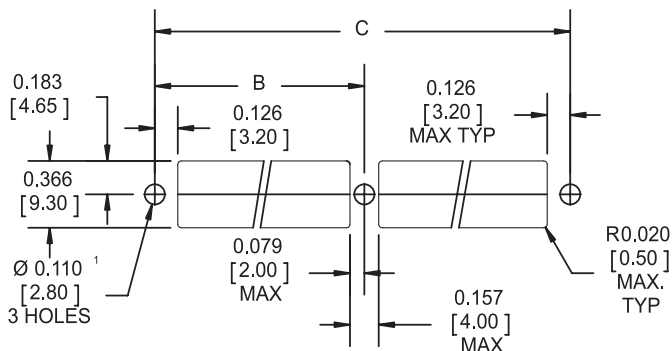

Float mounting
Styles 13 & 23

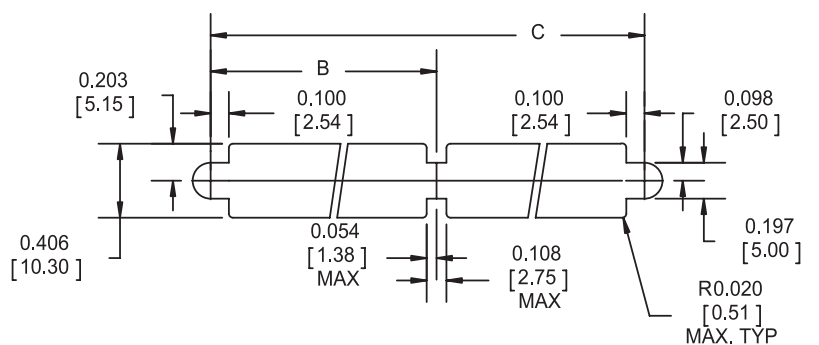

4 & 5 Row Connectors

48 to 490 Contacts

Center hole not required for 48 to 184 contacts

Contacts	X
48	1.500 [38.10]
68	2.000 [50.80]
80	2.300 [58.42]
96	2.700 [68.58]
100	2.800 [71.12]
108	3.000 [76.20]
120	3.300 [83.82]
125	2.800 [71.12]
128	3.500 [88.90]
136	3.700 [93.98]
140	3.100 [78.74]
160	4.300 [109.22] (4 row) 3.500 [88.92] (5 row)
184	4.900 [124.46]
196	5.200 [132.08]

Contacts	X
200	4.300 [109.22]
208	5.700 [144.78]
228	6.000 [152.40]
230	4.900 [124.46]
240	6.500 [165.10] (4 row) 5.100 [129.54] (5 row)
264	7.100 [180.34]
300	6.500 [165.10]
320	6.900 [175.26]
330	7.100 [180.34]
352	9.300 [236.22]
390	8.300 [210.82]
392	10.300 [261.62]
490	10.300 [261.62]

Fixed mounting Style 11, 21, V2 & V31

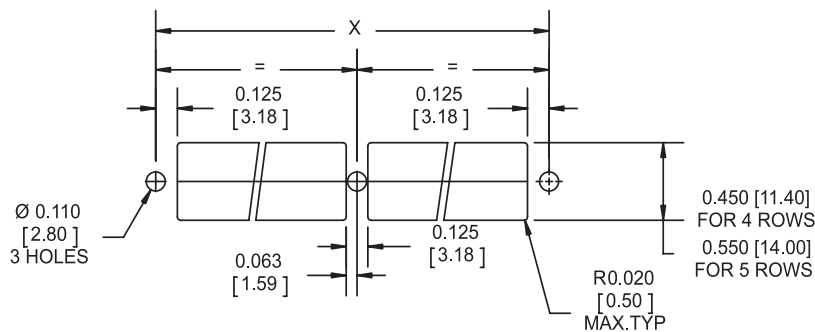

Float mounting Style 13 & 23

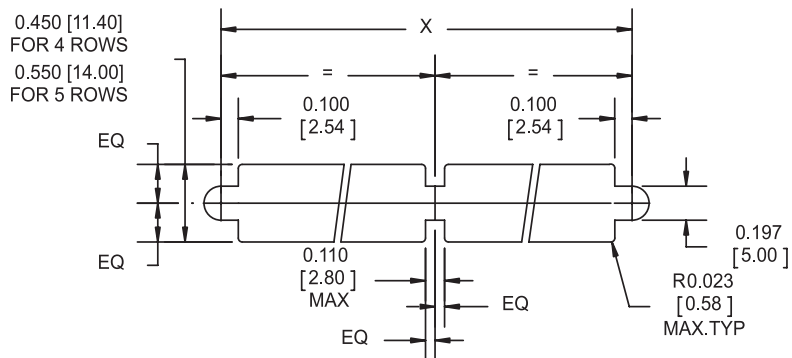

Notes:
 1) For connectors with center guide float mounts, rows adjacent to center guide will not be loaded. Example: a KA490 will actually have 480 contacts; a KA392 will actually have 384 contacts.

Dimensions are in inches [mm] | All content is subject to change without notice

Accessories *Insertion, Extraction, & Crimp Tooling*

Optional tools

Insertion Tool	S/MONT 1.00600
Spanner Wrench	T136 <i>(for receptacle with front removable contacts)</i>
Extraction Tool	S/DEM 1.0060

Crimp tools

Style R & H2 1 Crimp	
Manual Crimp Tool	MS3198.1 or M22520/2-01 or AFM8
Positioner For Contacts	K547
Style H2 2 Crimps in 2 Operations	
Manual Crimp Tool	MS3198.1 or M22520/2-01 or AFM8
Positioner for Contacts (wire)	K547
Positioner for Contacts (insulation)	K640
Style H2 2 Crimps in Operation⁽¹⁾	
Crimping Instructions Document	S50063

Notes:

1) This requires a special tool. Please submit wire samples and consult factory for further information.

Dimensions are in inches [mm] | All content is subject to change without notice

How To Order

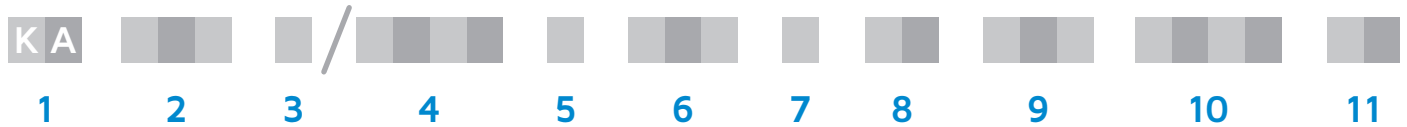

1 KA Series	[Fixed]
2 Number contacts 2 & 3 Row connectors	17 29 33 41 53 62 65 72 80 84 96 98 120 126 160 Contacts
4 & 5 Row connectors	48 68 96 120 125 128 136 140 160 184 196 200 208 228 230 240 264 300 320 330 352 390 392 490 Contacts ⁽¹⁾
3 Contact variants <i>(Omit for standard versions)</i>	.1 For 3 row 80.1 contact version only .4 For 3 row 160.4 contact front removable receptacle only
4 Number rows	/ 1 2 7 B 2 Rows / 1 2 7 C 3 Rows / 2 5 4 D 4 Rows / 2 5 4 E 5 Rows
5 Insulator	P Plug E Receptacle
6 Locking mounting hardware <i>(Omit for non-locking hardware)</i> <i>(Reference pags. 24-28 for intermatibility)</i>	V1 V2 V3 V4 V6 V7 V8 V9 V15 V30 V31 V32 V33 Locking mounting styles
7 Contact gender	M Male F Female
8 Terminal styles	B 90° 0.125 [3.18] PCB C 90° 0.063 [1.59] PCB D Straight PCB DD Short Straight PCB FD Front removable D contacts H2 Double crimp ⁽²⁾ R Crimp S Solder W Wire wrap [2 wraps] Y Wire wrap [3 wraps]
9 Mounting hardware No hardware Mounting styles	00 10 11 12 13 14 21 23 24 101 111 131
10 Termination plating	T 10µin. [0.25 µm.] Gold (min) over Nickel [<i>male only</i>] TH 50µin. [1.27 µm.] Gold (min) over Nickel [<i>male only</i>] TAH 50µin. [1.27 µm.] Gold (min) over Nickel on mating surface [<i>female only</i>] TB or TBH Tin lead option for PC style contacts ⁽³⁾ [<i>male only</i>] TABH Tin lead option for PC style contacts [<i>female only</i>]
11 Keying orientation	A1 [<i>Omit for default keying positions: C&3 for 2&3 row connectors, F&3 for 4&5 row connectors</i>]

Notes:

1) Special sizes from 48 to 392 (4 row) and from 60 to 490 (5 row) are available. Please consult factory.

2) Crimp contacts will be shipped unloaded. When inserting contacts into the insulator, be sure the two flats at the rear of the contact body are aligned with the flats in the insulator.

3) "TB" is "T" with tinned tails, "TBH" is "TH" with tinned tails.

Military Part Number Cross Reference

Smiths Interconnect's Part Number Cross Reference

Slash sheets 159 and 160
 Receptacle 2 Row Insulator Styles
 For 17 to 120 Contact Positions

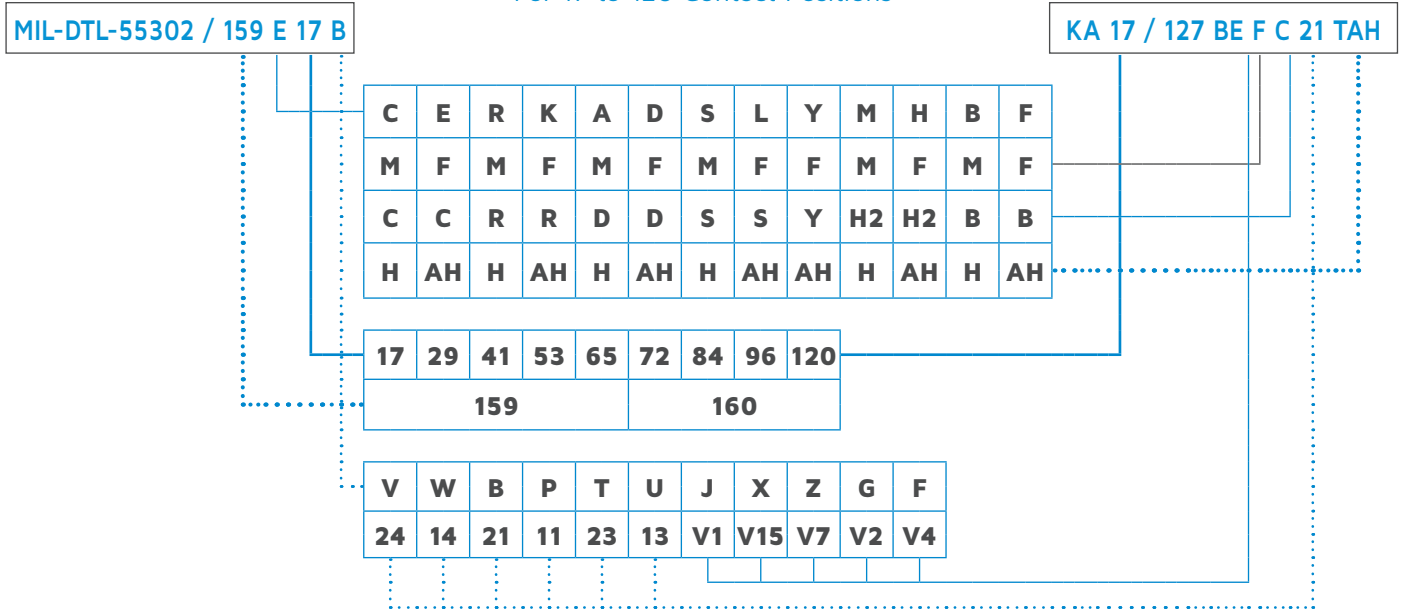

Slash sheets 162 and 163
 Receptacle 2 Row Insulator Styles
 For 17 to 120 Contact Positions

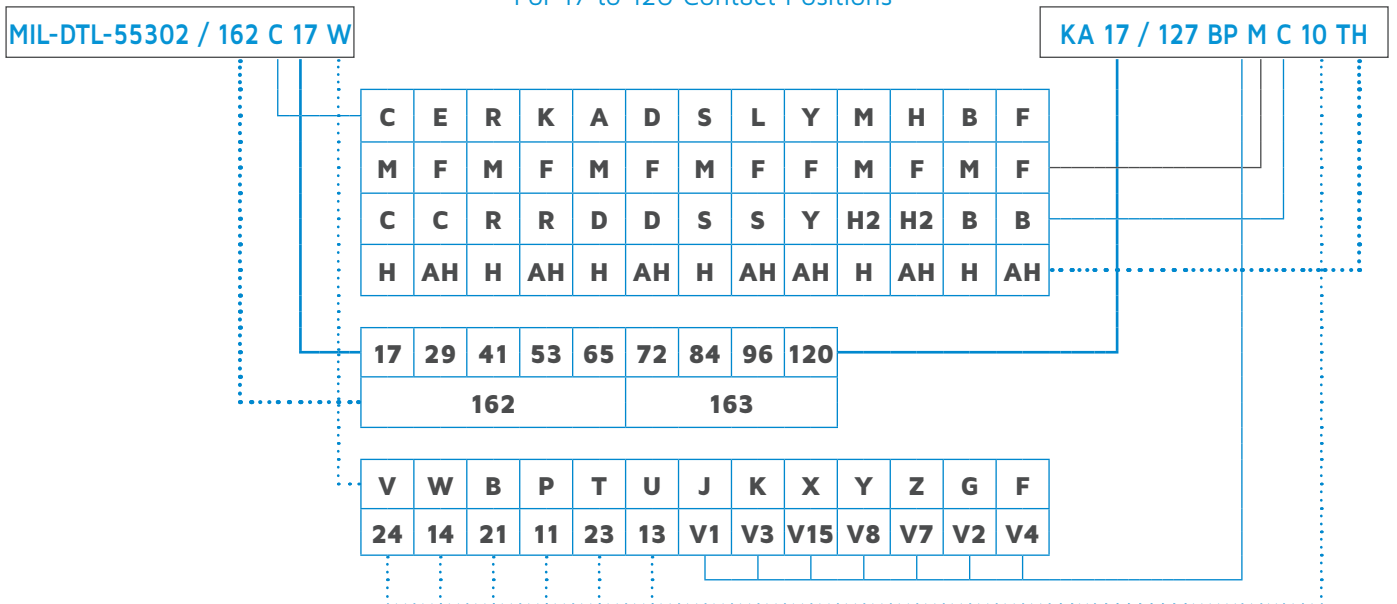

Military Part Number Cross Reference

Smiths Interconnect's Part Number Cross Reference

Slash sheet 161

160 Position Split Shell Receptacles

D55302/161 J 160 G	KA 160.4/127CEFD21TAH
D55302/161 G 160 G	KA 160.4/127CEFY21TAH
D55302/161 P 160 G	KA 160.4/127CEMD21TAH
D55302/161 Q 160 G	KA 160.4/127CEMY21TAH

Slash sheet 164

160 Contact Position Plugs and Receptacles

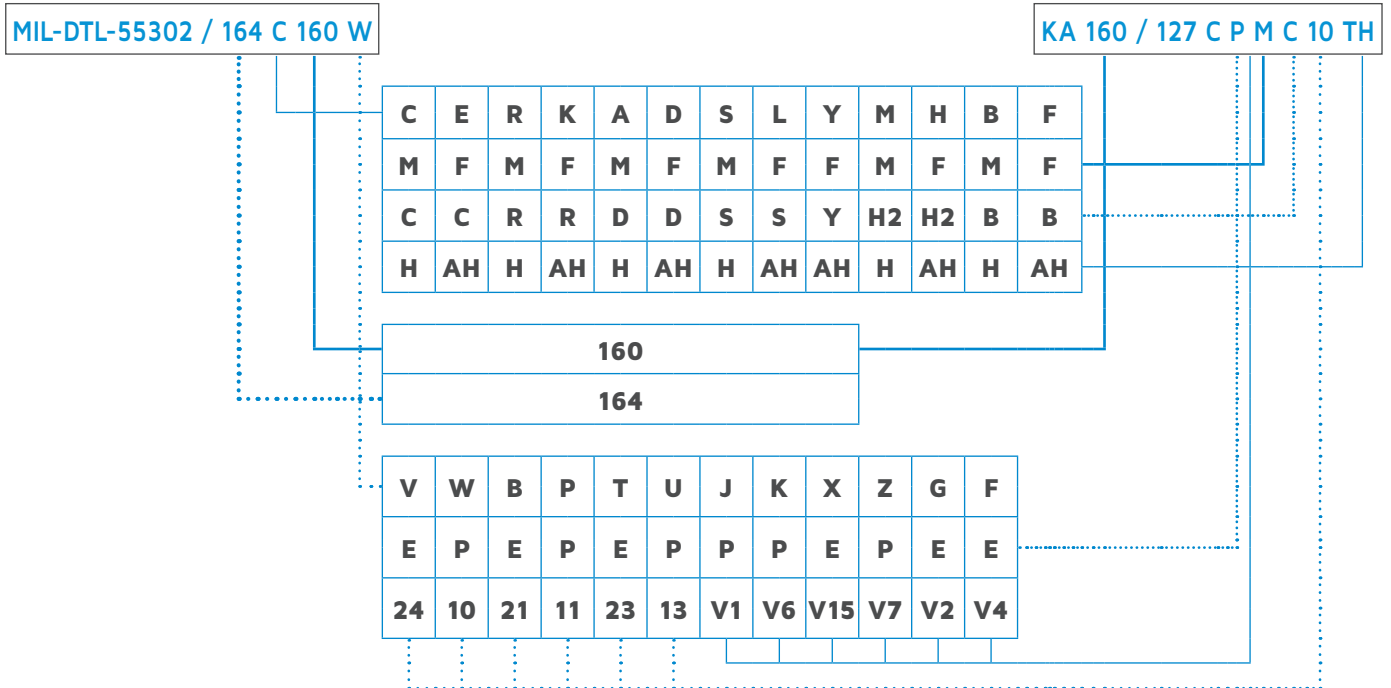

Product Portfolio

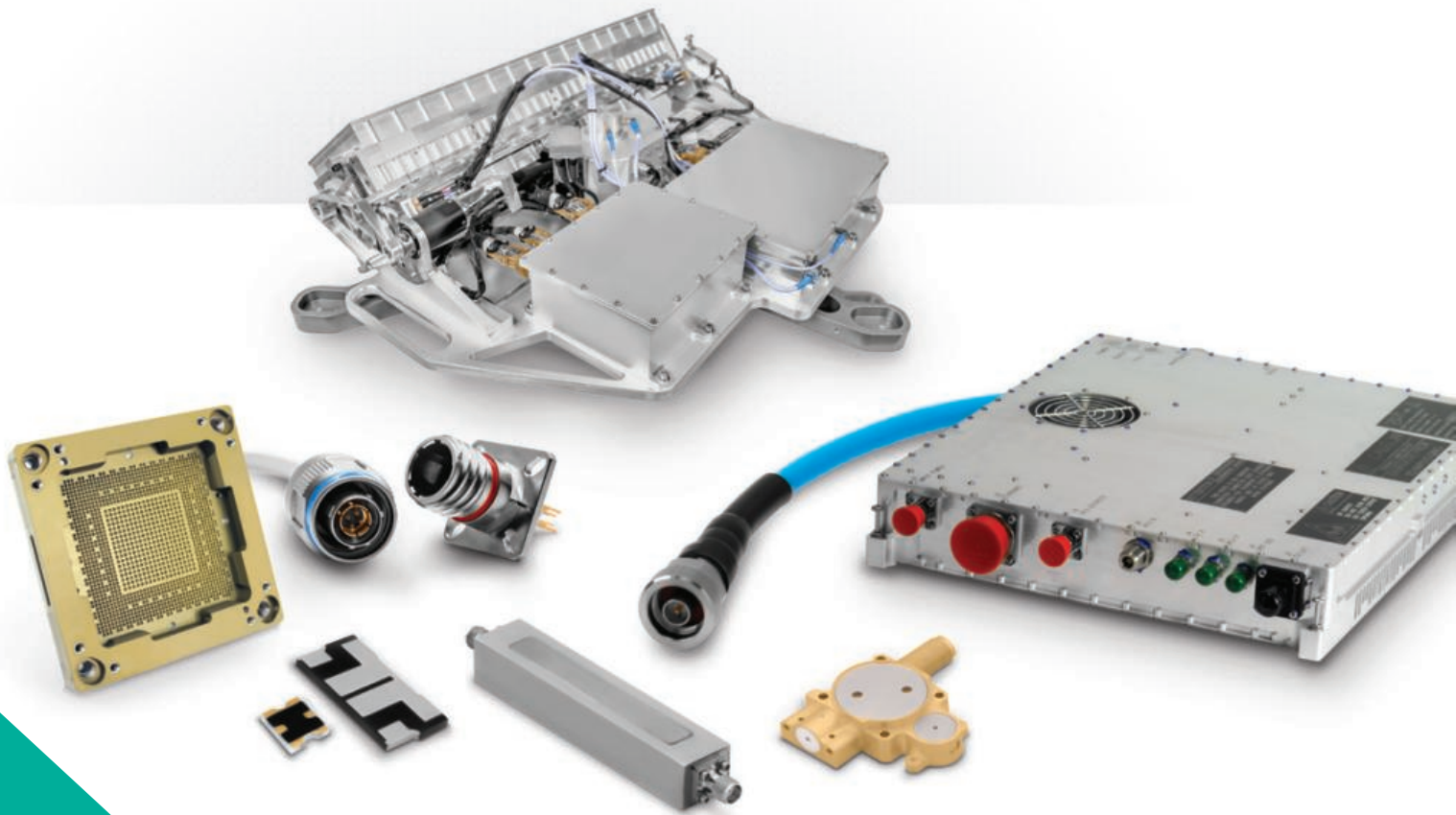

- Antenna Systems
 - Cable Assemblies
 - Connector Solutions
 - Ferrite Components & Assemblies
 - RF Filter Components & Assemblies
 - Integrated Microwave Assemblies
 - Millimeter-Wave Solutions
 - RF Components
 - Test Sockets and WLCSP Probe Heads
 - Time & Frequency Systems

Disclaimer 2022

All of the information included in this catalog is believed to be accurate at the time of printing. It is recommended, however, that users should independently evaluate the suitability of each product for their intended application and be sure that each product is properly installed, used and maintained to achieve desired results.

Smiths Interconnect makes no warranties as to the accuracy or completeness of the information, and disclaims any liability regarding its use.

Smiths Interconnect reserves the right to modify design and specifications, in order to improve quality, keep pace with technological development, or meet specific production requirements.

Reproduction or use of editorial and/or pictorial content in any manner, without express written permission, is prohibited.

Worldwide Support

Connectors

Americas

Sales

connectors.uscsr@smithsinterconnect.com

Technical Support

connectors.ustechsupport@smithsinterconnect.com

Europe

Sales

connectors.emeacsr@smithsinterconnect.com

Technical Support

connectors.emeatechsupport@smithsinterconnect.com

Asia

Sales

asiacsr@smithsinterconnect.com

Technical Support

asiatechsupport@smithsinterconnect.com

Fibre Optics & RF Components

Americas

Sales

focom.uscsr@smithsinterconnect.com

Technical Support

focom.techsupport@smithsinterconnect.com

Europe

Sales

focom.emeacsr@smithsinterconnect.com

Technical Support

focom.techsupport@smithsinterconnect.com

Asia

Sales

focom.asiacsr@smithsinterconnect.com

Technical Support

focom.techsupport@smithsinterconnect.com

Semiconductor Test

Americas

Sales

semi.uscsr@smithsinterconnect.com

Technical Support

semi.techsupport@smithsinterconnect.com

Europe

Sales

semi.emeacsr@smithsinterconnect.com

Technical Support

semi.techsupport@smithsinterconnect.com

Asia

Sales

semi.asiacsr@smithsinterconnect.com

Technical Support

semi.techsupport@smithsinterconnect.com

RF/MW Subsystems

Americas, Europe & Asia

Sales

subsystems.csr@smithsinterconnect.com

Technical Support

subsystems.techsupport@smithsinterconnect.com

Connecting Global Markets

more > [smithsinterconnect.com](https://www.smithsinterconnect.com)

