

ORDERING INFORMATION

PART IDENTIFIER: P2S35D



SPECIFICATIONS

1. ELECTRICAL:

Frequency	Isolation	Insertion Loss	Amplitude Balance	Phase Balance	Power Handling
0.8 – 1.0 GHz	16 dB Min	0.3 dB Max	±0.2 dB	±2° Max	35 Watts

VSWR: PORT 1 1.40:1 Max
 PORT 2,3 1.30:1 Max

2. ENVIRONMENTAL:

Operating Temperature: -55°C to +150°C

3. MARKING:

HybriX and part number

4. QUALITY ASSURANCE:

Sample Inspect Per MIL-STD-105, Level II, 1.0% AQL.

Visual and Mechanical Examination for Conformance to Outline Drawing Requirements.

Measure Amplitude Balance and VSWR

Test Data Requirements

No Test Data Required

Data Retention – 12 months

5. PACKAGING:

Standard Packaging: Tube

Note: Specifications are subject to change.

6. MECHANICAL:

Substrate Material: Alumina
 Resistive Film: Thick film
 Terminal Material: Thick film, Nickel barrier solder plated
 Metric Dimensions: Provided for reference only

POWER DIVIDER 2 WAY 35 WATT

DATASHEET

PART SERIES: P2S35D

Sheet 2 of 2
Doc# P2S35D

ECO-081747
Revision A

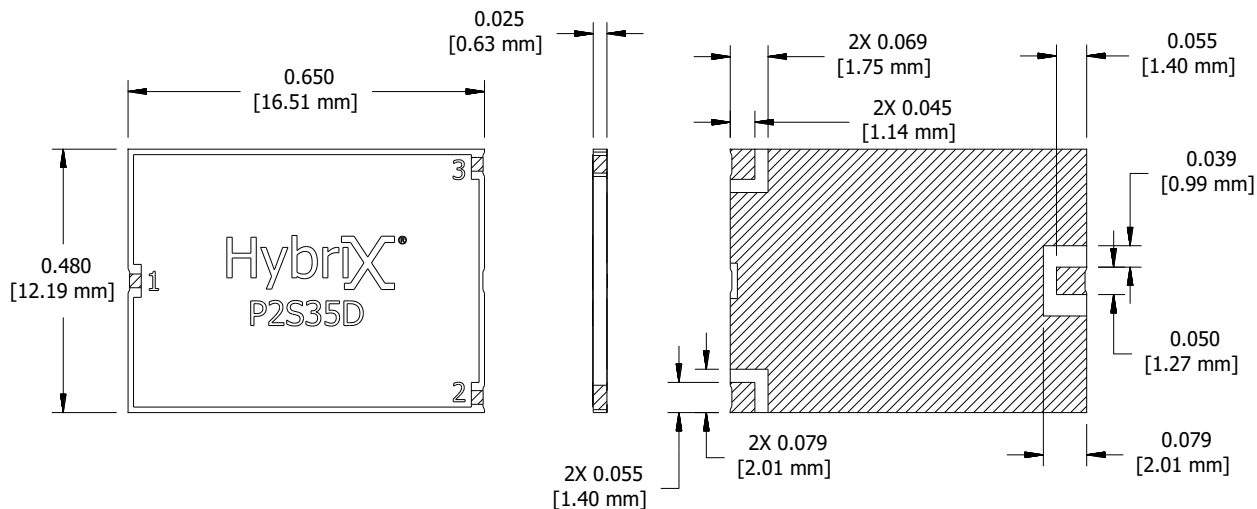

Unless Otherwise Specified: TOLERANCE: X.XX = ± 0.02 X.XXX = ± 0.010

Note: Specifications are subject to change.