

TITLE: SPECIFICATION CONTROL DRAWING

PART IDENTIFIER: TT3XXXW3

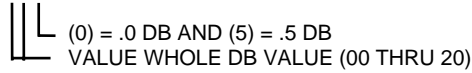

DESCRIPTION: CHIP ATTENUATOR

ASSEMBLY DWG: 1902044

1.0 SPECIFICATIONS:

1.1 ELECTRICAL:

- 1.1.1 IMPEDANCE: 50 OHMS NOMINAL.
- 1.1.2 FREQUENCY RANGE: DC-8 GHZ.
- 1.1.3 ATTENUATION VALUES AVAILABLE: 0-20 DB IN .5 DB INCREMENTS.
- 1.1.4 ATTENUATION ACCURACY: SEE TABLE.

ATTENUATION ACCURACY		
DB	DC - 4 GHZ	4 - 8 GHZ
0	-0,+0.3	-0,+0.5
.5 - 3	±0.3	±0.5
3.5 - 6	±0.4	±0.5
6.5 - 10	±0.5	±0.5
10.5 - 15	±0.75	+0.5,-3.0
15.5 - 20	±1.0	+0.5,-4.0

- 1.1.5 VSWR: DC - 4 GHZ - 1.25.
4 - 8 GHZ - 1.35.
- 1.1.6 INPUT POWER: 2 WATTS CW.
 - 1.1.6.1 FULL RATED POWER TO 125°C, DERATED LINEARLY TO 0 WATTS AT 150°C.
 - 1.1.6.2 PEAK POWER, 50 WATTS FOR 10US PULSE WIDTH @ 1% DUTY CYCLE.
- 1.2 MECHANICAL:
 - 1.2.1 OUTLINE DWG: SEE SHEET 2.
 - 1.2.2 WORKMANSHIP: PER MIL-PRF-55342.
- 1.3 ENVIRONMENTAL:
 - 1.3.1 ALTITUDE:
 - 1.3.1.1 NON-OPERATING: SEA LEVEL TO 50,000 FEET.
 - 1.3.1.2 OPERATING: SEA LEVEL TO 50,000 FEET.
 - 1.3.2 TEMPERATURE RANGE:
 - 1.3.2.1 NON-OPERATING: -55 C TO +150 C.
 - 1.3.2.2 OPERATING: -55°C TO +150°C.
 - 1.3.3 VIBRATION: PER MIL-STD-202, METHOD 204, COND. D.
 - 1.3.4 SHOCK: PER MIL-STD-202, METHOD 213, COND. I.
 - 1.3.5 MOISTURE RESISTANCE: PER MIL-STD-202, METHOD 106 EXCEPT SUBCYCLE STEPS 7A AND 7B AND POLARIZATION AND LOAD ARE NOT APPLICABLE.

2.0 UNIT MARKING: "DB VALUE". GREEN DOT ADDS 0.5DB. LEGIBILITY AND PERMANENCY PER MIL-STD-130.

3.0 QUALITY ASSURANCE:

- 3.1 SAMPLE INSPECT PER ANSI/ASQC Z1.4 GENERAL INSPECTION, LEVEL II, AQL = 1.0.
 - 3.1.1 VISUAL AND MECHANICAL EXAMINATION FOR CONFORMANCE TO OUTLINE DWG REQUIREMENTS.
- 3.2 PERFORM INSPECTION IN ACCORDANCE WITH QA0006 AND FORM0357 FOR COMMERCIAL GRADE PRODUCT.
- 3.3 TEST DATA REQUIREMENTS:
 - 3.3.1 NO TEST DATA REQUIRED FOR CUSTOMER.
 - 3.3.2 DATA RETENTION – 24 MONTHS.

4.0 PACKAGING: STANDARD PACK PER MC0023.

EMC TECHNOLOGY 8851 SW OLD KANSAS AVE. STUART, FL 34997	CAGE CODE # 24602		DWG #	1011455000
	CHANGE NOTICE	EN 07-E0452	REV LVL	-
			SHEET	1 OF 2

PART ID REF

TT3XXXW3

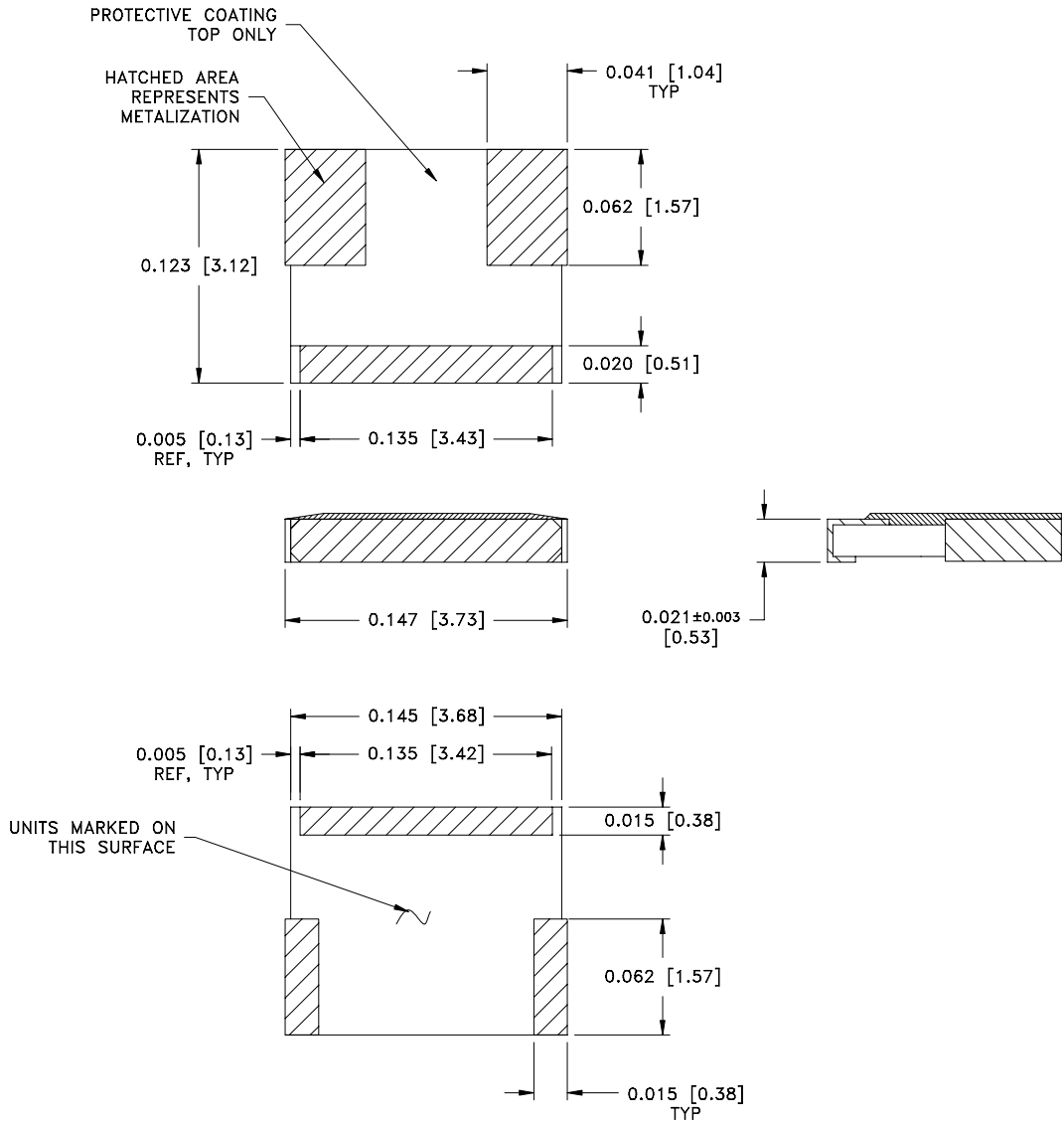

MECHANICAL SPECIFICATIONS:

SUBSTRATE:
 MATERIAL - ALUMINA, MIL-I-10.
 TERMINAL:
 MATERIAL - THICK FILM, NICKEL BARRIER,
 SOLDER PLATED.
 RESISTIVE ELEMENT:
 MATERIAL - THIN FILM TANTALUM NITRIDE.

METRIC EQUIVALENTS GIVEN IN [mm]
 FOR REFERENCE INFORMATION ONLY



POWER RATING AND DERATING

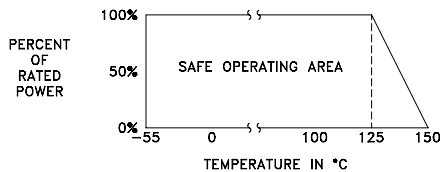

 8851 SW OLD KANSAS AVE STUART, FL 34997 PHONE NO. (772)286-9300 FAX NO. (772)283-5286	UNLESS OTHERWISE SPECIFIED DIMENSIONS ARE IN INCHES TOLERANCES FRACT --- ANG --- XX --- XXX ±0.005 XXXX ---	THESE DRAWINGS AND SPECIFICATIONS ARE THE PROPERTY OF EMC TECHNOLOGY INC AND SHALL NOT BE DUPLICATED OR USED AS BASIS FOR THE MANUFACTURE OR SALE OF PARTS OR DEVICES WITHOUT PERMISSION.					
		CAGE CODE 24602	SCALE 16:1	DRAWN BY CRH 05/02/07	CHECKED BY	APPROVED BY	
	REV -	CHANGE NOTICE EN 07-E0452	DRAWING NO 1011455000	SHEET 2 OF 2			