

TITLE: SPECIFICATION CONTROL DRAWING

PART IDENTIFIER: 8431

DESCRIPTION: 50 OHM FLANGE LOAD

ASSEMBLY DWG: 2100004

1.0 SPECIFICATIONS:

1.1 ELECTRICAL:

- 1.1.1 IMPEDANCE: 50 OHMS NOMINAL.
- 1.1.2 FREQUENCY RANGE: DC-18 GHZ.
- 1.1.3 INPUT POWER (MAX @ 60°C): (DERATED LINEARLY TO ZERO POWER @ 150°C)
 - 1.1.3.1 AVERAGE: 1 WATT.
 - 1.1.3.2 PEAK: 100 WATTS (100 US PULSE WIDTH AND 0.1% DUTY CYCLE).
- 1.1.4 VSWR:
 - DC TO 4.0 GHZ - 1.10 MAX.
 - 4.0 TO 8.0 GHZ - 1.15 MAX.
 - 8.0 TO 12.0 GHZ - 1.20 MAX.
 - 12.0 TO 18.0 GHZ - 1.30 MAX.

1.2 MECHANICAL:

- 1.2.1 OUTLINE DWG: SEE SHEET 2.

1.3 ENVIRONMENTAL:

- 1.3.1 TEMPERATURE RANGE:
 - 1.3.1.1 NON-OPERATING: -55°C TO +150°C.
 - 1.3.1.2 OPERATING: -55°C TO +150°C.
- 1.3.2 VIBRATION: PER MIL-STD-202, METHOD 201 AND MIL-D-39030.
- 1.3.3 SHOCK: PER MIL-STD-202, METHOD 213, COND. I.
- 1.3.4 MOISTURE: PER MIL-STD-202, METHOD 106 AND MIL-D-39030 EXCEPT LOADING VOLTAGE IS NOT APPLICABLE.

2.0 UNIT MARKING: "EMCT"

LEGIBILITY AND PERMANENCY PER MIL-STD-130.

3.0 QUALITY ASSURANCE:

- 3.1 PERFORM INSPECTION IN ACCORDANCE WITH QA0006 AND FORM0357 FOR COMMERCIAL GRADE PRODUCT.
- 3.2 TEST DATA REQUIREMENTS:
 - 3.2.1 NO TEST DATA REQUIRED FOR CUSTOMER.
 - 3.2.2 DATA RETENTION – 24 MONTHS.

4.0 PACKAGING: STANDARD PACK PER MC0023.

ENG		PUR		MFG		PLAN		SM		
CC				QA						
EMC TECHNOLOGY, INC 1971 OLD CUTHBERT ROAD CHERRY HILL, NJ 08034		CAGE CODE # 24602					DWG #	1000175000		
		CHANGE NOTICE	EM 01-305				REV LVL	E		
							SHEET	1 OF 2		

PART ID REF

8431

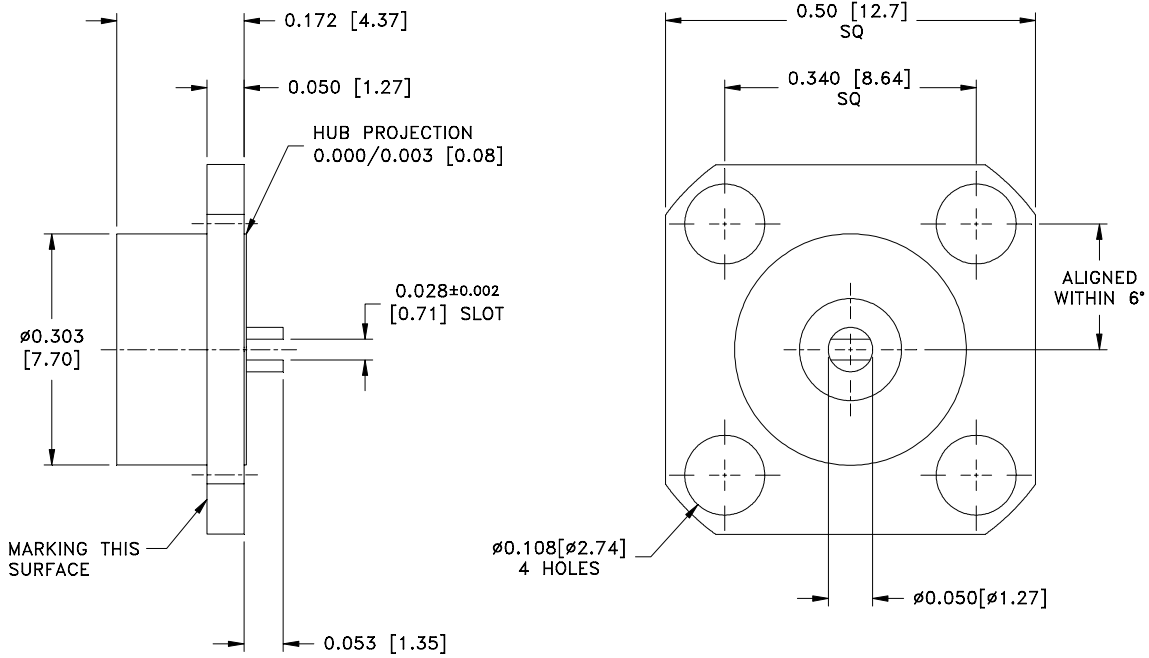

MECHANICAL SPECIFICATIONS:

FLANGE FACE CASE:

MATERIAL - ALUMINUM ALLOY, QQ-A-250.
FINISH - CHROMATE, MIL-C-5541.

FLANGE HUB:

MATERIAL - ALUMINUM ALLOY, QQ-A-225.
FINISH - CHROMATE, MIL-C-5541.

PIN:

MATERIAL - BERYLLIUM COPPER, ASTM B197.
FINISH - GOLD, MIL-G-45204, TYPE II, CLASS 1.

DIELECTRIC:

MATERIAL - TEFLON, ASTM D1710.

CERAMIC:

MATERIAL - ALUMINA, MIL-I-10.

METRIC EQUIVALENTS GIVEN IN [mm]
FOR REFERENCE INFORMATION ONLY

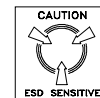

POWER RATING AND DERATING

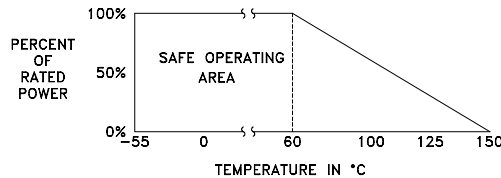

EMC TECHNOLOGY INC
1971 OLD CUTHBERT RD
CHERRY HILL NJ 08034
PHONE NO. (856) 429-7800
FAX NO. (856) 429-1807

UNLESS OTHERWISE SPECIFIED DIMENSIONS ARE IN INCHES TOLERANCES
FRACT --- --
ANG --- --
XX ±0.01
XXX ±0.005
XXXX --- --

THESE DRAWINGS AND SPECIFICATIONS ARE THE PROPERTY OF EMC TECHNOLOGY INC AND SHALL NOT BE DUPLICATED OR USED AS BASIS FOR THE MANUFACTURE OR SALE OF PARTS OR DEVICES WITHOUT PERMISSION.

CAGE CODE 24602	SCALE 1:1	DRAWN BY CME 08/15/2001	CHECKED BY	APPROVED BY DAR 8/21/01
REV E	CHANGE NOTICE EN 01-305	DRAWING NO 1000175000	SHEET 2 OF 2	