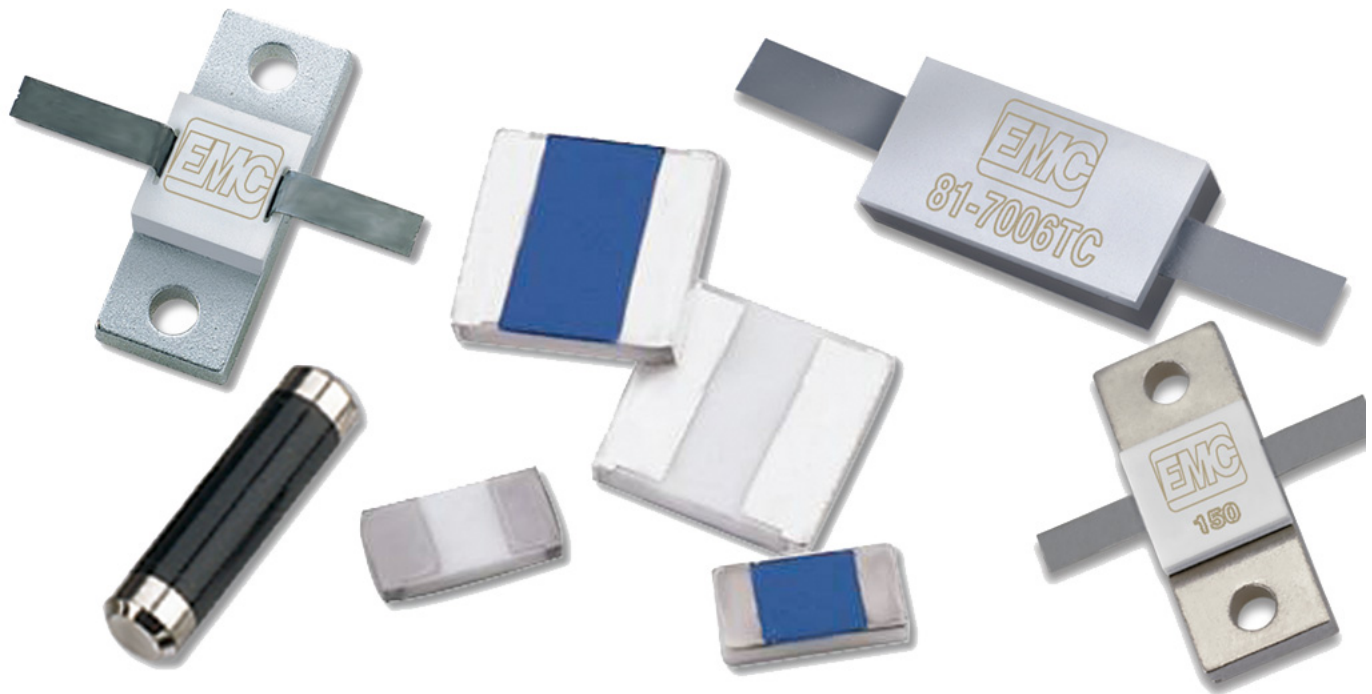


# MICROWAVE COMPONENTS





# About Smith Interconnect

Smiths Interconnect is a leading provider of technically differentiated electronic components, subsystems, microwave and radio frequency products that connect, protect and control critical applications in the Defence and Aerospace, Communications and Industrial markets.

Our technology brands (EMC, Hypertac, IDI, Lorch, Millitech, Reflex Photonics, RF Labs, Sabritec, TECOM, TRAK and HSI) are synonymous with exceptional performance in technologically advanced, high quality solutions required for a high degree of safety and durability. Our extensive product portfolio includes high reliability electrical connectors and cable assemblies, solutions for antenna systems, and a wide range of innovative RF and microwave solutions.

Smiths Interconnect is part of Smiths Group plc, a global leader in applying advanced technologies for markets in threat and contraband detection, energy, medical devices, communications and engineered components. Smiths Group employs around 22,000 people in more than 50 countries.

Your global partner  
for innovative  
connectivity  
solutions

INDUSTRIAL



COMMUNICATIONS



DEFENCE  
& AEROSPACE



## We Offer

Technical excellence and broad market experience

A comprehensive product portfolio providing customers with a single point of supply across multiple markets

Advanced engineered solutions integrating the combined expertise of our technology brands to create value for our customers

Optimised quality through first-class materials, state-of-the-art development practices, and world class talent

Robust financial pedigree and reputable heritage of Smiths Group

# Technology Brands

EMC



## High Reliability RF/Microwave Resistive & Signal Distribution Components

Board-level components incorporating advanced resistive and signal distribution technologies for a broad range of frequency spectrum applications. Extensive portfolio of RF devices used to attenuate, level, or terminate signals available in a variety of packages and footprints.

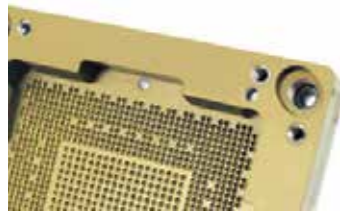
HYPERTAC



## Superior Performing Electrical Connectors for the Most Demanding Applications

Premium interconnect solutions for electrical and electronic applications requiring optimised quality, performance, and reliability. Utilising the original Hypertac hyperboloid contact technology to achieve high performance in harsh environments and safety critical applications.

IDI



## High Density Interconnect & Semiconductor Test Solutions with Spring Probe Technology

World's most comprehensive offering of spring probe based solutions, including: contacts, connectors, interposers, semiconductor test sockets, and ATE interfaces. Proven off-the-shelf and custom products deliver the best solution for the customer's specific application.

LORCH



## RF/Microwave Conditioning Products with High Selectivity Using Multiple Topologies

Innovative solutions for the electronics and communications industries. Ranging from high performance wireless and RF products to micro-miniature, cavity, discrete, waveguide, tunable, ceramic, and tubular filters and integrated assemblies.

MILLITECH



## Leader in Millimeter-Wave Technology & Product Solutions

Specialising in the engineering, manufacturing, and testing of millimeter-wave components, assemblies, and fully integrated subsystems for space, SATCOM, test and measurement, radar, and scientific applications.

REFLEX  
PHOTONICS



## Developer of Rugged, High Speed Optical Transceiver Modules & Parallel Embedded Optics Products

Embedded transceivers and transmit/receive modules for advanced interconnect-based solutions. Targeting high data rate interconnects where ruggedness and radiation resistance are required for defence, space, commercial aerospace and industrial applications.

## RF LABS



### High Frequency Microwave Cable Assemblies & Coaxial Components

High performance microwave cable assemblies and coaxial components supporting high performance operations, application-specific premium interconnects for high durability and harsh environments.

## SABRITEC



### High Speed Data and Transient Protection Interconnect Solutions

High speed quadrate, twinax, fibre optic, filter, coax and triax connectors, contacts and cable assemblies. Custom multi-pin circular, D-Sub rack and panel connectors and MIL-Spec interface type products.

## TECOM



### Advanced Antenna Systems & Solutions for RF/Microwave Applications

Industry leading innovator of antennas and positioning systems for SATCOM in-flight connectivity, instrumentation, datalink, command & control, and telemetry applications integrated into the world's most advanced commercial and military platforms.

## TRAK



### High Reliability RF/Microwave Subsystems & Components

High reliability multi-function RF systems, ferrite microwave products, and precision time & frequency systems for defence, commercial aerospace, space, homeland security, and public safety applications.

## HSI



### High Reliability Connectors for Commercial Aerospace & Railway

Joint venture with Sichuan Huafeng Enterprise Group Co. Ltd, one of the major manufacturers of electronic components in China. Industry-leading connectivity solutions for commercial aerospace and railway markets in mainland China.

Synonymous with exceptional performance,  
safety and durability

# Table of Contents

## Microwave Components



### Thermopad® Temperature Variable Attenuators ..... 1-16

Thermopad® Family .....	Introduction	1
Thermopad® Family .....	General Specifications	2-4
Standard .....	TVA	5
Standard Miniature .....	MTVA	6
Wide Band .....	WTVA	7
K-Band .....	KTVA	8
Q-Band .....	QTVA	9
AN Series .....	AN11, AN7, AN5, AN3	10-11
Broadband and Cable .....	CTVA	12
Extended Shift .....	ETVA	13
Coaxial .....	Specialty	14
High Reliability .....	HRT	15
High Reliability Miniature .....	HRM	16



### Fixed Attenuators .....17-36

Fixed Attenuator Family .....	Introduction	17
Chip .....	TS03, TS05	18-19
K-Band .....	KFA	20
Q-Band .....	QFA	21
Chip .....	TS09, TS04, TS07, TS06	22-24
High Power Chip .....	HPCA	25
SMT Chip .....	83 Series Chip	26-27
Power Pack .....	83 Series Tab & Cover	28-30
High Power .....	33 Series Flange	31-33
High Reliability Chip .....	HR05, HR03	34-35
Coaxial SMA .....	42 Series	36



### Terminations ..... 37-54

Termination Family .....	Introduction	37
SMT Series .....	Surface Mount	38-39
CT Chip .....	High Power Series	40-41
82 Series .....	Tab & Cover	42-43
32 & 5 Series .....	Flange	44-49
Stripline Flange Series .....	Flange	50-52
12 & 41 Series .....	Coaxial	53-54



### Resistors .....55-64

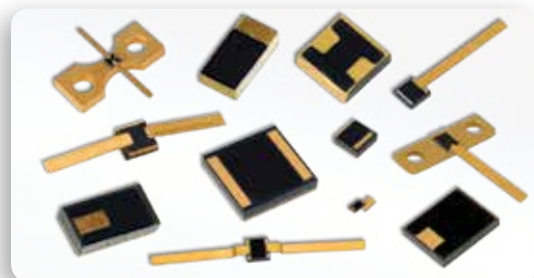
Resistor Family .....	Introduction	55
Chip .....	Surface Mount	56-57
81 Series .....	Tab & Cover	58-59
Flange .....		60-62
Rod .....		63
Notes .....		64

# Table of Contents

## Microwave Components

### Diamond Rf Resistives® ..... 65-74

Diamond Rf Resistives® .....	65
Chip Attenuator .....	66
Tabbed Attenuator .....	67
Flange Attenuator .....	68
Chip Resistor .....	69-71
Tabbed SMT Chip Resistor .....	71
Chip Termination .....	72-73
Flange & Tab Termination .....	74



### HybriX® Couplers & Signal Distribution ..... 75-88

HybriX® Hybrid Couplers .....	75-78
HybriX® Directional Couplers .....	79-83
SMT Crossovers .....	84
Power Dividers .....	85-86
Resistive Power Dividers .....	87
Power Samplers .....	88



### Innovative Solutions ..... 89-94

Innovative Solutions .....	89
Low PIM .....	90
Non-Magnetic .....	91-92
Thermal Management .....	93-94



### Legacy ..... 95-100

Legacy Product Family .....	95
Switch Termination .....	96
Coaxial Remote Termination .....	97
Pill Termination .....	98
Film Cards .....	99
Notes .....	100



### Appendix ..... 101-104

Standard High Reliability Test Flow .....	101
Engineering Design and Product Kits .....	102
Cable Assembly Solutions .....	103
Smiths Interconnect Companies .....	104

### Index ..... 105-106





### Features

- Frequency Ranges from DC to 50 GHz
- Attenuation Values from 1 to 10 dB
- Negative and Positive Temperature Coefficients of Attenuation (TCA) Available
- Power Handling Up to 2 Watts
- Space and Military Qualified
- Surface Mount Packaging
- Wire Bondable Connections Available
- Impedance 50 and 75 Ohms
- RoHS Compliant Option Available

### Benefits

- Small Footprint
- Zero Distortion
- Totally Passive
- Power Handling up to 2 Watts
- Several Metallization Options Available
- Tailored Response to Variations Over Temperature
- Requires no DC power.

### Applications

- Power Amplifiers
- Military
- Mixers
- Satellite Communication
- Gain Blocks
- MMIC Amplifiers
- Directional Couplers
- Diode Detectors
- Broadcast (TV and Radio)



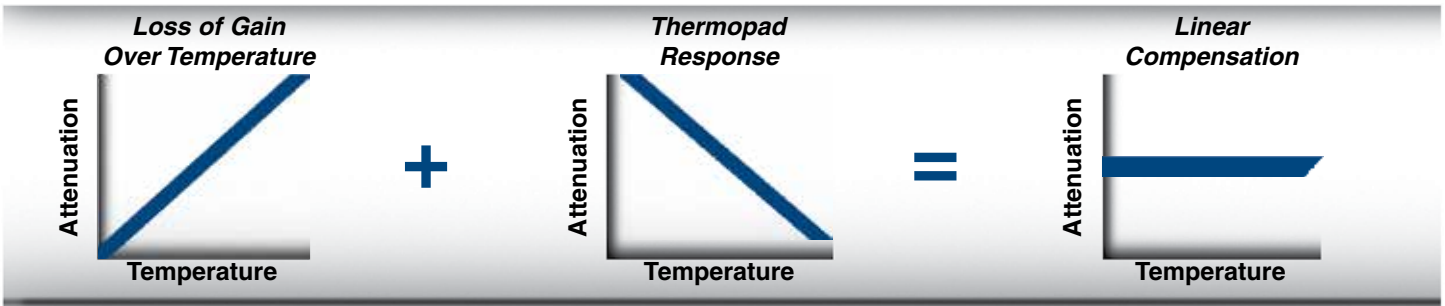
The Thermopad® is a totally passive, surface mountable temperature variable attenuator. It requires no bias or control voltages and does not generate signal distortion. The Thermopad can be used in place of a standard chip attenuator to combine level setting and temperature compensation in a single chip design. This will reduce component count, increase reliability, and lower system costs.

### Quick Selector Chart

Series	Frequency (GHz)	Power (Watts)	Footprint mm [inches]		Page
TVA	DC - 6	2.0	3.68 x 3.10	[0.145 x 0.122]	5
MTVA	DC - 18	0.2	1.90 x 1.52	[0.075 x 0.060]	6
WTVA	DC - 20	0.2	1.78 x 1.52	[0.070 x 0.060]	7
KTVA	16 - 36	0.1	3.05 x 1.65	[0.120 x 0.065]	8
QTVA	36 - 50	0.1	3.05 x 1.65	[0.120 x 0.065]	9
AN3	DC - 4	2.0	3.68 x 3.10	[0.145 x 0.122]	11
AN5	DC - 6	0.2	1.90 x 1.52	[0.075 x 0.060]	10
AN7	DC - 6	0.1	2.03 x 1.27	[0.080 x 0.050]	10
AN11	DC - 6	0.1	1.14 x 0.64	[0.045 x 0.025]	10
ETVA	DC - 3	2.0	4.06 x 3.68	[0.160 x 0.145]	13
CTVA (75Ω)	DC - 2	2.0	3.68 x 3.10	[0.145 x 0.122]	12
Coax TVA	DC - 6	2.0	7.92 x 19.05	[0.312 x 0.750]	14
HRTVA	DC - 6	2.0	3.68 x 3.10	[0.145 x 0.122]	15
HRMTVA	DC - 18	0.2	1.91 x 1.52	[0.075 x 0.060]	16

# Thermopad® Family

## General Specifications



- Small Footprint
- Surface Mountable
- Contributes No Signal Distortion
- Totally Passive
- Power Handling up to 2 Watts
- Several Metallization and Packaging Options Available
- Tailored Response to Cancel Amplifier Gain Variations Over Temperature
- Requires no DC Power

The Thermopad® is a totally passive absorptive microwave attenuator, which provides power dissipation that varies with temperature. The device can be used in any application that requires a known amount of attenuation change for a particular temperature shift. This is particularly useful for preventing gain loss over temperature in various amplifier applications.

In applications from DC - 50 GHz, EMC's Thermopad is the ideal temperature compensation solution for cost, size, performance, and reliability. The Thermopad can replace closed loop temperature compensation circuits with a single chip device requiring no bias or active control. Since the Thermopad produces no signal distortion it excels in applications involving multiple tones and complex modulation schemes such as cellular base station applications and radar. In high reliability, military, and spacecraft applications the Thermopad reduces system complexity and cost.

## Thermopad® Selector Tool

Print Downloads Help

Start Here! Enter your Product(s) Attenuation Tasks

Thermopad® Selector  
UP AUTO RESET

MTVA0200N05  
MTVA0200N06  
MTVA0200N07  
MTVA0300N03  
MTVA0300N04  
MTVA0300N05  
MTVA0300N06  
MTVA0300N07

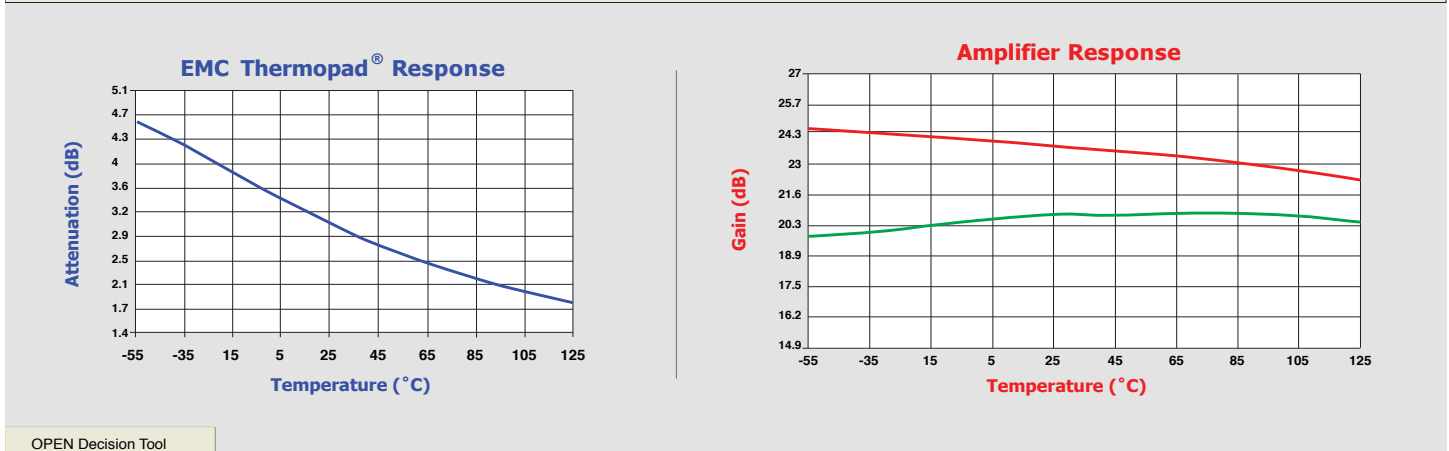
Temp °C	Amplifier Gain (dB)	Thermopad Attn (dB)	Compensated Attn (dB)
-55	24.60	4.67	19.93
-55	24.40	4.31	20.09
-15	24.25	3.9	20.35
5	24.10	3.46	20.54
25	23.98	3.09	20.79
45	23.60	2.77	20.83
65	23.40	2.49	20.91
85	23.15	2.25	20.9
105	22.80	2.04	20.76
125	22.40	1.88	20.52

NOW VIEWING: MTVA0300N05

Application Notes  
View Product PDF  
Print Chart  
Request Quote

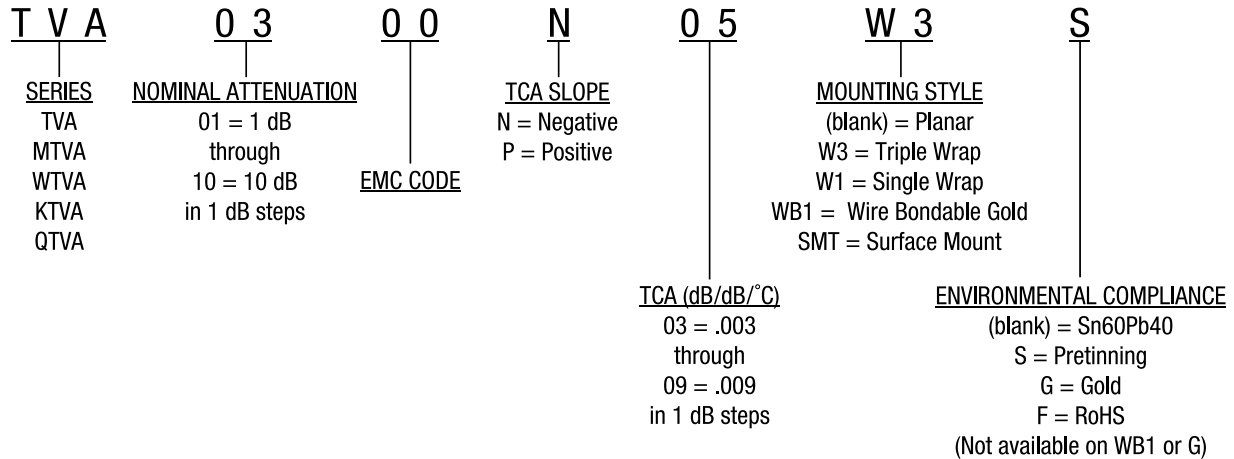
**EMC Technology**  
8851 S.W. Old Kansas Ave.  
Stuart, FL 34997

Step 1: Select a Product    Step 2: Modify Amplifier Gain (dB)    Step 3: Common Tasks



OPEN Decision Tool

### Part Numbering Code



Note: Not every combination of attenuation and TCA values are available.

### Mounting Style Options

**Planar (no code)** Planar device for flip chip mounting offers the best RF performance and lowest cost.

**Triple Wrap (W3)** Metallization wraps around input, output, and ground terminals. Permits inspectable solder fillets when flip chip mounting.

**Surface Mount (SMT)** Metallization wraps around input, output, and ground terminals. For a true surface mount technology. (WTVA and TS09 series only). Or flip chip surface mount. (KFA, KTVA, QFA and QTVA).

**Single Wrap (W1)** Metallization wraps around ground terminal only. Full backside metallization.

**Single Wrap (WB1)** Metallization wraps around ground terminal only. Full backside metallization. Input and output terminals have gold metallization for wire bonding (MTVA series only).

**Double Wrap (WB2)** Metallization wraps around ground terminal only on 2 sides. Full backside metallization. Input and output terminals have gold metallization for wire bonding (WTVA and TS09 series only).

### Environmental Compliance Options

**Standard (no code)** Plated (with Sn60Pb40 solder) improves solderability (available on all of the above options except Option G and KTVA).

**Pretinned (S)** Pretinning (with Sn60Pb40 solder) improves solderability (available on all of the above options except Option G and KTVA).

**RoHS (F)** RoHS compliant option (excludes WB1, G, and S metallization options).

**Gold (G)** Planar device with gold metallization. Typically used for wire bonding (TVA, MTVA and HTVA series only).

**Note:** KTVA bondable unit backside ground metallization is platinum silver. Input and output terminals have gold metallization for wire bonding.

### Attenuator Selector Chart

FOOT PRINT	1512 3.68 X 3.10mm [0.145 x 0.122]	1615 4.06 X 3.68mm [0.160 x 0.145]	0706 1.78 X 1.52mm [0.070 x 0.060]	0805 2.03 X 1.27mm [0.080 x 0.050]	0806 1.91 X 1.52 mm [0.075 x 0.060]	1206 3.05 X 1.65mm [0.120 x 0.065]
THERMOPAD®	TVA	ETVA	WTVA	AN7	MTVA/AN5	KTVA/QTVA
FIXED	TS03	TS03	TS09	TS07	TS05	KFA/QFA

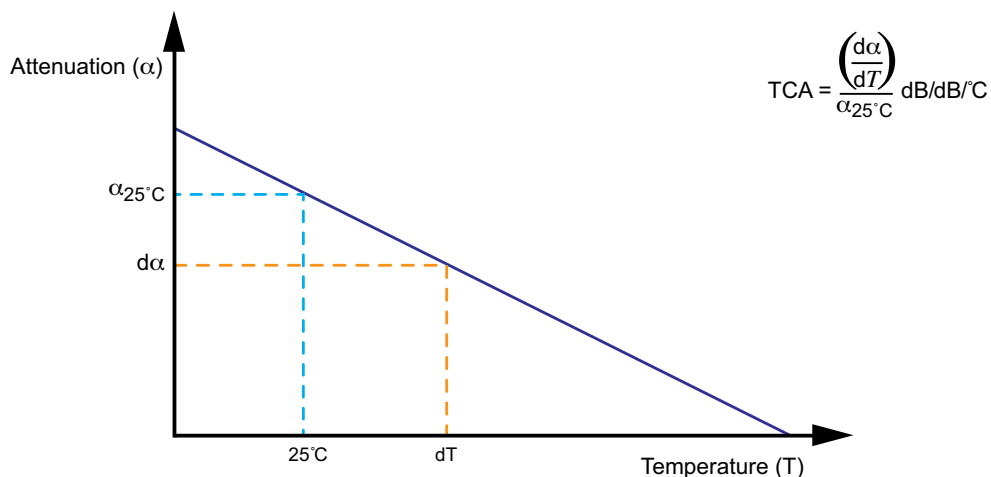
# Thermopad® Family

## General Specifications

### Thermopad® Temperature Shift Reference Chart (Attenuation Shift in dB per 10°C)

	TCA* dB/dB/ °C	Attenuation at 25°C										
		1 dB	2 dB	3 dB	4 dB	5 dB	6 dB	7 dB	8 dB	9 dB	10 dB	
Negative Temperature Compensation	-0.003	-0.03	-0.06	-0.09	-0.12	-0.15	-0.18	-0.21	-0.24	-0.27	-0.30	
	-0.004	-0.04	-0.08	-0.12	-0.16	-0.20	-0.24	-0.28	-0.32	-0.36	-0.40	
	-0.005	-0.05	-0.10	-0.15	-0.20	-0.25	-0.30	-0.35	-0.40	-0.45	-0.50	
	-0.006	-0.06	-0.12	-0.18	-0.24	-0.30	-0.36	-0.42	-0.48	-0.54	-0.60	
	-0.007	-0.07	-0.14	-0.21	-0.28	-0.35	-0.42	-0.49	-0.56	-0.63	-0.70	
	-0.009	-0.09	-0.18	-0.27	-0.36	-0.45	-0.54	-0.63	-0.72	-0.81	-0.90	
	-0.010	-0.10	-0.20	-0.30	-0.40	-0.50	-0.60	For configurations not listed please contact our Sales Department				
	-0.011	-0.11	-0.22	-0.33	-0.44	-0.55	-0.66					
	-0.012	-0.12	-0.24	-0.36	-0.48	-0.60	-0.72					
	-0.013	-0.13	-0.26	-0.39	-0.52	-0.65	-0.78					
	-0.014	-0.14	-0.28	-0.42	-0.56	-0.70	-0.84					
	-0.015	-0.15	-0.30	-0.45	-0.60	-0.75	-0.90					
	-0.016	-0.16	-0.32	-0.48	-0.64	-0.80	-0.96					
Positive Temperature Compensation	0.003	0.03	0.06	0.09	0.12	0.15	0.18					
	0.005	0.05	0.10	0.15	0.20	0.25	0.30					
	0.006	0.06	0.12	0.18	0.24	0.30	0.36					
	0.007	0.07	0.14	0.21	0.28	0.35	0.42					
	0.008	0.08	0.16	0.24	0.32	0.40	0.48					
	0.009	0.09	0.18	0.27	0.36	0.45	0.54					

\*TCA is temperature coefficient of attenuation and is calculated using the following equation:

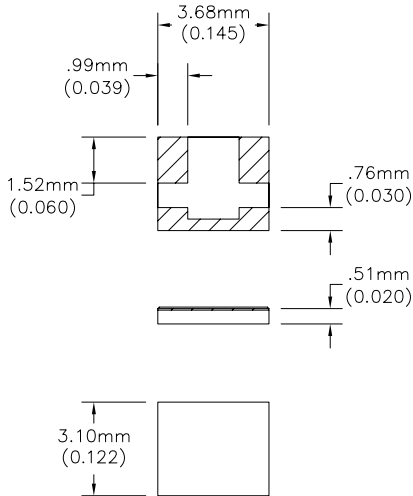




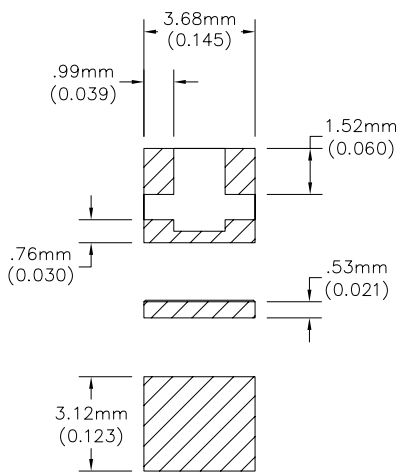
# TVA (6.0 GHz)

Thermopad®

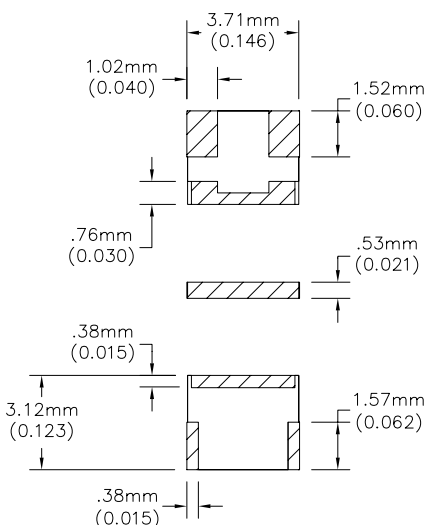
## TVA Planar Series



## TVA Single Wrap Series



## TVA Triple Wrap Series

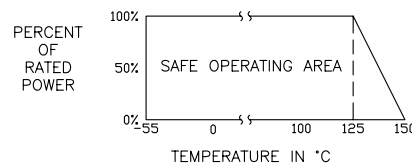


EMC Technology's TVA Thermopad®s are microwave absorptive attenuators which provide power dissipation that varies with temperature and operate in frequency ranges from DC to 6 GHz. This surface mount, temperature variable attenuator requires no bias or control voltages and generates zero distortion. This product is available with various metallization styles and plating options including gold for wire bonding applications, RoHS compliant lead free silver over nickel plating, 60/40 low temperature solder plating or 60/40 solder fused finish for easy reflow processing. It is available in both negative and positive shifting temperature slopes.

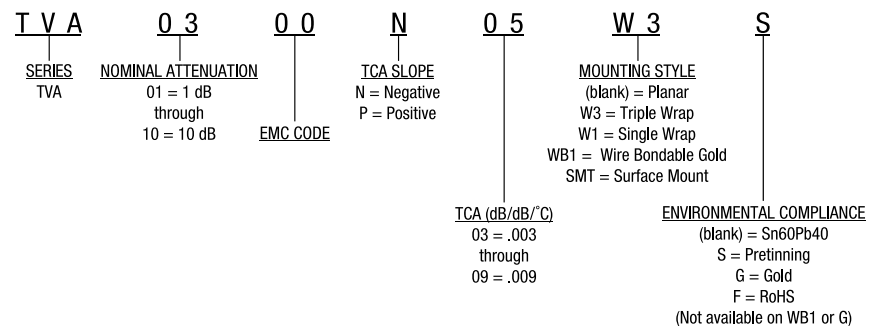
## Specifications

Size	3.10mm x 3.68mm [0.122in x 0.145in]
Impedance	50 Ohms
Frequency Range	DC to 6 GHz
TCA Tolerance	±0.001 dB/dB/°C
VSWR (Typical)	1.30 @ 1 GHz
Power Rating	2.0 Watts
Operating Temperature	-55°C to 150°C
Substrate	Alumina
Resistive Material	Thick Film
Terminal Material	Thick Film, Nickel Barrier with Solder Plate or Lead Free Finish Gold and Wire Bondable Options Available

## Power Rating and Derating

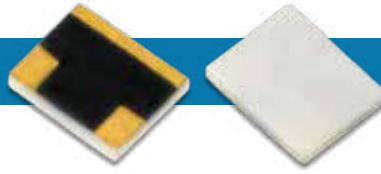


## Part Numbering Code



# MTVA (18.0 GHz)

## Mini Thermopad®

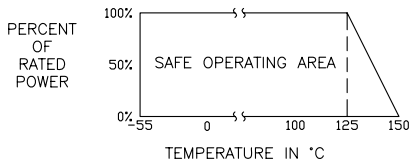


EMC Technology's MTVA Thermopad®s are microwave absorptive attenuators which offer a smaller physical size with increased frequency range. The series operates DC to 18 GHz. The MTVA version of the Thermopad also offers wire bondable terminals for use with alternative high frequency attachment methods and space applications. This product is available with various metallization styles and plating options including RoHS compliant lead free silver over nickel plating, 60/40 low temperature solder plating or 60/40 solder fused finish for easy reflow processing

### Specifications

Size	1.52mm x 1.91mm [0.060in x 0.075in]
Impedance	50 Ohms
Frequency Range	Planar DC to 18 GHz W Series DC to 12.4 GHz
TCA Tolerance	±0.001 dB/dB/°C
VSWR (Typical)	1.30 @ 1 GHz
Power Rating	200 Milliwatts
Operating Temperature	-55°C to 150°C
Substrate	Alumina
Resistive Material	Thick Film
Terminal Material	Thick Film, Nickel Barrier with Solder Plate or Lead Free Finish Gold and Wire Bondable Options Available

### Power Rating and Derating



### Part Numbering Code

**MTVA**    **03**    **00**    **N**    **05**    **W3**    **S**

**SERIES**  
MTVA

**NOMINAL ATTENUATION**  
01 = 1 dB through  
09 = 9 dB

**EMC CODE**

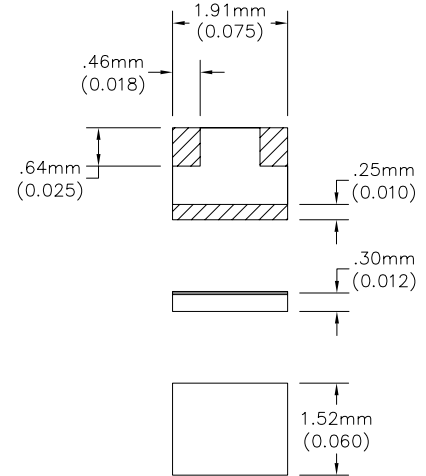
**TCA SLOPE**  
N = Negative  
P = Positive

**TCA (dB/dB/°C)**  
03 = .003 through  
09 = .009

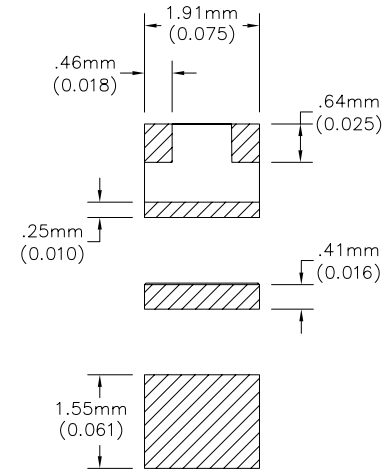
**MOUNTING STYLE**  
(blank) = Planar  
W3 = Triple Wrap  
W1 = Single Wrap  
WB1 = Wire Bondable Gold

**ENVIRONMENTAL COMPLIANCE**  
(blank) = Sn60Pb40  
S = Pretinning  
G = Gold  
F = RoHS  
(Not available on WB1 or G)

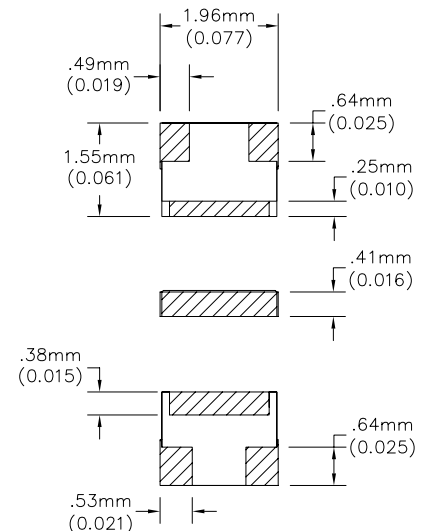
### MTVA Planar Series



### MTVA Single Wrap Series



### MTVA Triple Wrap Series

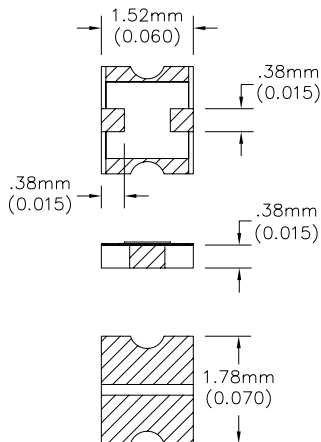




# WTVA (20.0 GHz)

Wide Band Thermopad®

## WTVA Double Wrap Wire Bond Series

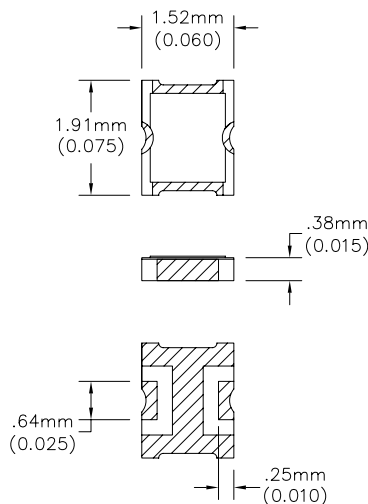


The WTVA is EMC's wide band temperature variable attenuator. This product provides a good linear shift from DC to 20 GHz and from -55°C to +125°C. EMC Technology's Thermopads® are microwave absorptive attenuators which provide power dissipation that varies with temperature. They are used to correct gain variations in amplifiers and other active components which tend to have gain anomalies over temperature. The WB2 style uses thick film gold wire bondable terminals. The SMTF style is a RoHS compliant surface mount configuration. The WTVA is the preferred version of EMC's Thermopad for use in satellite communications, broadband EW applications, and for high frequency and broadband amplifiers.

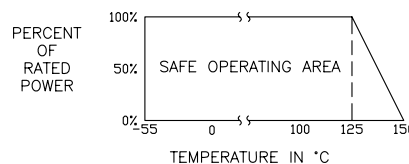
## Specifications

Size	1.52mm x 1.78mm [0.060in x 0.070in]
Impedance	50 Ohms
Frequency Range	DC to 20 GHz
TCA Tolerance	±0.001 dB/dB/°C
VSWR (Typical)	1.25:1 Max DC-10 GHZ @ 25°C 1.45:1 Max 10-20 GHZ @ 25°C
Power Rating	200 Milliwatts
Operating Temperature	-55°C to 150°C
Substrate	Alumina
Resistive Material	Thick Film
Terminal Material	Thick Film, Wire Bondable or Lead Free Finish

## WTVA Surface Mount Series



## Power Rating and Derating



## Part Numbering Code

<b>W T V A</b>	<b>0 3</b>	<b>0 0</b>	<b>N</b>	<b>0 5</b>	<b>S M T</b>	<b>F</b>
SERIES WTVA	NOMINAL ATTENUATION 02 = 2 dB through 06 = 6 dB	EMC CODE	TCA SLOPE N = Negative P = Positive	TCA (dB/dB/°C) 03 = .003 through 07 = .007	MOUNTING STYLE SMT = Surface Mount WB2 = Wire Bondable Gold	ENVIRONMENTAL COMPLIANCE (blank) = Sn60Pb40 S = Pretinning F = RoHS

# KTVA (36.0 GHz)

## K-Band Thermopad®

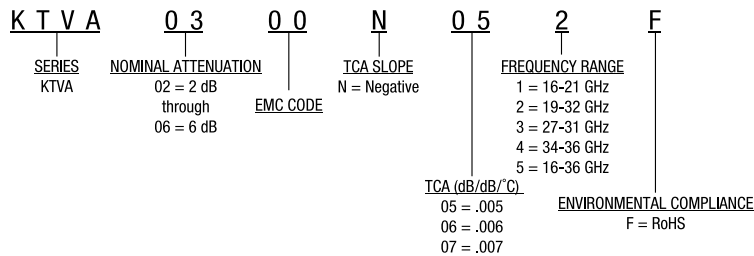


EMC Technology's KTVA high frequency Thermopads® are ideal for millimeter-wave amplifiers. KTVA is capable of handling 100 milliwatts input power and available in wire bondable and surface mount packages. Standard narrowband versions cover specific segments in K and Ka bands. An optimized broadband version operating from 16 to 36 GHz is also available. KTVA design also offers custom frequency band responses for narrow band applications with improved VSWR performance and attenuation accuracy. This product is space qualified and has flight history for those requiring pre-qualified heritage.

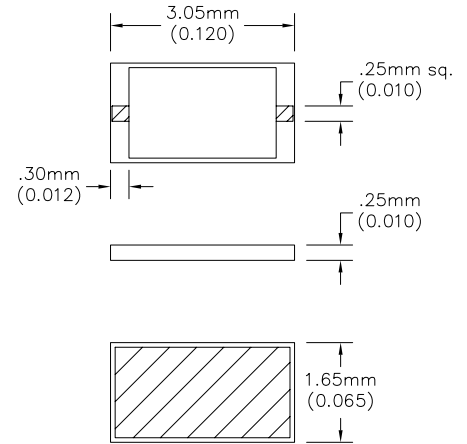
### Specifications

Size	3.05mm x 1.65mm [0.120in x 0.065in]
Impedance	50 Ohms
Frequency Range	16 to 36 GHz
TCA Tolerance	±0.001 dB/dB/°C
VSWR (Typical)	1.35 Typical
Power Rating	100 Milliwatts
Operating Temperature	-55°C to 150°C
Substrate	Alumina
Resistive Material	Thick Film
Terminal Material	Thick Film, Bondable Gold or Lead Free Finish

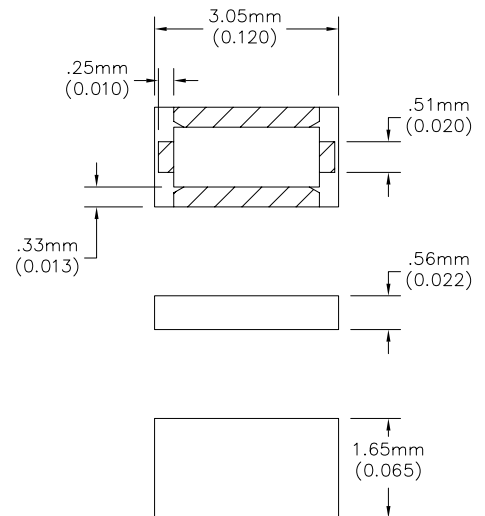
### Part Numbering Code - Wire Bond Series



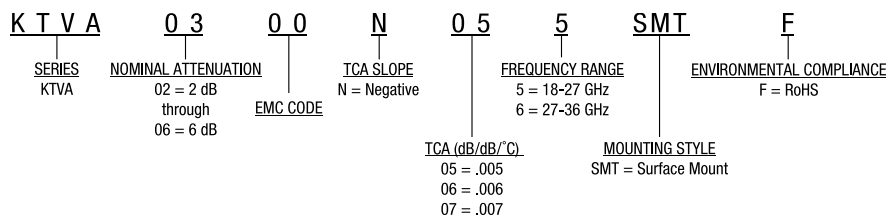
### KTVA Wire Bond Series



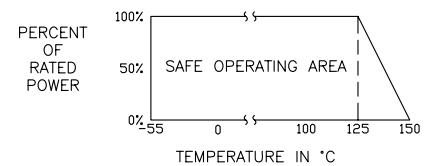
### KTVA Surface Mount Series



### Part Numbering Code - Surface Mount Series



### Power Rating and Derating



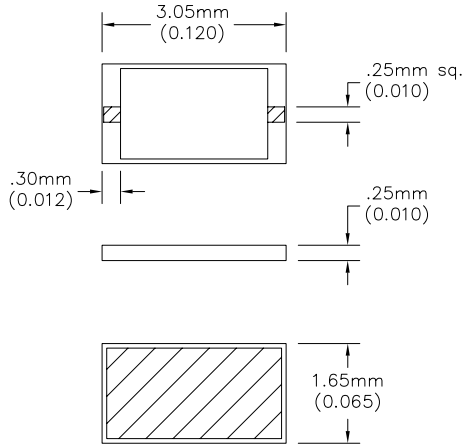




# QTV A (50.0 GHz)

Q-Band Thermopad®

## QTV A Wire Bond Series

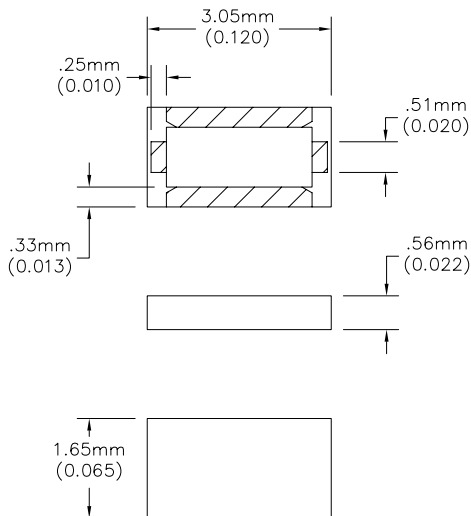


EMC Technology's QTV A high frequency Thermopads® are ideal for millimeter wave amplifiers. QTV A is capable of handling 200 milliwatts input power and available in wire bondable and surface mount packages. The devices feature optimized broadband response from 36 to 50 GHz. QTV A design also offers custom frequency band responses for narrow band applications with improved VSWR performance and attenuation accuracy.

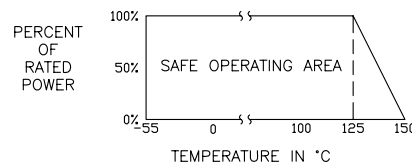
## Specifications

Size	3.05mm x 1.65mm [0.120in x 0.065in]
Impedance	50 Ohms
Frequency Range	36 to 50 GHz
TCA Tolerance	±0.001 dB/dB/°C
VSWR (Typical)	1.35 Typical
Power Rating	200 Milliwatts
Operating Temperature	-55°C to 150°C
Substrate	Alumina
Resistive Material	Thick Film
Terminal Material	Thick Film, Bondable Gold or Lead Free Finish

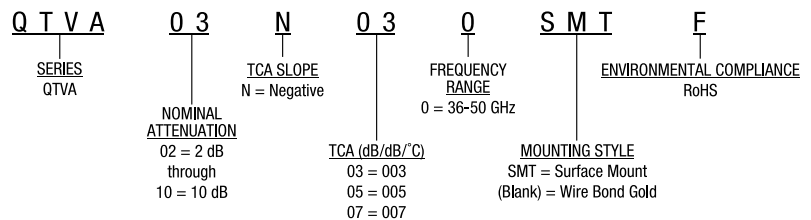
## QTV A Surface Mount Series



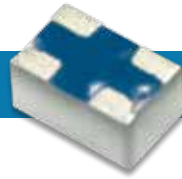
## Power Rating and Derating



## Part Numbering Code



# AN Series (6.0 GHz)



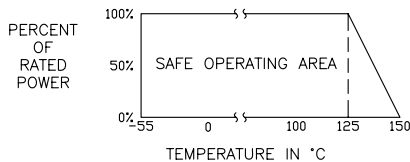
AN11, AN7, AN5 Thermopad®

The AN11, 7 and 5 series of temperature variable attenuators offers a cost effective passive temperature compensation solution for the commercial wireless industry. The series operates DC to 6 GHz. These products are sold on 1000 piece reels for high volume applications. Plating options include RoHS compliant lead free silver over nickel plating, 60/40 low temperature solder plating or 60/40 solder fused finish for easy reflow processing. This product is packaged in 1000 piece reels for high volume applications.

## Specifications

Size	AN11 1.14mm x 0.64mm [0.045in x 0.025in]
	AN7 2.03mm x 1.27mm [0.080in x 0.050in]
	AN5 1.91mm x 1.52mm [0.075in x 0.060in]
Impedance	50 Ohms
Frequency Range	DC to 6 GHz
TCA Tolerance	±0.001 dB/dB/°C
VSWR (Typical)	1.30 @ 1 GHz
Power Rating	AN5 200 Milliwatts AN7 AN11 100 Milliwatts
Operating Temperature	-55°C to 150°C
Substrate	Alumina
Resistive Material	Thick Film
Terminal Material	Thick Film, Nickel Barrier with Solder Plate or Lead Free Finish.

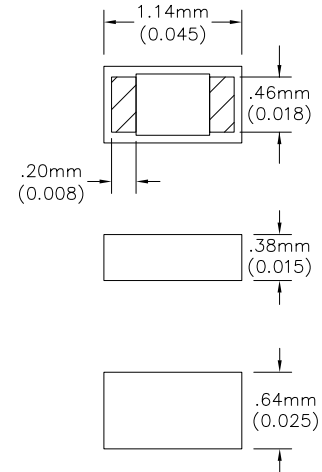
## Power Rating and Derating



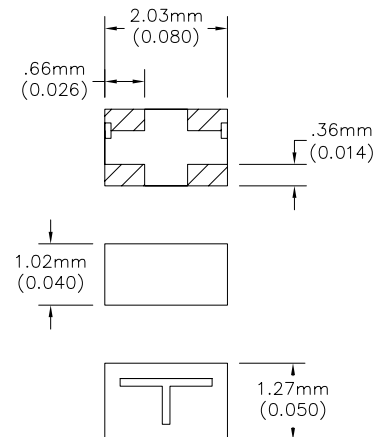
## Part Numbering Code

<b>A N 5</b>	-	<b>X</b>	<b>N</b>	<b>X</b>	<b>F</b>
<u>SERIES</u>		<u>NOMINAL ATTENUATION</u>		<u>TCA (dB/dB/°C)</u>	<u>ENVIRONMENTAL COMPLIANCE</u>
AN5		AN5 - 1 to 10 dB		3 = .003	(blank) = Sn60Pb40
AN7		AN7 - 1 to 7 dB		4 = .004	F = RoHS
AN11		AN11 - 1 to 2 dB		5 = .005	
				6 = .006	
				7 = .007	
				9 = .009	
			<u>TCA SLOPE</u>		
			N = Negative		

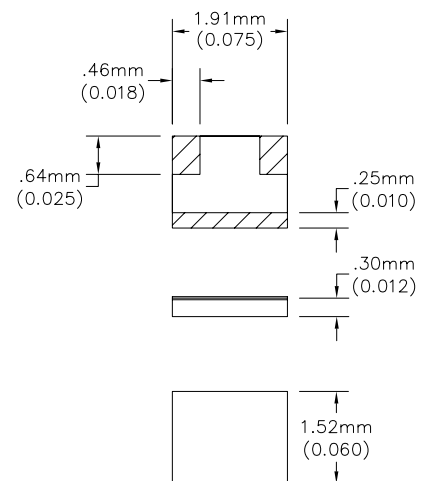
### AN11 Planar Series

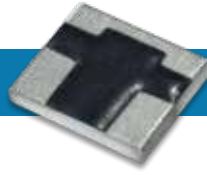


### AN7 Planar Series



### AN5 Planar Series

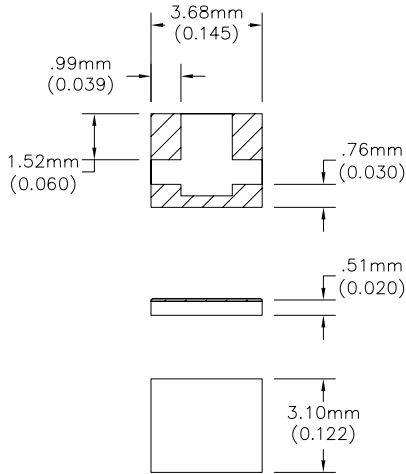




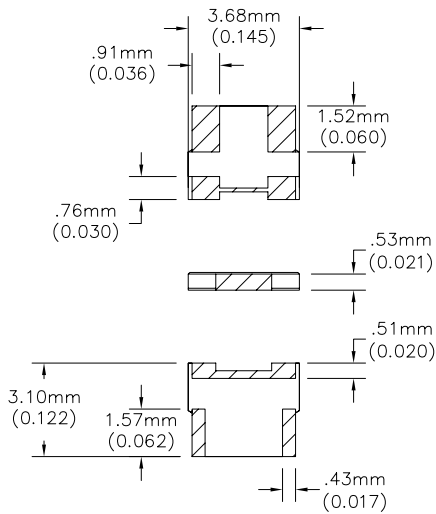
# AN Series (4.0 GHz)

AN3 Thermopad®

## AN3 Planar Series



## AN3 Triple Wrap Series

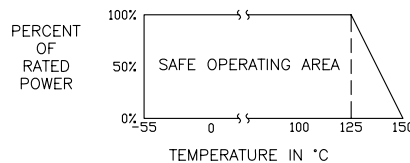


The AN3 series of temperature variable attenuators offers a cost effective passive temperature compensation solution for the commercial wireless industry. The series operates DC to 4 GHz. And is available with 2 metallization styles, planar and triple wrap. Plating options include RoHS compliant lead free silver over nickel plating, 60/40 low temperature solder finish or 60/40 solder fused finish for easy reflow processing. This product is packaged in 1000 piece reels for high volume applications.

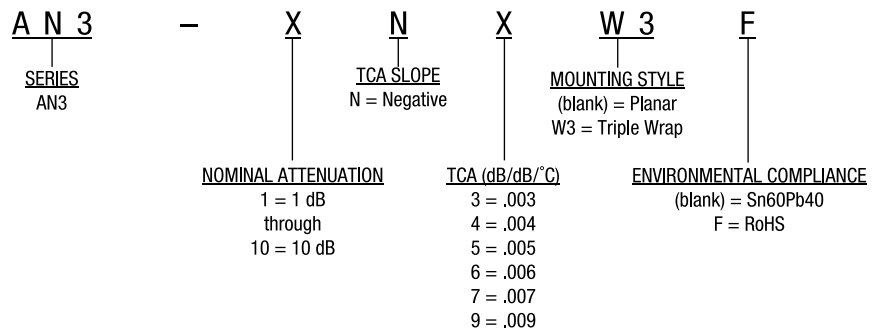
## Specifications

Size	3.10mm x 3.68mm [0.122in x 0.145in]
Impedance	50 Ohms
Frequency Range	DC to 4 GHz
TCA Tolerance	±0.001 dB/dB/°C
VSWR (Typical)	1.30 @ 1 GHz
Power Rating	2 Watts
Operating Temperature	-55°C to 150°C
Substrate	Alumina
Resistive Material	Thick Film
Terminal Material	Thick Film, Nickel Barrier with Solder Plate or Lead Free Finish.

## Power Rating and Derating



## Part Numbering Code



# CTVA

## Broadband and Cable Thermopad®

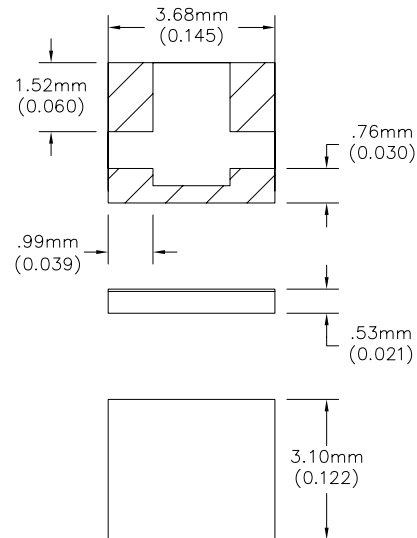


CTVA Thermopad® is a 75 ohm version of the standard temperature variable attenuator. It can be used in 75 ohm applications where variable dissipated power is required over temperature. This product is available with planar and triple wrap metallization styles. Available plating options include RoHS compliant silver over nickel finish, 60/40 low-temperature solder plating, and 60/40 solder fused finish.

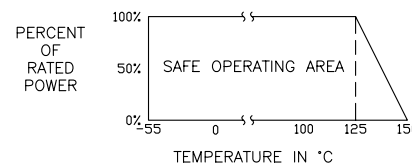
### Specifications

Size	3.10 mm x 3.68 mm [0.122 in x 0.145 in]
Impedance	75 Ohms
Frequency Range	DC to 4 GHz
TCA Tolerance	±0.001 dB/dB/°C
VSWR (Typical)	1.25 @ 1 GHz
Power Rating	2.0 Watts
Operating Temperature	-55°C to 150°C
Substrate	Alumina
Resistive Material	Thick Film
Terminal Material	Thick Film, Nickel Barrier with Solder Plate or Lead Free Finish.

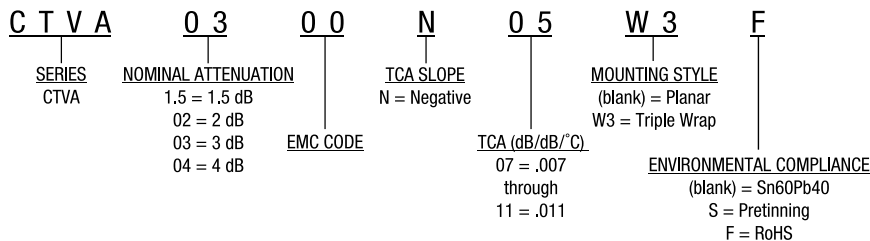
### CTVA Planar Series

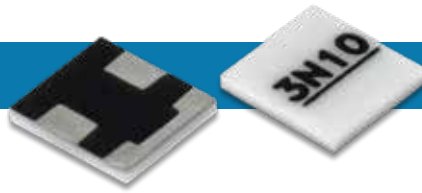


### Power Rating and Derating



### Part Numbering Code

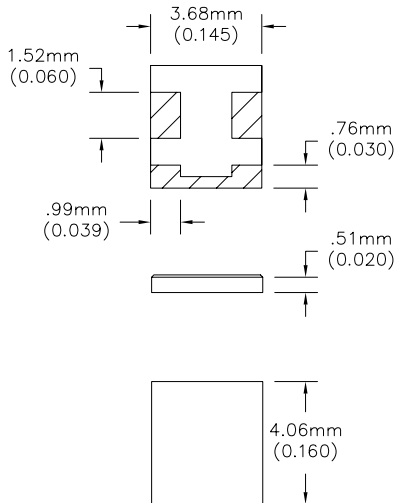




## ETVA (3.0 GHz)

Extended Shift Thermopad®

### ETVA Planar Series

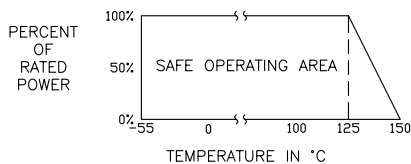


ETVA Thermopads® are microwave absorptive attenuators which provide power dissipation that varies with temperature and operate in frequency ranges from DC to 3 GHz. The ETVA features higher temperature coefficient of attenuation, therefore allowing for greater gain variation compensation. This surface mount, temperature variable attenuator requires no bias or control voltages and generates zero distortion. This product is available with various metallization styles and plating options including RoHS compliant lead free silver over nickel plating, 60/40 low temperature solder plating or 60/40 solder fused finish for easy reflow processing.

### Specifications

Size	4.06 mm x 3.68 mm [0.160 in x 0.145 in]
Impedance	50 Ohms
Frequency Range	DC to 3 GHz
TCA Tolerance	±0.001 dB/dB/°C
VSWR (Typical)	1.30 @ 1 GHz
Power Rating	2.0 Watts
Operating Temperature	-55°C to 150°C
Substrate	Alumina
Resistive Material	Thick Film
Terminal Material	Thick Film, Nickel Barrier with Solder Plate or Lead Free Finish.

### Power Rating and Derating



### Part Numbering Code

<b>E T V A</b>	<b>0 3</b>	<b>0 0</b>	<b>N</b>	<b>0 5</b>	<b>S</b>
<u>SERIES</u> ETVA	<u>NOMINAL ATTENUATION</u> 03 = 3 dB through 06 = 6 dB	<u>EMC CODE</u>	<u>TCA SLOPE</u> N = Negative	<u>TCA (dB/dB/°C)</u> 10 = .010 through 16 = .016	<u>ENVIRONMENTAL COMPLIANCE</u> (blank) = Sn60Pb40 S = Pretinning F = RoHS

# Specialty Thermopads

Coaxial Thermopad®



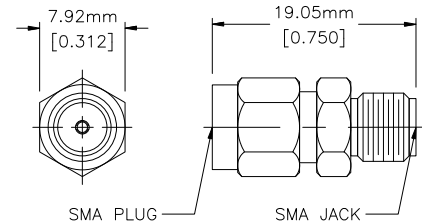
Combining EMC Technology components with Florida RF Labs connector expertise to offer the popular temperature variable attenuator in a coaxial package. The coaxial Thermopad® offers the same benefits as the standard temperature variable attenuator with the added benefit of an SMA plug to SMA jack interface.

## Specifications

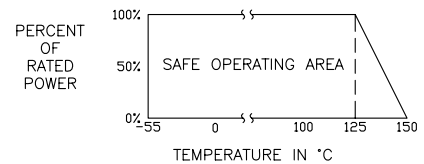
42TVA

Size	19.05 mm x 7.92 mm [0.750 in x 0.312 in]
Impedance	50 Ohms
Frequency Range	DC to 6 GHz
TCA Tolerance	±0.001 dB/dB/°C
VSWR (Typical)	1.35 @ 1 GHz
Power Rating	2.0 Watts
Operating Temperature	-55°C to 150°C
Substrate	Alumina
Resistive Material	Thick Film
Terminal Material	Plated Thick Film
Body and Nut	Stainless Steel
Contact	Beryllium Copper
Dielectric	Tetrafluoroethylene
Interface	SMA Male/ SMA Female
Body	Passivated

## 42TVA Series



## Power Rating and Derating



## Part Numbering Code

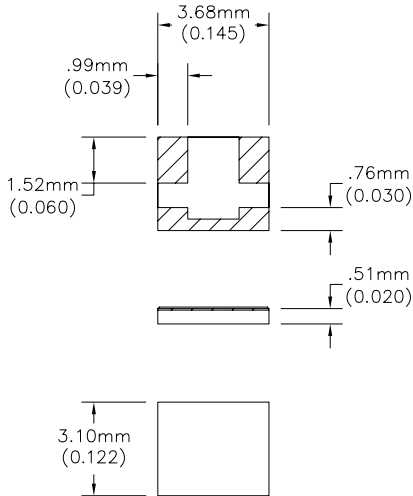
**4 2 T V A**      **0 3**      **0 0**      **N**      **0 5**      **F**  
SERIES      NOMINAL ATTENUATION      EMC CODE      TCA SLOPE      TCA (dB/dB/°C)      ENVIRONMENTAL COMPLIANCE  
 42TVA      01 = 1 dB through 10 = 10 dB      N = Negative P = Positive      03 = .003 through 09 = .009      (blank) = Standard F = RoHS



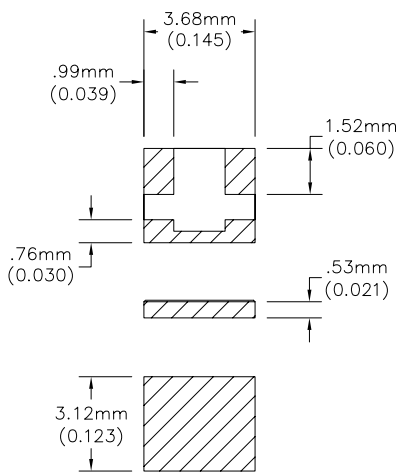
# HRT (6.0 GHz)

High Reliability Thermopad®

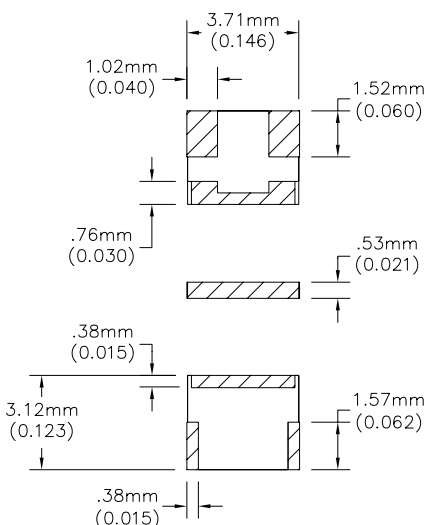
## HRT Planar Series



## HRT Single Wrap Series



## HRT Triple Wrap Series

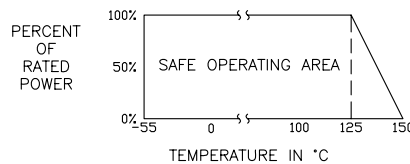


EMC's Thermopad®, temperature variable attenuator, is S-Level qualified for high reliability applications. As a completely passive temperature compensation solution, Thermopad offers the benefits of reduced system complexity and improved overall reliability, which are critical for space and military applications. The HR series of the TVA is optimized for DC to 6 GHz operation and may be ordered with group A, B, or C testing based on Mil-PRF-55342.

## Specifications

Size	3.10mm x 3.68mm [0.122 in x 0.145 in]
Impedance	50 Ohms
Frequency Range	DC to 6 GHz
TCA Tolerance	±0.001 dB/dB/°C
VSWR (Typical)	1.30 @ 1 GHz
Power Rating	2.0 Watts
Operating Temperature	-55 °C to 150 °C
Substrate	Alumina
Resistive Material	Thick film
Terminal Material	Thick film, Nickel Barrier with Solder Plated Finish

## Power Rating and Derating



## Part Numbering Code

<b>HRT</b>	<b>03</b>	<b>0A</b>	<b>N</b>	<b>05</b>	<b>W3</b>	<b>S</b>
<b>SERIES</b> HRT	<b>NOMINAL ATTENUATION</b> 01 = 1 dB through 10 = 10 dB	<b>TESTING</b> 0A = Group A 0B = Group B 0C = Group C	<b>TCA SLOPE</b> N = Negative P = Positive	<b>TCA (dB/dB/°C)</b> 03 = .003 through 09 = .009	<b>MOUNTING STYLE</b> (blank) = Planar W3 = Triple Wrap W1 = Single Wrap WB1 = Wire Bondable Gold	<b>ENVIRONMENTAL COMPLIANCE</b> (blank) = Sn60Pb40 S = Pretinning G = Gold F = RoHS (not available on WB1 or G)

See page 105 for test plan.

# HRM (18.0 GHz)

High Reliability Mini Thermopad®

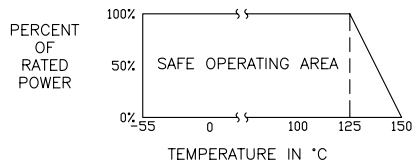


EMC's miniature size Thermopad®, temperature variable attenuator, is S-Level qualified for high reliability applications. As a completely passive temperature compensation solution, Thermopad offers the benefits of reduced system complexity and improved overall reliability, which are critical for space and military applications. The HR series of the MTVA is optimized for DC to 18 GHz operation and may be ordered with group A, B, or C testing based on Mil-PRF-55342.

## Specifications

Size	1.52 mm x 1.91 mm [0.060 in x 0.075 in]
Impedance	50 Ohms
Frequency Range	DC to 18 GHz
TCA Tolerance	±0.001 dB/dB/°C
VSWR (Typical)	1.30 @ 1 GHz
Power Rating	200 Milliwatts
Operating Temperature	-55°C to 150°C
Substrate	Alumina
Resistive Material	Thick Film
Terminal Material	Thick Film, Nickel Barrier with Solder Plated Finish

## Power Rating and Derating

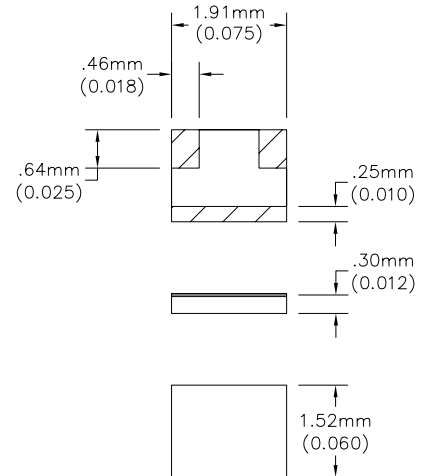


## Part Numbering Code

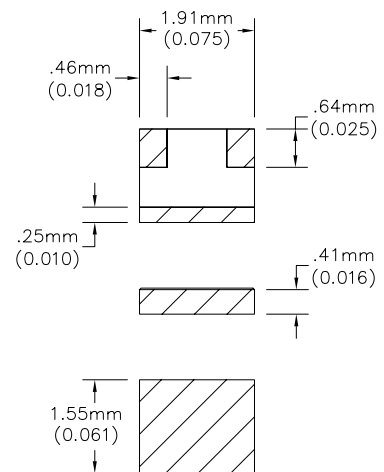
<b>H R M</b>	<b>0 3</b>	<b>0 A</b>	<b>N</b>	<b>0 5</b>	<b>W 3</b>	<b>S</b>
SERIES HRM	NOMINAL ATTENUATION 01 = 1 dB through 09 = 9 dB	TESTING 0A = Group A 0B = Group B 0C = Group C	TCA SLOPE N = Negative	TCA (dB/dB/°C) 03 = .003 through 09 = .009	MOUNTING STYLE (blank) = Planar W3 = Triple Wrap W1 = Single Wrap WB1 = Wire Bondable Gold	ENVIRONMENTAL COMPLIANCE (blank) = Sn60Pb40 S = Pretinning G = Gold F = RoHS (Not available on WB1)

See page 105 for test plan.

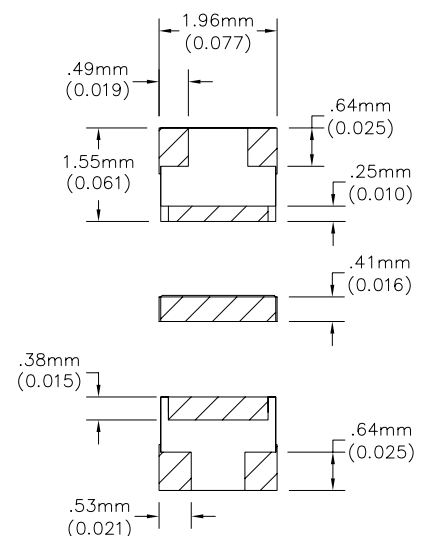
## HRM Planar Series



## HRM Single Wrap Series



## HRM Triple Wrap Series





### Features

- Substrates - BeO, AlN, Alumina and CVD Diamond
- Commercial and High Reliability Product Lines
- Frequency Range from DC to 50 GHz
- Attenuation Values from 0 to 30 dB
- Space and Military Qualified
- Surface Mount, Wire-Bondable and Coaxial Configurations

### Benefits

- Small Footprint
- Totally Passive
- Power Handling up to 400 Watts
- Several Metallization Options Available, Including a RoHS Compliant Version

### Applications

- Circulators
- High Power Amplifiers
- Receivers
- Filters
- Isolators
- Signal Sampling
- Interstage Isolation
- Impedance Matching

**For our CVD Diamond Attenuators see Diamond Rf Resistives® on pages 65 to 74**



We are the world leader in fixed attenuators from DC through Q band. Fixed attenuators are available in 0.1 to 400 watt versions, covering DC to 50 GHz applications and offered in 0 to 30 dB values. Our attenuators are available in many package styles including chip, tab & cover, flange and coaxial models for use in both low and high power applications. These products are available in standard commercial product as well as high reliability versions.

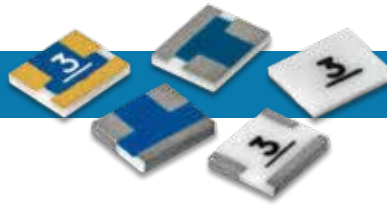
### Quick Selector Chart

Series	Frequency (GHz)	Power (Watts)	Footprint mm [inches]		Page
TS03	DC - 12.4	2	3.10 x 3.68	[0.122 x 0.145]	18
TS04	DC - 6.0	1	3.18 x 2.54	[0.125 x 0.100]	23
TS05	DC - 18.0	0.1	1.52 x 1.91	[0.060 x 0.075]	19
TS06	DC - 20.0	0.2	0.89 x 1.65	[0.035 x 0.065]	24
TS07	DC - 6.0	0.1	2.03 x 1.27	[0.080 x 0.050]	23
TS09	DC - 20.0	0.2	1.78 x 1.52	[0.070 x 0.060]	22
KFA	16.0 - 36.0	0.2	3.05 x 1.65	[0.120 x 0.065]	20
QFA	36.0 - 50.0	0.2	3.05 x 1.65	[0.120 x 0.065]	21
HPCA	DC - 2.5	20	6.22 x 6.22	[0.245 x 0.245]	25
83 Chip	DC - 18.0	120*	Various	Various	26-27
Tab & Cover	DC - 4.0	250*	Various	Various	28-30
Flange	DC - 4.0	400*	Various	Various	31-33
42 Coaxial	DC - 18.0	2	Various	Various	36
HR03	DC - 12.4	2	3.10 x 3.68	[0.122 x 0.145]	35
HR05	DC - 18.0	0.1	1.52 x 1.91	[0.060 x 0.075]	34

\* Maximum Power

# TS03 (12.4 GHz)

## Chip Attenuator

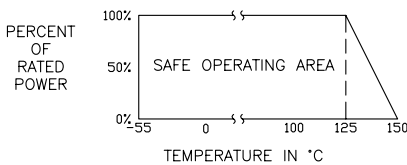


EMC Technology's TS03 chip attenuators have a rated input power of 2 watts with attenuation values from 0 dB to 20 dB and work from DC to 12.4 GHz. These chip devices are available with several metallization styles and plating options including RoHS compliant lead free silver over nickel finish, solder plate, or fused solder finish for easy reflow processing.

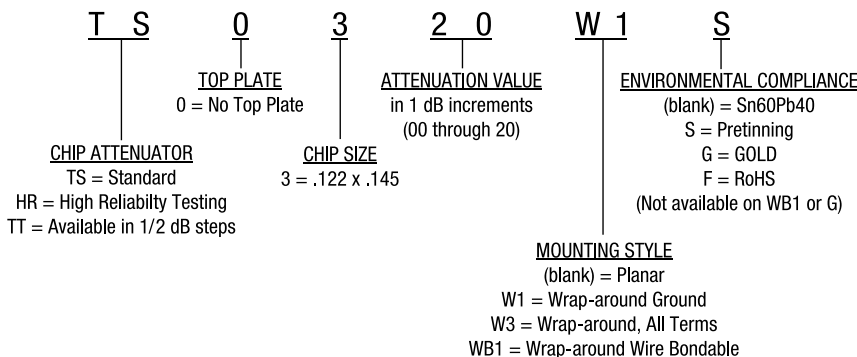
### Specifications

Size	3.10mm x 3.68mm [0.122in x 0.145in]
Impedance	50 Ohms
Frequency Range	Planar Series DC to 12.4 GHz W Series DC to 8 GHz
VSWR (Typical)	1.30
Power Rating	2.0 Watts
Operating Temperature	-55°C to 150°C
Substrate	Alumina
Resistive Material	Thick Film
Terminal Material	Thick Film, Nickel Barrier with Solder Plated or RoHS, Gold and Wire Bondable Options Available

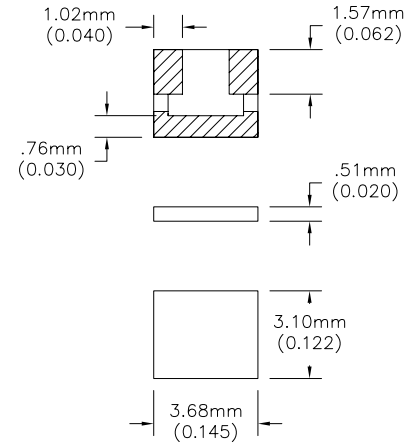
### Power Rating and Derating



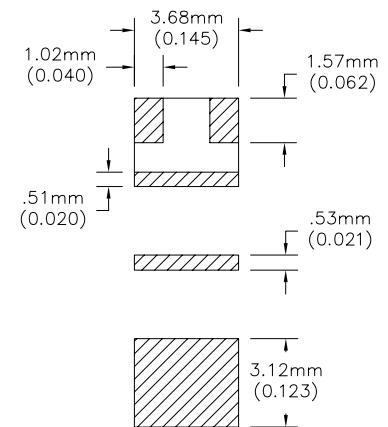
### Part Numbering Code



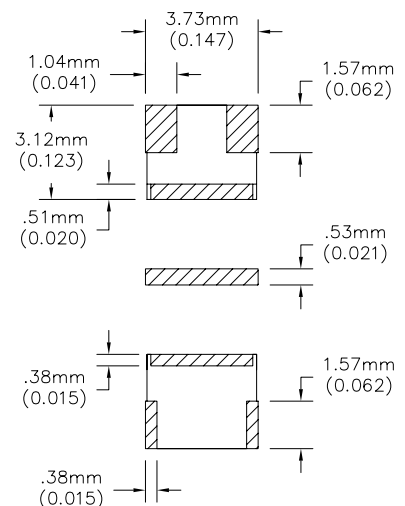
### TS03 Planar Series

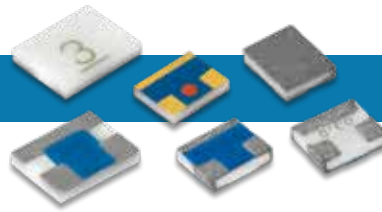


### TS03 Single Wrap Series



### TS03 Triple Wrap Series

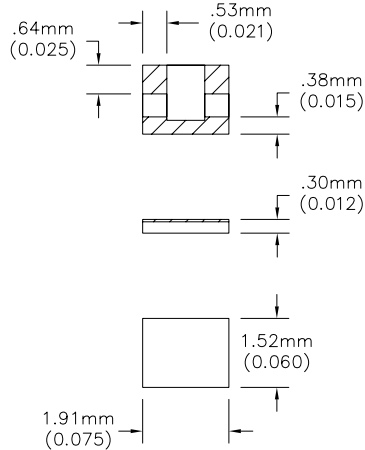




# TS05 (18.0 GHz)

## Chip Attenuator

### TS05 Planar Series

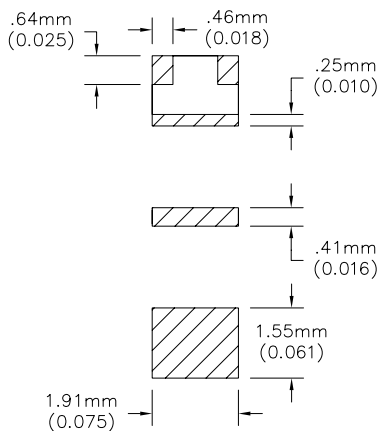


EMC Technology's TS05 series chip attenuators feature DC - 18 GHz operating frequency range with power handling capability of 100 milliwatts. Standard attenuation values range from 0 to 20 dB. These chip devices are available with several metallization styles and plating options including RoHS compliant lead free silver over nickel finish, solder plate, or fused solder finish for easy reflow processing.

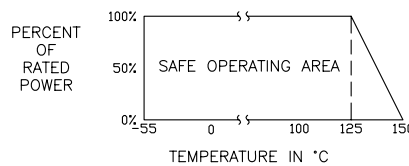
### Specifications

Size	1.52mm x 1.91mm [0.060in x 0.075in]
Impedance	50 Ohms
Frequency Range	Planar Series DC to 18 GHz W Series DC to 12.4 GHz
VSWR (Typical)	1.30
Power Rating	100 Milliwatts
Operating Temperature	-55°C to 150°C
Substrate	Alumina
Resistive Material	Thin Film
Terminal Material	Thick Film, Nickel Barrier with Solder Plated or RoHS, Gold and Wire Bondable options available

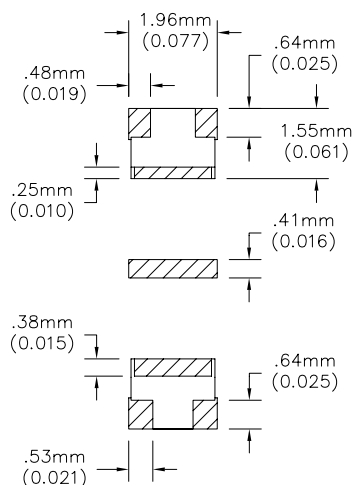
### TS05 Single Wrap Series



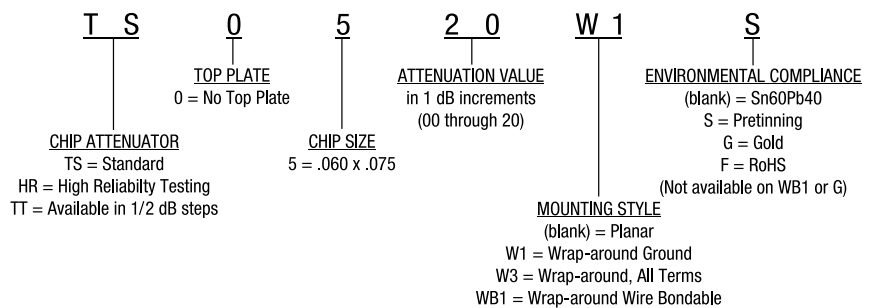
### Power Rating and Derating



### TS05 Triple Wrap Series



### Part Numbering Code



# KFA (36.0 GHz)

## K-Band Attenuator

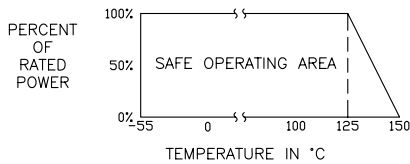


EMC Technology's KFA series fixed attenuators are footprint-compatible with KTVA and operate from 16 to 36 GHz. Standard attenuation values from 1 to 10 dB are available. The KFA is also available for high-reliability applications under the HRKFA part number with Group A, B and C testing according to Mil-PRF-55342. This attenuator is available with wire-bondable gold terminals and a platinum silver, solder attachable ground plane.

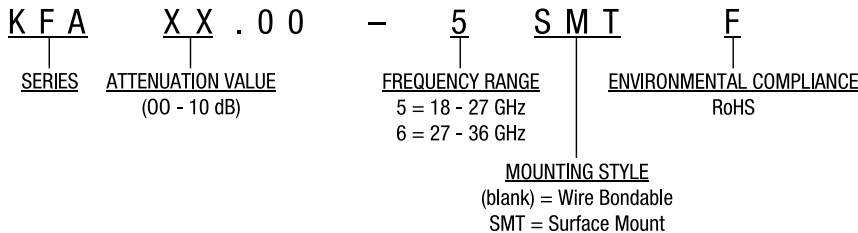
### Specifications

Size	3.05mm x 1.65mm [0.120in x 0.065]
Impedance	50 Ohms
Frequency Range	16 to 36 GHz
VSWR (Typical)	1.35
Power Rating	200 Milliwatts
Operating Temperature	-55°C to 150°C
Substrate	Alumina
Resistive Material	Thin Film
Terminal Material	Thick Film, Bondable Gold or Lead Free Finish

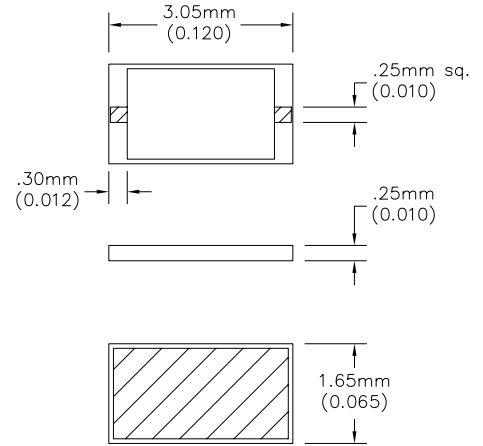
### Power Rating and Derating



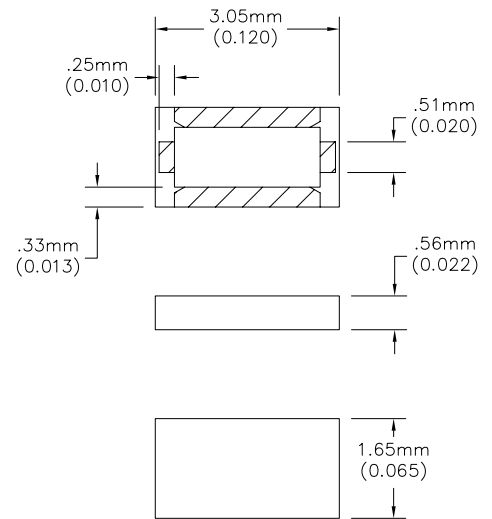
### Part Numbering Code

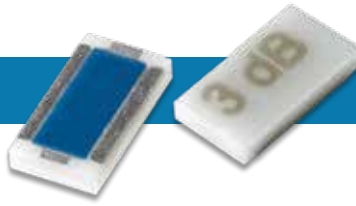


### KFA Wire Bond Series

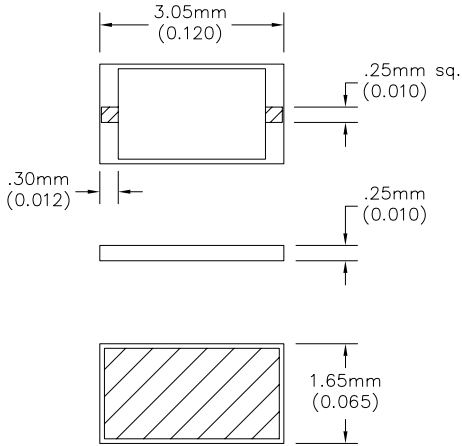


### KFA Surface Mount Series





### QFA Wire Bond Series

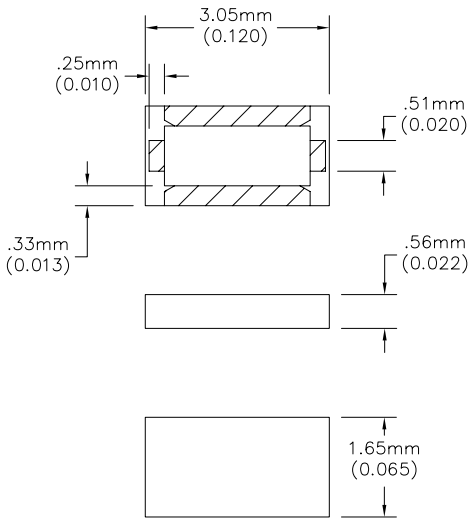


The QFA series offers passive fixed attenuation from 36 to 50 GHz. Being passive in nature, there is no signal distortion, phase shift or time delay. The attenuator structure is internally tuned for optimum performance beyond Ka band, with the added benefit of being a truly symmetrical, bidirectional attenuator. The QFA is available in surface mount packaging. The QFA was developed to address commercialization of point-to-point radio, high frequency transceivers, and phased array radar. The device comes in two styles, microstrip and coplanar, with excellent frequency response from 36 through 50 GHz and is available in designs of 0 to 10dB. The QFA handles 200 milliwatts of input power and has a small 1206 footprint. All values are available in RoHS versions and all can be supplied on tape and reel for high volume pick and place applications.

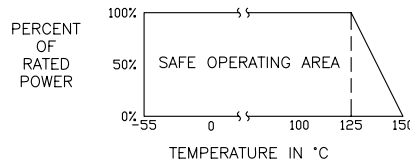
### Specifications

Size	3.05mm x 1.65mm [0.120in x 0.065in]
Impedance	50 Ohms
Frequency Range	36 to 50 GHz
VSWR (Typical)	1.35
Power Rating	200 Milliwatts
Operating Temperature	-55°C to 150°C
Substrate	Alumina
Resistive Material	Thin Film
Terminal Material	Thick Film, Bondable Gold or Lead Free

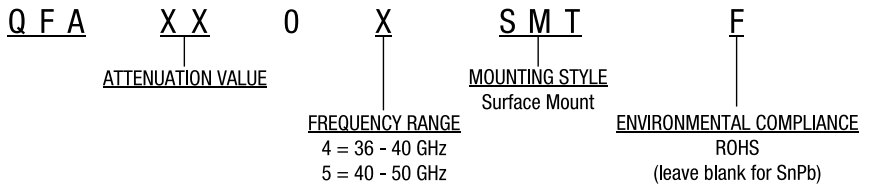
### QFA Surface Mount Series



### Power Rating and Derating

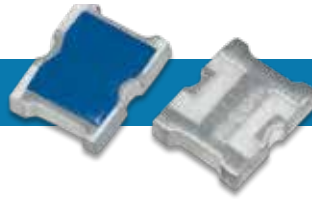


### Part Numbering Code



# TS09 (20.0 GHz)

## Chip Attenuator

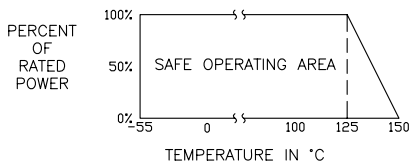


EMC Technology's TS09 chip attenuators offer rated input power of 200 milliwatts with attenuation values from 0 dB to 10 dB at DC - 20 GHz. This product is available with various metallization styles and plating options including RoHS compliant silver over nickel, solder plated tin/lead, solder fused for easy reflow processing. The WB2 style uses thick film wire-bondable gold terminals.

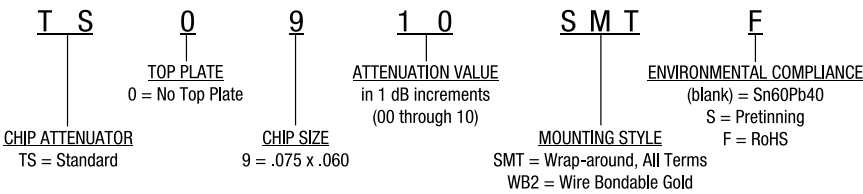
### Specifications

Size	1.52mm x 1.78mm [0.060in x 0.070in]
Impedance	50 Ohms
Frequency Range	DC to 20 GHz
VSWR (Typical)	1.40
Power Rating	200 Milliwatts
Operating Temperature	-55°C to 150°C
Substrate	Alumina
Resistive Material	Thick Film
Terminal Material	Thick Film, Bondable Gold or Lead Free

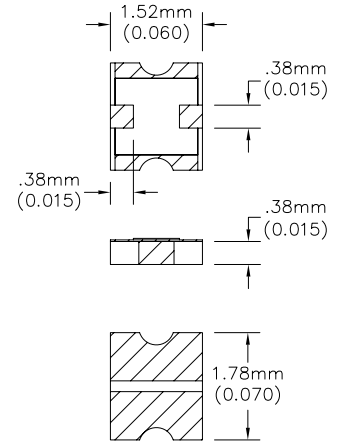
### Power Rating and Derating



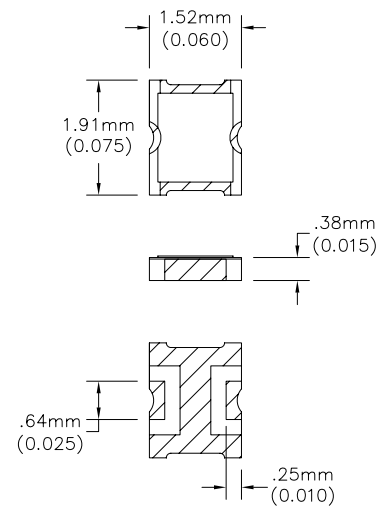
### Part Numbering Code

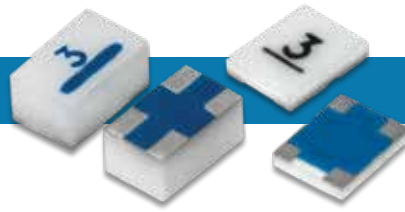


### TS09 Double Wrap Wire Bond Series

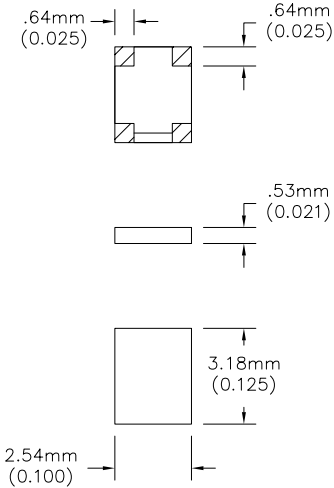


### TS09 Surface Mount Series





### TS04 Planar Series

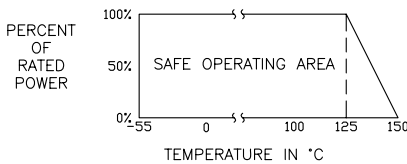


The TS04 series chip attenuators are designed for operation in commercial wireless spectrum and perform optimally in narrow band applications with low input power requirements up to 1 watt. Plating options include RoHS compliant lead free silver over nickel finish, SN62 solder plating or fused solder finish for easy reflow processing.

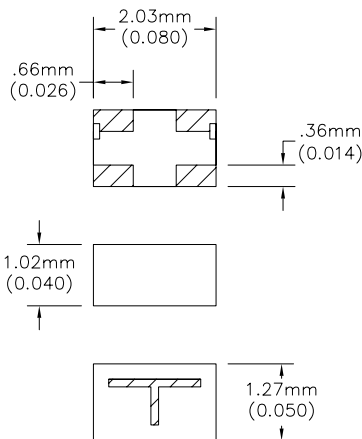
### Specifications

	TS04	TS07
Size	3.18mm x 2.54mm [0.125in x 0.100in]	2.03mm x 1.27mm [0.080in x 0.050in]
Impedance	50 Ohms	50 Ohms
Frequency Range	DC to 6 GHz	DC to 6 GHz
VSWR (Typical)	1.35	1.5
Power Rating	1.0 Watts	100 Milliwatts
Operating Temperature	-55°C to 150°C	-55°C to 150°C
Substrate	Alumina	Alumina
Resistive Material	Thick Film	Thick Film
Terminal Material	Thick Film, Nickel Barrier, Solder Plated or RoHS,	Thick Film, Lead Free Finish

### Power Rating and Derating

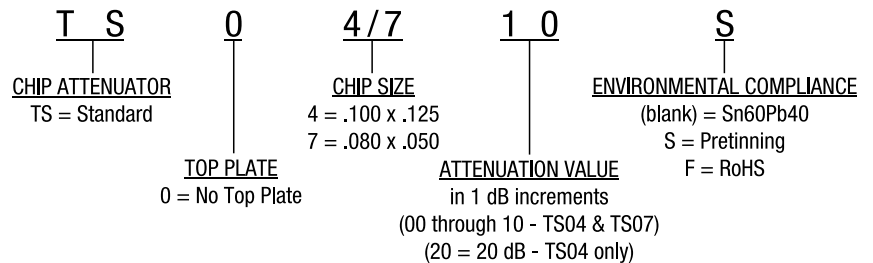


### TS07 Planar Series



The TS07XX(F) is an SMT fixed attenuator and is suitable for all Telecom and WiMax applications. This conveniently sized 0805 chip attenuator has excellent frequency response from DC to 6 GHz. The TS07 series is available in attenuation values of 0 through 10 dB in one dB increments and operates within a temperature range of -55 to +125 °C. This cost effective attenuator can handle 100 milliwatts of input power and is packaged on 1,000 piece reels for high volume, pick and place assembly. All values are RoHS compliant.

### Part Numbering Code



# TS06 (DC-20 GHz)

## Chip Attenuator

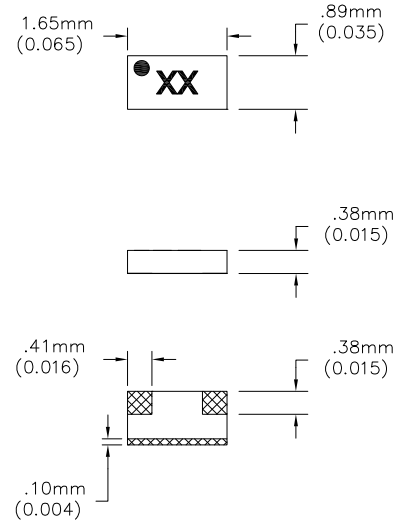


EMC Technology's trailblazing research and development in resistive technology over the last five decades have culminated in yet another advanced fixed attenuator series. Our latest TS06 series is compact in size and excellent in frequency response. Featuring a space-saving 0603 footprint without sacrificing power handling capability, the TS06 series is the best performer among our existing small-signal fixed attenuators in terms of attenuation accuracy and VSWR. TS06 series is the most ideal and balanced solution for designers needing a sub-20 GHz fixed attenuator in their space, defense, and commercial wireless applications.

### Specifications

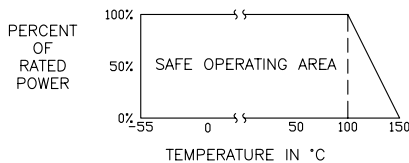
Size	0.89mm x 1.65mm [0.035in x 0.065in]
Impedance	50 Ohms
Frequency Range	DC to 20 GHz
VSWR (Typical)	1.40
Power Rating	200 Milliwatts
Operating Temperature	-55°C to 150°C
Substrate	Alumina
Resistive Material	Thin Film
Terminal Material	Thin Film

### TS06 Single Wrap Series

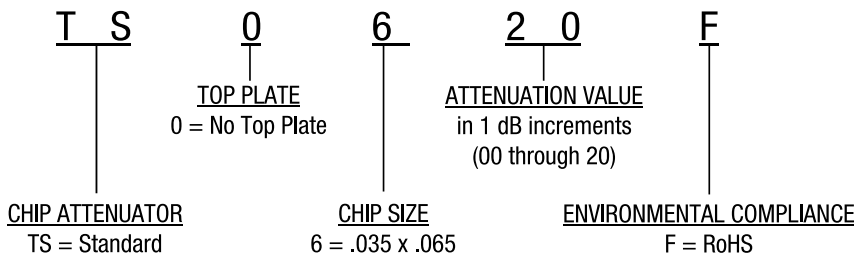


### Power Rating and Derating

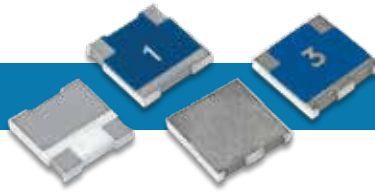
POWER RATING AND DERATING



### Part Numbering Code



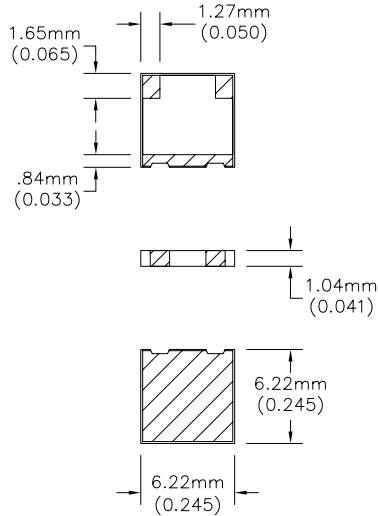




# HPCA (2.5 GHz)

High Power Chip Attenuator

## HPCA Single Wrap Series

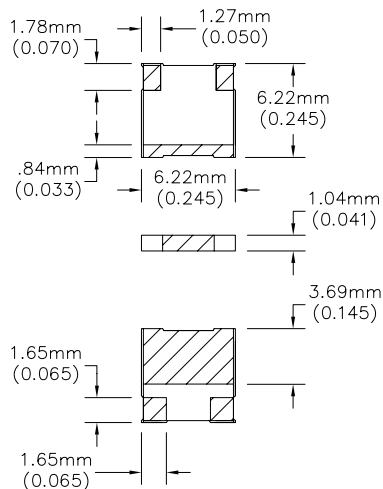


The HPCA high power chip attenuators are manufactured using thick film process and offer input power of 20 watts with attenuation values from 0 dB to 20 dB. They are designed to work from DC to 2.5 GHz. These chip devices are available with triple wrap and single wrap metallization styles and include solder finish, fused solder and RoHS compliant lead-free silver over nickel finish.

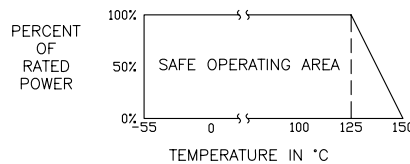
## Specifications

Size	6.22mm x 6.22mm [0.245in x 0.245in]
Impedance	50 Ohms
Frequency Range	DC to 2.5 GHz
VSWR (Typical)	1.35
Power Rating	20 Watts
Operating Temperature	-55°C to 150°C
Substrate	BeO
Resistive Material	Thick Film
Terminal Material	Thick Film, Nickel Barrier, Solder Plated or Lead Free

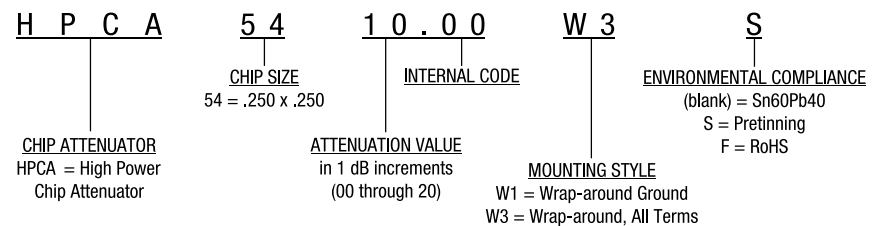
## HPCA Triple Wrap Series



## Power Rating and Derating

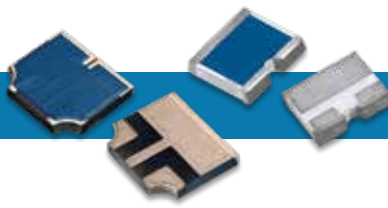


## Part Numbering Code

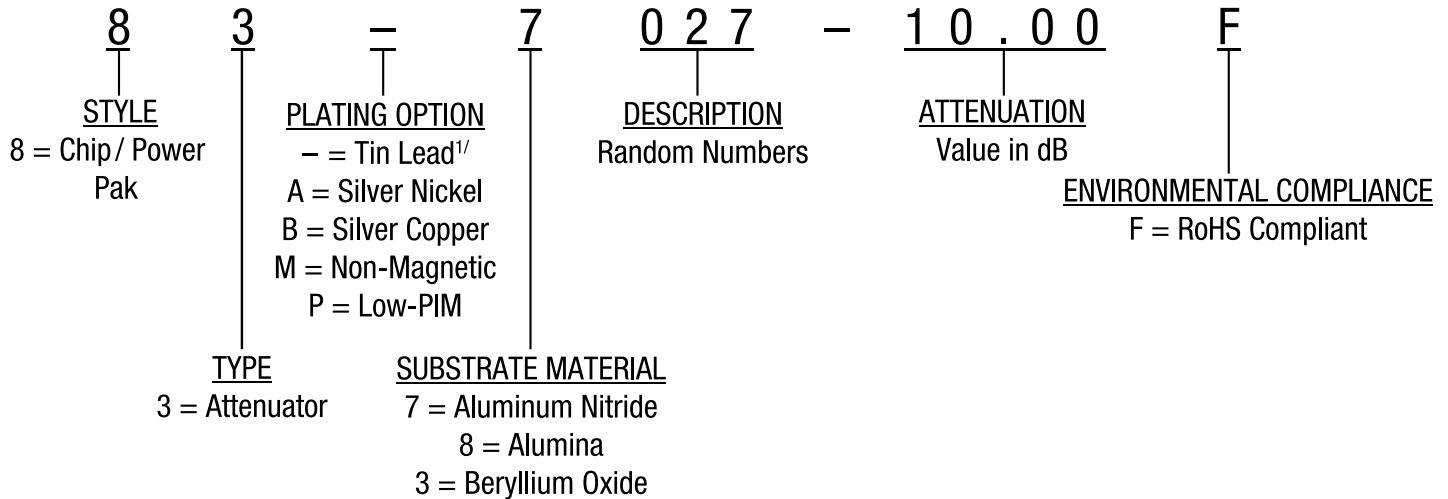


# 83 Series

## SMT Chip Attenuator



### Part Numbering Code



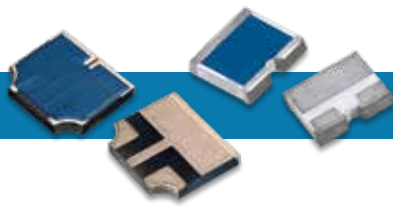
<sup>1/</sup>Not RoHS Compliant

### Product Information Table

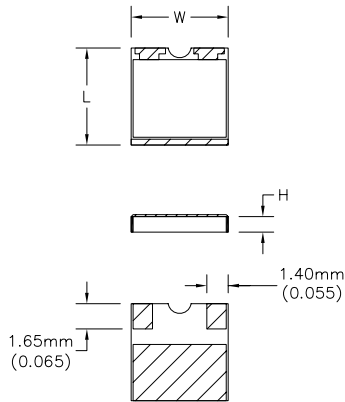
Power	Frequency	VSWR	L		W		H		Part Series #	Figure #
	GHz	Max:1	mm [inches]							
5	3.0	1.50	4.44	[0.175]	5.08	[0.200]	1.02	[0.040]	83 3995*	1
5	2.0	1.30	3.81	[0.150]	4.45	[0.175]	1.02	[0.040]	83 8999*	1
7	3.0	1.35	5.97	[0.235]	2.87	[0.113]	0.64	[0.025]	83 8054*	3
10	3.0	1.50	6.35	[0.250]	6.35	[0.250]	1.02	[0.040]	83 7999*	1
10	2.0	1.35	5.08	[0.200]	2.54	[0.100]	1.02	[0.040]	83 7014*	3
10	3.0	1.50	6.35	[0.250]	6.35	[0.250]	1.02	[0.040]	83 3999*	1
20	3.0	1.50	9.53	[0.375]	9.53	[0.375]	1.02	[0.040]	83 7027*	1
20	6.0	1.40	5.08	[0.200]	4.45	[0.175]	0.64	[0.025]	83 7044*	1
25	2.0	1.40	9.53	[0.375]	9.53	[0.375]	1.02	[0.040]	83 3998*	1
20	3.0	1.22	5.08	[0.200]	2.54	[0.100]	0.38	[0.015]	83 7046*	3
50	3.0	1.22	6.35	[0.250]	6.35	[0.250]	0.64	[0.025]	83 7047*	2
75	2.4	1.25	7.62	[0.250]	6.35	[0.250]	1.02	[0.040]	83 7012* /2	3
120	2.4	1.20	5.84	[0.230]	8.89	[0.350]	1.02	[0.040]	83 7026*	2

\* is a place holder. See part number configurations to complete the part number.

/2 only available in 30dB



**Figure 1**

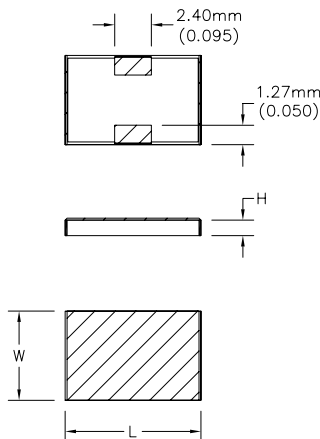


The 83 series surface mount chip attenuators are designed for direct installation on printed circuit boards and manufactured using thin film process. Edge metallization on two sides forms the solder fillets for stronger attachment, easier inspection, and increased heat removal area. The devices are available in Alumina, Aluminum Nitride (AlN) or BeO. RoHS-compliant versions are available.

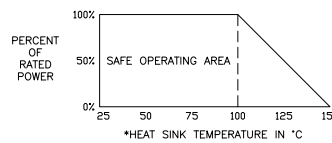
**Specifications**

Impedance	50 Ohms
Frequency Range	DC to 18 GHz
VSWR (Typical)	1.30
Power Rating	5 - 120 Watts
Operating Temperature	-55°C to 150°C
Substrate	Alumina, BeO and AlN
Resistive Material	Thin Film
Terminal Material	Thick Film, Nickel Barrier, Solder Plated or RoHS, Gold and Wire Bondable Options Available

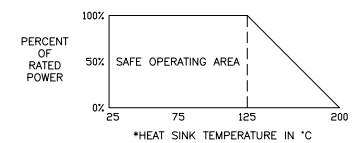
**Figure 2**



**Power Rating and Derating**

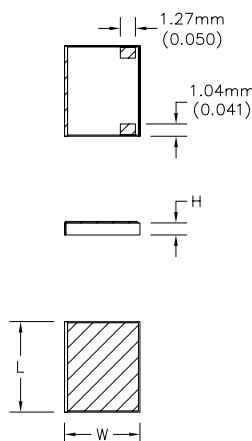


**Alternative Derating Available Upon Request**



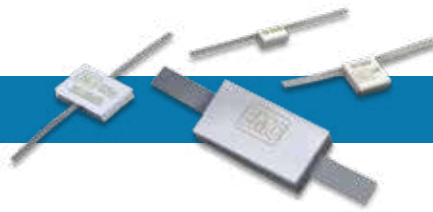
*\*The heat sink is defined as the surface that the Component is attached to, ie. chassis or printed circuit board.*

**Figure 3**

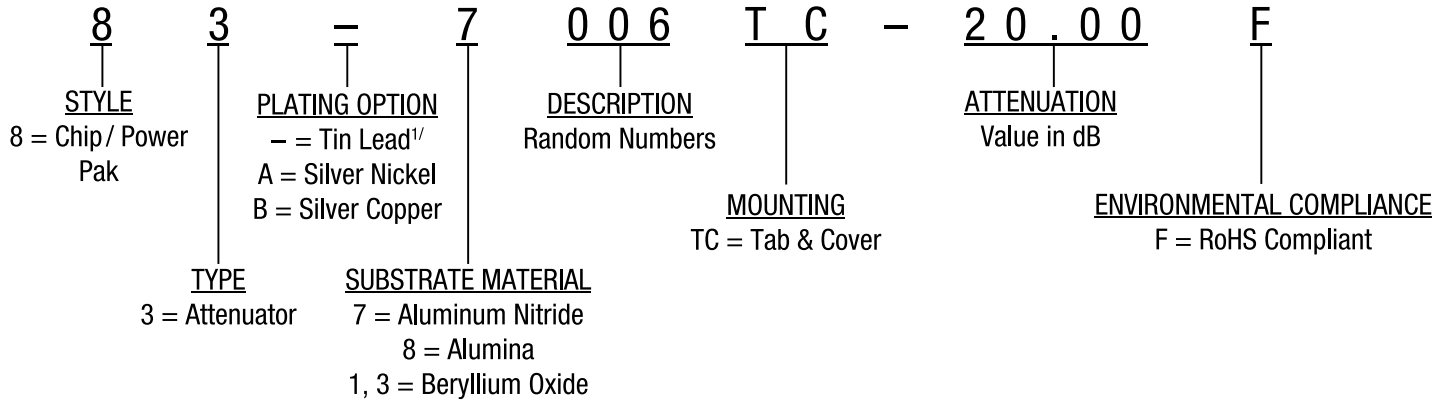


# 83 Series Tab & Cover

## Power Pack Attenuator



### Part Numbering Code



<sup>1/</sup>Not RoHS Compliant

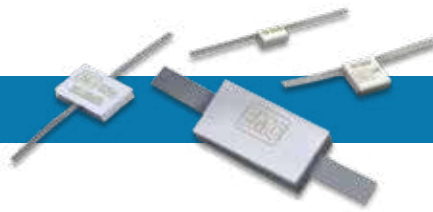
### Product Information Table

Power	Freq	VSWR	Substrate	L		W		H		I		Part Number*	Figure #
	GHz	Max		mm [inches]									
10	4.0	1.35	BeO	5.08	[0.200]	2.54	[0.100]	2.16	[0.085]	1.02	[0.040]	83 3005TC*	1
20	4.0	1.50	BeO	6.35	[0.250]	6.35	[0.250]	2.16	[0.085]	1.52	[0.060]	83 1001TC*	1
20	4.0	1.50	BeO	5.08	[0.200]	2.54	[0.100]	2.16	[0.085]	1.02	[0.040]	83 3001TC*	1
50	2.5	1.40	BeO	9.53	[0.375]	9.53	[0.375]	2.16	[0.085]	1.52	[0.060]	83 3021TC*	1
50	2.0	1.25	BeO	6.35	[0.250]	9.53	[0.375]	1.02	[0.040]	1.02	[0.040]	83 1996TC* /2	3
70	2.8	1.25	AlN	6.35	[0.250]	9.53	[0.375]	2.16	[0.085]	1.02	[0.040]	83 7009TC* /1	1
70	2.0	1.35	BeO	9.53	[0.375]	9.53	[0.375]	2.16	[0.085]	1.52	[0.060]	83 3997TC* /2	4
75	2.0	1.20	AlN	6.35	[0.250]	9.53	[0.375]	2.16	[0.085]	1.02	[0.040]	83 7011TC* /1 /2	2
100	2.3	1.20	AlN	5.84	[0.230]	8.89	[0.350]	2.16	[0.085]	1.02	[0.040]	83 7023TC*	5
100	2.3	1.15	AlN	5.84	[0.230]	8.89	[0.350]	2.16	[0.085]	1.02	[0.040]	83 7017TC*	6
100	3.0	1.30	AlN	6.35	[0.250]	9.53	[0.375]	2.16	[0.085]	1.02	[0.040]	83 7006TC*	5
100	0.8	1.25	BeO	12.70	[0.500]	12.70	[0.500]	2.16	[0.085]	1.52	[0.060]	83 1003TC*	1
150	1.0	1.50	BeO	9.53	[0.375]	9.53	[0.375]	2.16	[0.085]	1.52	[0.060]	83 1006TC*	1
150	2.2	1.40	AlN	6.35	[0.250]	9.53	[0.375]	2.16	[0.085]	1.02	[0.040]	83 7034TC*	6
150	3.0	1.30	AlN	7.62	[0.300]	11.43	[0.450]	1.91	[0.075]	1.02	[0.040]	83 7008TC* /1 /2	3
150	2.0	1.30	BeO	6.35	[0.250]	9.53	[0.375]	2.16	[0.085]	1.02	[0.040]	83 3016TC* /1 /2	5
150	1.0	1.50	BeO	9.53	[0.375]	9.53	[0.375]	2.16	[0.085]	1.52	[0.060]	83 3006TC* /1 /2	1
250	1.0	1.25	BeO	12.70	[0.500]	12.70	[0.500]	2.16	[0.085]	1.52	[0.060]	83 3994TC* /1 /2	4

\* is a place holder. See part number configurations to complete the part number.

/1 only available in 20dB

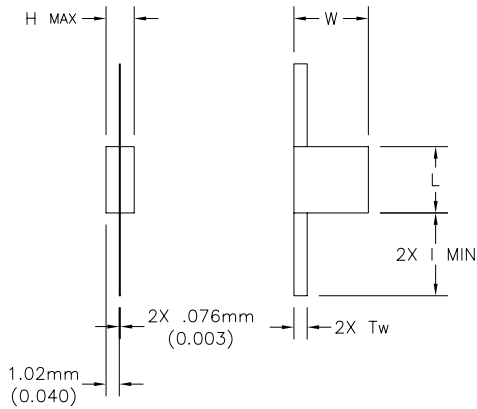
/2 only available in 30dB



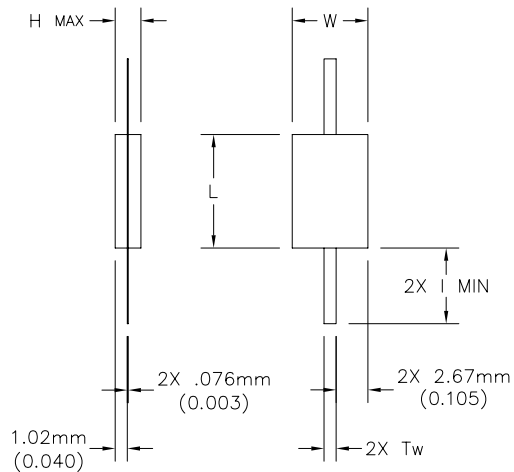
## 83 Series Tab & Cover

Power Pack Attenuator

**Figure 1**



**Figure 2**



Tab & Cover devices are flangeless with protective ceramic covers and tab contacts, offering the highest performance available of any package style component. They are designed for direct solder attachment to a heat sink for excellent heat transfer. The tab and cover attenuators have attenuation range from 1 dB to 30 dB. Typical attenuation tolerance for values between 1-10 db is +/- 0.5 dB and 11-30 dB is +/- 1.0 dB (may vary for certain products please refer to drawing). All devices are made compliant to RoHS.

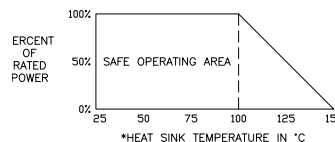
### Features

- Substrates - BeO, AlN, and Alumina
- Highest Performance
- Direct Attachment
- Attenuation Values from 0 to 30 dB
- Single Tab and Double Tab Configurations
- Many Finishes Available

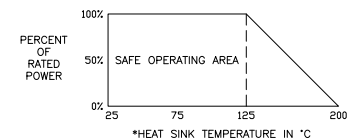
### Specifications

Impedance	50 Ohms
Frequency Range	DC to 4 GHz
Attenuation Accuracy	±0.5 dB
VSWR (Typical)	1.30 @ 1 GHz
Power Rating	10 - 250 Watts
Operating Temperature	-55°C to 150°C
Substrate	Alumina, BeO or AlN
Resistive Material	Thin Film
Tab Contact	Different Finishes Available

### Power Rating and Derating



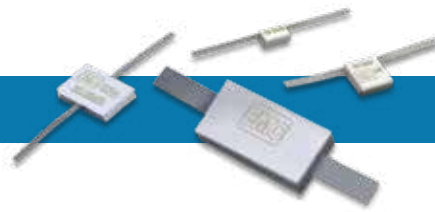
### Alternative Derating Available Upon Request



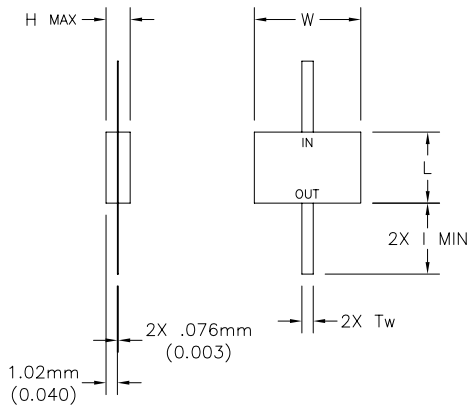
\*The heat sink is defined as the surface that the Component is attached to, ie. chassis or printed circuit board.

# 83 Series Tab & Cover

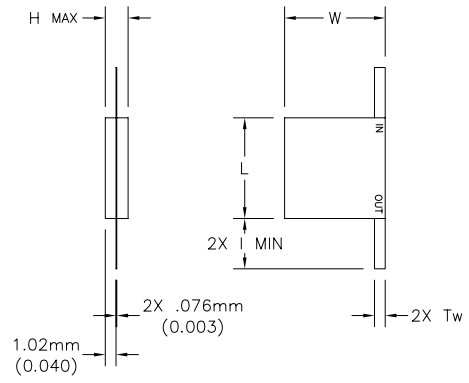
## Mechanical Outlines



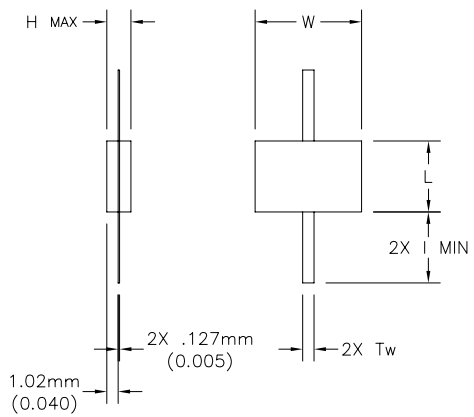
**Figure 3**



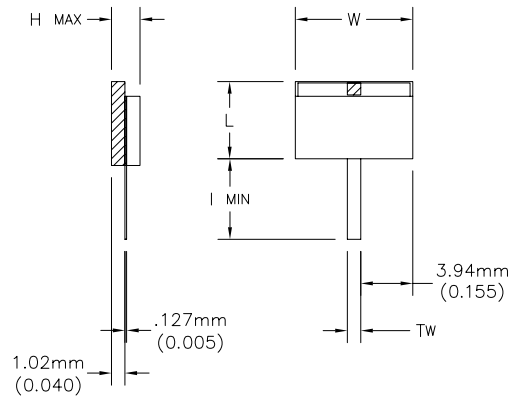
**Figure 4**



**Figure 5**



**Figure 6**

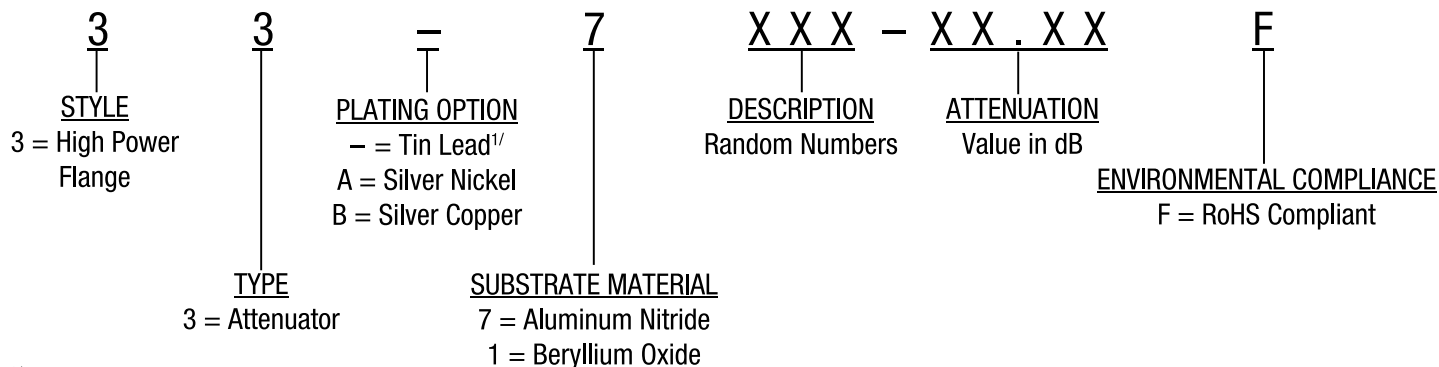




## 33 Series Flange

High Power Attenuator

### Part Numbering Code



<sup>1/</sup>Not RoHS Compliant

### Product Information Table

Power	Freq	VSWR	Substrate	L		W		H		TW		Part Number*	Figure #
	GHz	Max		mm [inches]									
10	2.7	1.15	AlN	5.08	[0.200]	7.62	[0.300]	3.81	[0.150]	1.02	[0.040]	33 7003*	1
10	0.9	1.25	BeO	5.08	[0.200]	7.62	[0.300]	3.81	[0.150]	1.02	[0.040]	33 1041*	1
10	4.0	1.35	BeO	5.08	[0.200]	12.70	[0.500]	3.81	[0.150]	1.02	[0.040]	33 1017*	2
10	4.0	1.35	BeO	5.08	[0.200]	7.62	[0.300]	3.81	[0.150]	1.02	[0.040]	33 1005*	1
20	4.0	1.50	BeO	6.35	[0.250]	13.08	[0.515]	3.81	[0.150]	1.52	[0.060]	33 1001*	3
50	2.5	1.40	BeO	9.53	[0.375]	24.77	[0.975]	5.33	[0.210]	1.52	[0.060]	33 1021*	4
50	2.0	1.40	AlN	9.53	[0.375]	24.77	[0.975]	5.33	[0.210]	1.50	[0.059]	33 7002* /1	4
50	2.0	1.40	AlN	9.53	[0.375]	24.77	[0.975]	5.33	[0.210]	1.52	[0.060]	33 7001* /1	4
50	1.0	1.20	BeO	9.53	[0.375]	24.77	[0.975]	5.33	[0.210]	1.52	[0.060]	33 1002*	4
75	2.2	1.20	AlN	9.53	[0.375]	22.10	[0.870]	3.81	[0.150]	1.02	[0.040]	33 7005*	5
75	1.0	1.30	BeO	9.53	[0.375]	22.10	[0.870]	3.81	[0.150]	1.02	[0.040]	33 1009*	5
100	2.5	1.20	AlN	5.84	[0.230]	20.32	[0.800]	3.81	[0.150]	1.02	[0.040]	33 7023*	7
100	3.0	1.30	AlN	6.48	[0.255]	20.83	[0.820]	4.06	[0.160]	1.02	[0.040]	33 7004*	8
100	0.8	1.25	BeO	12.70	[0.500]	31.75	[1.250]	5.33	[0.210]	1.52	[0.060]	33 1003*	6
100	2.5	1.20	AlN	5.84	[0.230]	20.32	[0.800]	3.81	[0.150]	1.02	[0.040]	33 7023*	7
150	1.0	1.50	BeO	9.53	[0.375]	24.77	[0.975]	5.33	[0.210]	1.52	[0.060]	33 1006*	4
200	0.5	1.50	BeO	26.42	[1.040]	48.26	[1.900]	6.22	[0.245]	6.35	[0.250]	33 1004*	9
250	1.0	1.25	BeO	12.70	[0.500]	31.75	[1.250]	5.33	[0.210]	1.52	[0.060]	33 1042* /2	6
250	1.0	1.25	BeO	12.70	[0.500]	31.75	[1.250]	5.33	[0.210]	1.52	[0.060]	33 1052*	6
400	1.0	1.30	BeO	12.70	[0.500]	31.75	[1.250]	5.33	[0.210]	1.52	[0.060]	33 1050*	10

\* is a place holder. See part number configurations to complete the part number.

/1 only available in 20 dB

/2 only available in 30 dB

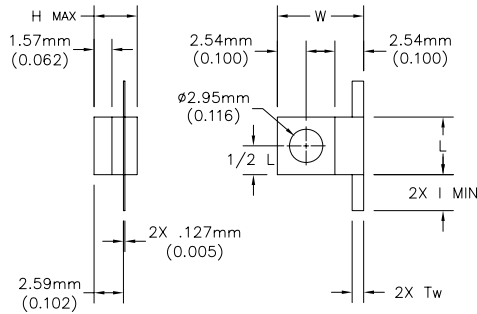
"1 min" dimension = 3.18 mm [0.125]

# 33 Series Flange

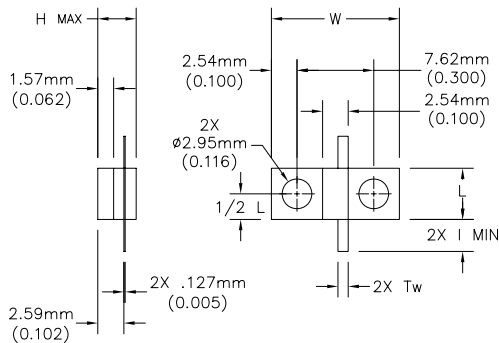
## High Power Attenuator



**Figure 1**



**Figure 2**

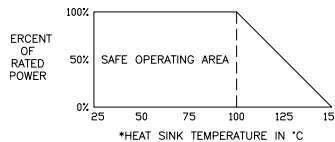


High power flange mount components offer high performance and the convenience of bolt-on installation. Flange attenuators have an attenuation range from 1 to 30 dB. Typical attenuation tolerance for values between 1-10 dB is +/- 0.5 dB and between 11-30 dB is +/- 1.0 dB (may vary for certain products, please refer to drawing). Maximum power rating of up to 400 watts can be achieved on a single device. All devices can be made RoHS compliant and available in Aluminum Nitride (AlN) or BeO.

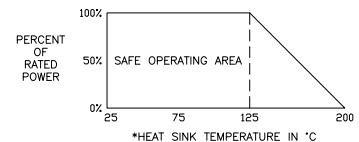
### Specifications

Impedance	50 Ohms
Frequency Range	DC to 4 GHz
VSWR (Typical)	1.30
Power Rating	10 to 400 Watts
Operating Temperature	-55°C to 150°C
Substrate	BeO or AlN
Resistive Material	Nichrome
Tab Contact	Different Finishes Available
Cover	Alumina
Flange	Copper, Nickel Plated

### Power Rating and Derating



### Alternative Derating Available Upon Request



\*The heat sink is defined as the surface that the Component is attached to, ie. chassis or printed circuit board.

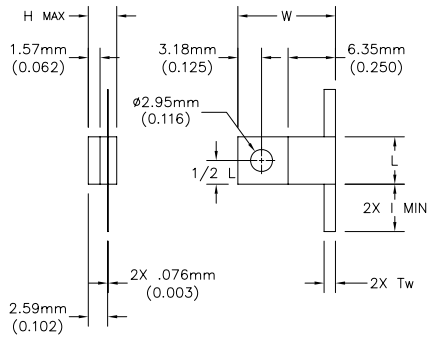




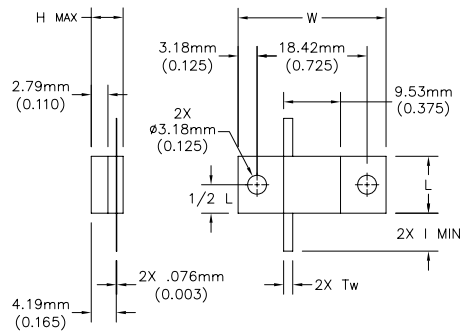
# 33 Series Flange

## Mechanical Outlines

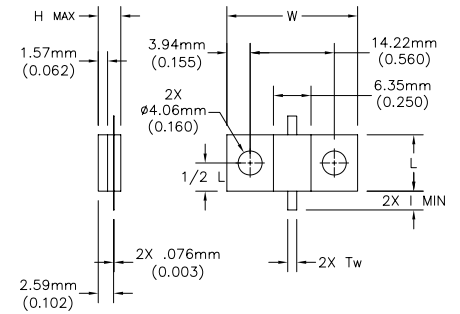
**Figure 3**



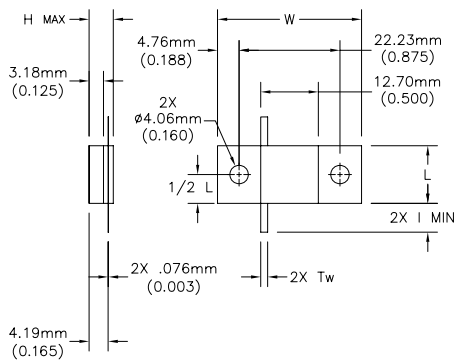
**Figure 4**



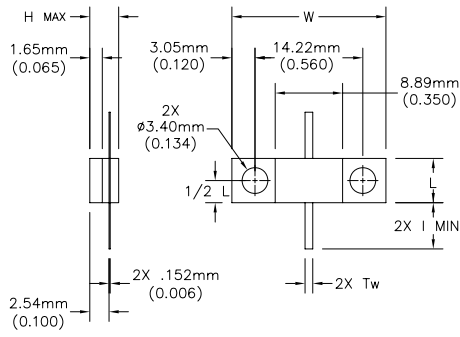
**Figure 5**



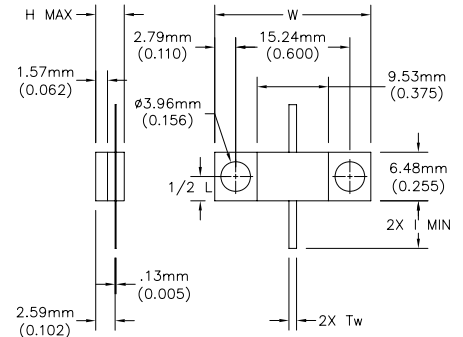
**Figure 6**



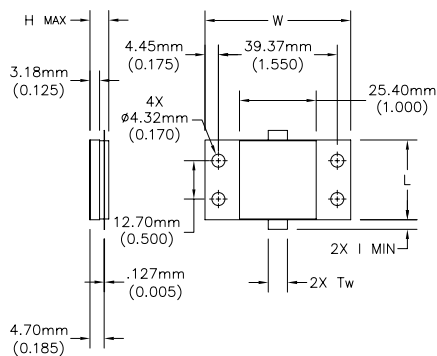
**Figure 7**



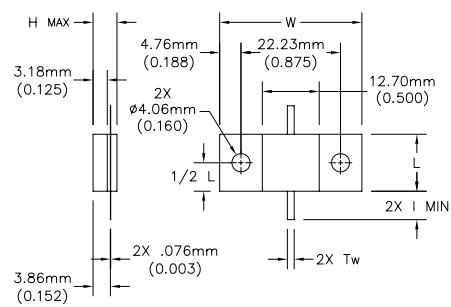
**Figure 8**



**Figure 9**

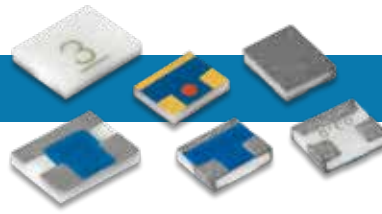


**Figure 10**



# HR05 (18.0 GHz)

## High Reliability Chip Attenuator

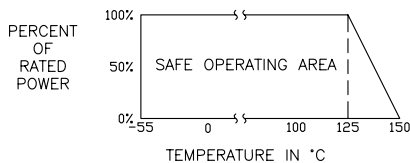


EMC Technology's miniature size attenuators with extended broadband frequency operation from DC to 18 GHz are available tested based on Mil-PRF-55342 for high reliability applications. Simply choose the testing level you require by selecting Group A, B, or C. The product is rated for 100 milliwatts of input power with attenuation values from 0 dB to 20 dB. The space-approved thin film tantalum nitride (TaN) resistive elements offer superior electrical performance and mechanical integrity. The devices are shipped in serialized waffle packaging with tested samples marked and packaged separately and includes serialized test data.

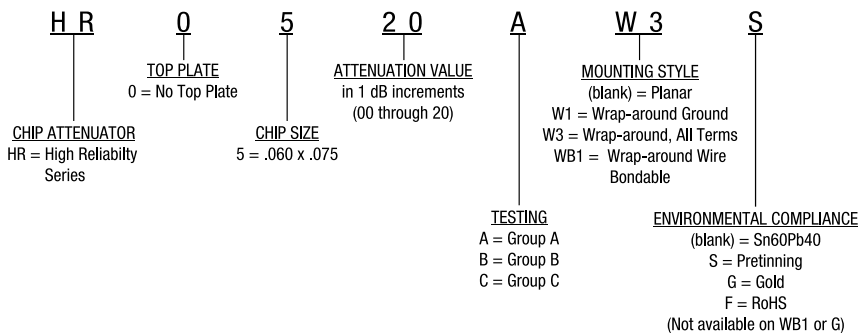
### Specifications

Size	1.52mm x 1.91mm [0.060in x 0.075in]
Impedance	50 Ohms
Frequency Range	Planar Series DC to 18 GHz W Series DC to 12.4 GHz
VSWR (Typical)	1.30
Power Rating	100 Milliwatts
Operating Temperature	-55°C to 150°C
Substrate	Alumina
Resistive Material	Thin Film
Terminal Material	Thick Film, Nickel Barrier with Solder Plated or RoHS, Gold and Wire Bondable options available

### Power Rating and Derating

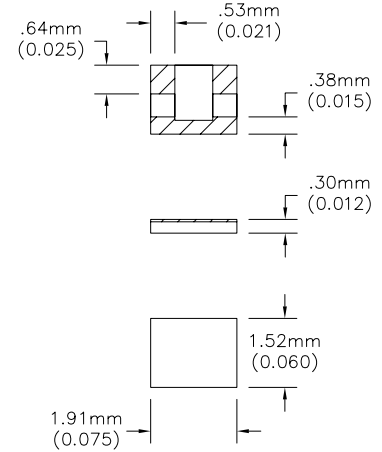


### Part Numbering Code

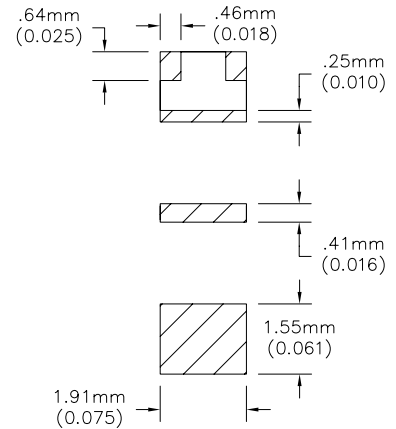


See page 105 for test plan.

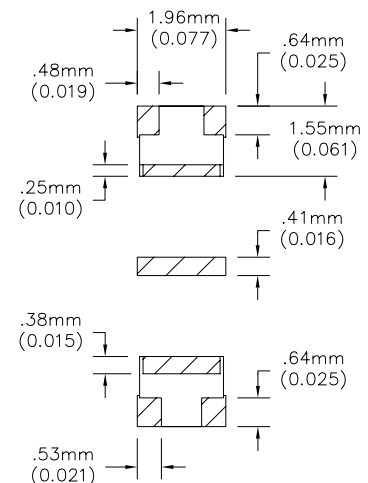
### HR05 Planar Series

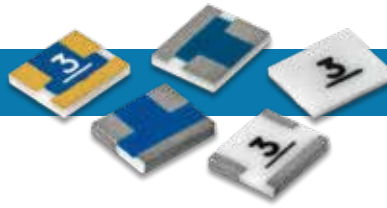


### HR05 Single Wrap Series



### HR05 Triple Wrap Series

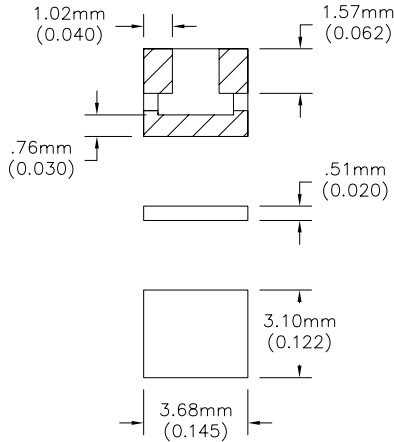




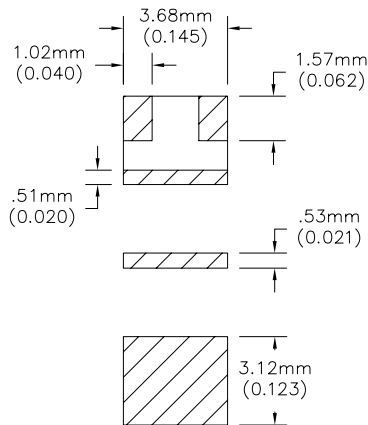
# HR03 (12.4 GHz)

## High Reliability Chip Attenuator

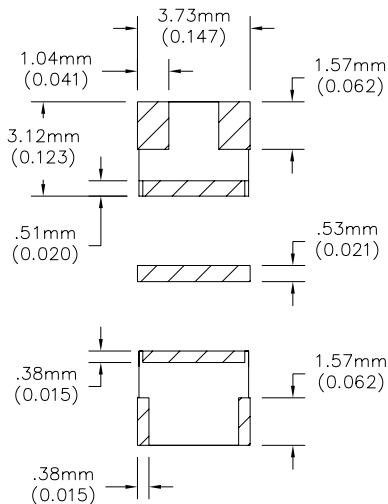
### HR03 Planar Series



### HR03 Single Wrap Series



### HR03 Triple Wrap Series

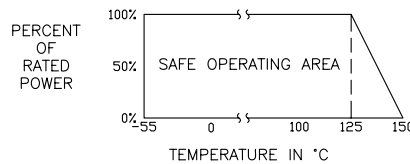


EMC Technology's attenuators are available tested based on Mil-PRF-55342 for high reliability applications. Simply choose the testing level you require by selecting Group A, B, or C. The product is rated for 2 watts input power with attenuation values from 0 dB to 20 dB and a maximum operating frequency of 12.4 GHz. The space-approved thin film tantalum nitride (TaN) resistive elements offer superior electrical performance and mechanical integrity. The devices are shipped in serialized waffle packaging with tested samples marked and packaged separately and includes serialized test data.

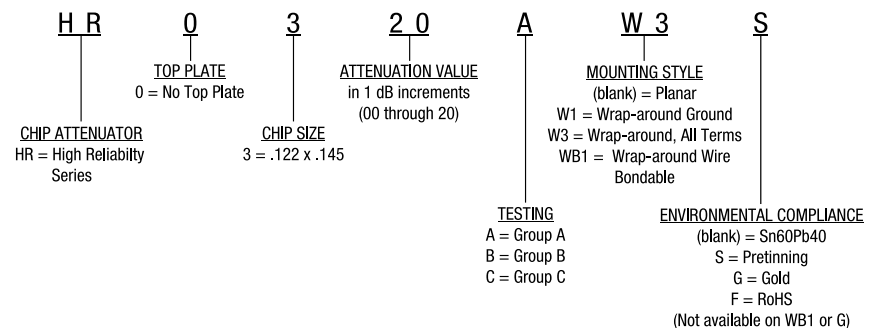
### Specifications

Size	3.10mm x 3.68mm [0.122in x 0.145in]
Impedance	50 Ohms
Frequency Range	Planar Series DC to 12.4 GHz W Series DC to 8 GHz
VSWR (Typical)	1.30
Power Rating	2.0 Watts
Operating Temperature	-55°C to 150°C
Substrate	Alumina
Resistive Material	Thick Film
Terminal Material	Thick Film, Nickel Barrier with Solder Plated or RoHS, Gold and Wire Bondable Options Available

### Power Rating and Derating



### Part Numbering Code



See page 101 for test plan.

# 42 Series (18.0 GHz)

## Coaxial SMA Attenuator



Bridging the gap between EMC Technology components and Florida RF Labs cable assemblies, our line of precision coaxial attenuators offer an easy to use attenuation solution for applications with up to 2 watts of input power. The rugged construction of the device ensures reliability and uninterrupted high performance with operating frequencies up to 40 GHz.

### Features

- Rugged Construction
- Excellent Performance
- Value Pricing
- Subsystem Connector Interface
- SMA & 2.92mm

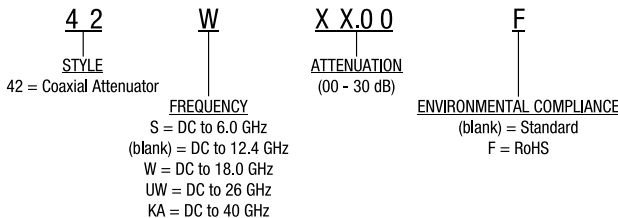
### General Specifications

Impedance	Power	Operating Temperature	Pins	Body & Nut
50 Ohms	2 Watts	-55°C to +150°C	Beryllium Copper, Gold Plated	Stainless Steel, Passivated

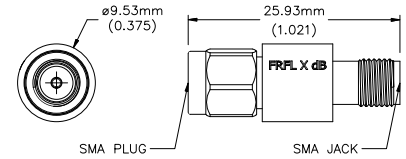
### Series Specifications

Series	Frequency Range	Connector	VSWR ( Max)
42S	DC to 6.0 GHz	SMA Male/Female	1.35
42	DC to 12.4 GHz	SMA Male/Female	1.30
42W	DC to 18.0 GHz	SMA Male/Female	1.35
42UW	DC to 26 GHz	SMA Male/Female	1.50
42KA	DC to 40 GHz	2.92 Male/Female	1.40

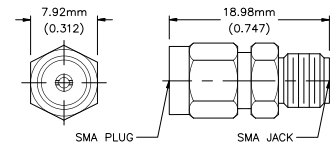
### Part Numbering Code



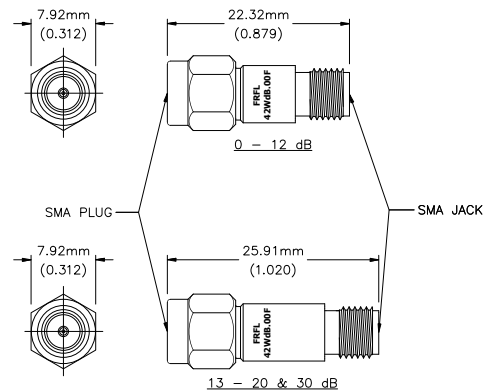
### 42S Series



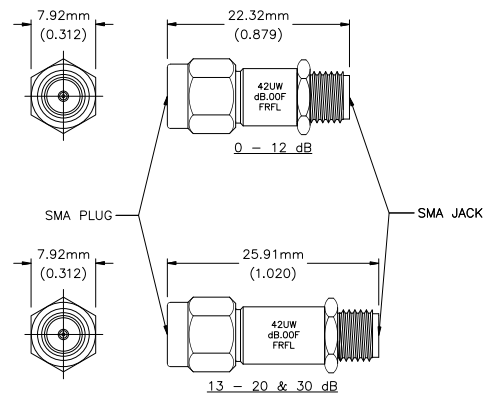
### 42 Series



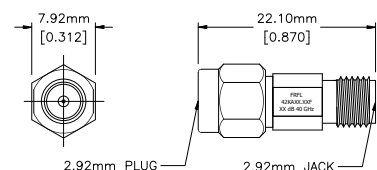
### 42W Series



### 42UW Series



### 42KA Series



### Features

- Frequency Range from DC to 26 GHz
- Power Handling up to 1000 Watts
- BeO, ALN, Alumina or CVD Diamond Substrates
- Telecom Tuned Circuit Designs Available
- Tin/Lead, Lead Free, or Solder Fused Plated
- Tape and Reel Packaging Available
- High Reliability Versions Available
- Tab & Cover, Flange-Mounted, Threaded, Stripline Flange, Pill, Coaxial Remote (CRT), Surface Mount and Wire-Bondable
- S-Parameter Data Available

### Applications

- Broadcast (TV and Radio)
- High Power Amplifier
- High Power Filters
- Instrumentation
- Isolators
- Military
- Remote Termination
- Satellite Communication
- Splitters / Combiners

For our CVD Diamond Terminations see **Diamond Rf Resistives®** on pages 65 to 74



We offer a full line of high power RF terminations including styles such as: chip, tab & cover, flange-mounted coaxial, SMA, stripline flange, surface mount and wire-bondable. Our tuned circuit chip designs deliver the lowest VSWR, while extending frequency ranges for broadband applications. Some devices are capable of handling power up to 1KW and frequencies up to 26.5 GHz. Our products are offered in different substrates such as: Alumina, BeO, AlN and CVD diamond.

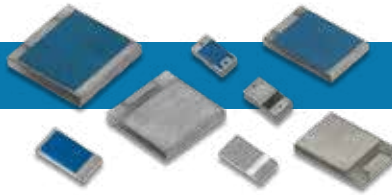
### Quick Selector Chart

Style	Frequency (GHz)	Power (Watts)	Page
Chip SMT Series	DC - 4	10 - 150	38-39
Chip CT Series	DC - 26.5	2 - 250	40-41
Tab & Cover 82 Series	DC - 18	10 - 500	42-43
Flange 32 Series	DC - 18	10 - 1000	44-49
Flange 5 Series	DC - 2	10 - 250	44-49
Stripline Flange 8 Series	DC - 26.6	1 - 75	50-52
Coaxial (Soldered) 12 Series	DC - 26.6	0.5	53-54
Coaxial (Solderless) 41 Series	DC - 18	2	53-54

\*Maximum Power

# SMT Series

## Surface Mount Terminations

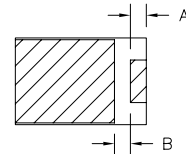
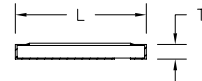
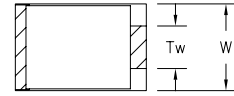


We offer a wide selection of SMT chip terminations handling input power levels up to 250W and covering frequency ranges up to 4 GHz. Using EMC's patented asymmetrical wrap geometry, the thermal dissipation of the surface mount termination is improved by increasing the solderable grounding area. This eliminates the need for bolt down heat sinks and tabs, thereby reducing assembly costs.

### Specifications

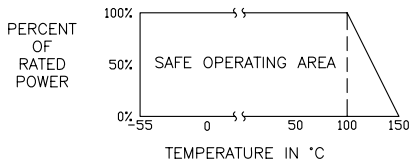
Impedance	50 Ohms
Frequency Range	DC to 4 GHz
Power Rating	100% @ 100 °C
Derates to	0% @ 150 °C
Operating Temperature	-55 °C to 150 °C
Resistive Material	Thick Film
Terminal Material	Thick Film, Nickel Barrier, Solder or no lead Silver Plated Finish

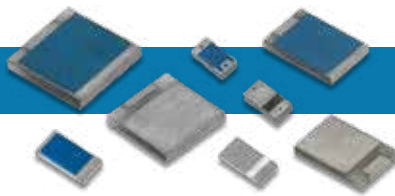
### SMT



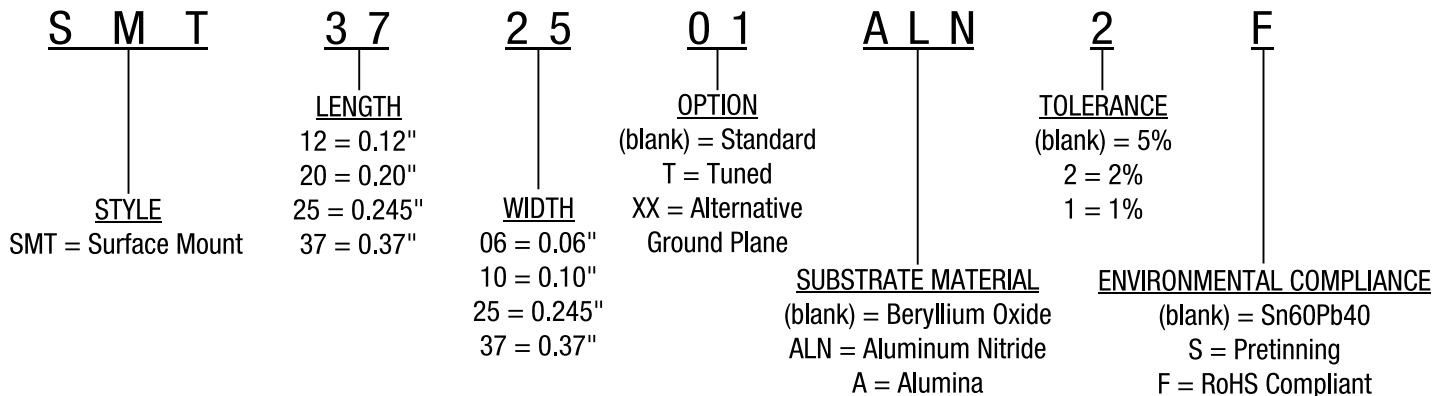
For A, B and Tw dimensions see data sheet on website.

### Power Rating and Derating





**Part Numbering Code**



Power	Frequency	VSWR	Substrate	L		W		T		Part Series #
Watt	GHz	Max:1		mm	[inches]	mm	[inches]	mm	[inches]	
10	2.0	1.25	AlN	3.04	[0.120]	1.52	[0.060]	0.68	[0.027]	SMT1206 *ALN
10	3.0	1.25	Alumina	5.08	[0.200]	2.54	[0.100]	0.64	[0.025]	SMT2010*A
15	3.0	1.25	Alumina	6.35	[0.250]	6.35	[0.250]	1.04	[0.041]	SMT2525*A
20	4.0	1.20	AlN	5.08	[0.200]	2.54	[0.100]	0.64	[0.025]	SMT2010TALN
20	2.0	1.25	AlN	5.08	[0.200]	2.54	[0.100]	1.04	[0.041]	SMT2010*ALN
20	3.0	1.25	Alumina	9.40	[0.370]	6.35	[0.250]	0.64	[0.025]	SMT3725*A
25	3.0	1.25	Alumina	9.53	[0.375]	9.52	[0.375]	0.64	[0.025]	SMT3737*A
30	2.0	1.25	BeO	5.08	[0.200]	2.54	[0.100]	1.04	[0.041]	SMT2010
60	2.0	1.25	AlN	6.35	[0.250]	6.35	[0.250]	1.04	[0.041]	SMT2525*ALN
60	2.7	1.15	AlN	6.35	[0.250]	6.35	[0.250]	1.04	[0.041]	SMT2525TALNF
75	2.0	1.25	BeO	6.35	[0.250]	6.35	[0.250]	1.04	[0.041]	SMT2525
80	2.7	1.15	AlN	9.53	[0.375]	6.35	[0.250]	1.04	[0.041]	SMT3725TALN
80	2.0	1.25	AlN	9.53	[0.375]	6.35	[0.250]	1.04	[0.041]	SMT3725*ALN
100	2.7	1.15	AlN	9.40	[0.372]	9.40	[0.372]	1.30	[0.051]	SMT3737TALN
100	2.0	1.25	AlN	9.40	[0.372]	9.40	[0.372]	1.30	[0.051]	SMT3737*ALN
125	2.0	1.25	BeO	9.53	[0.375]	6.35	[0.250]	1.04	[0.041]	SMT3725
150	2.0	1.25	BeO	9.40	[0.372]	9.40	[0.372]	1.30	[0.051]	SMT3737
150	4.0	1.20	AlN	6.35	[0.250]	6.35	[0.250]	1.04	[0.041]	SMT252503ALN2F
200	2.7	1.20	AlN	9.40	[0.370]	6.22	[0.245]	1.04	[0.041]	SMT372503ALN2F

"F" suffix (RoHS) is not available with Pretinning ("S" suffix)

\*\*\* Is a place holder. See part number configurations to complete the part number

# CT High Power Series

## Chip Termination

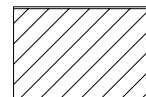
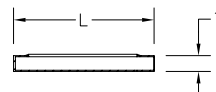
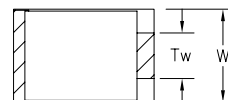


Our high power chip terminations are available in both thick film and thin film resistor designs, offering you flexibility needed to match the correct part more closely to your specific application. Many designs have been optimized for RF performance and so will minimize the variability of capacitive reactance. Localized hot spots associated with trimming have been virtually eliminated. Reduced variation means your circuit performs so consistently that in most cases no external tuning is required.

### Specifications

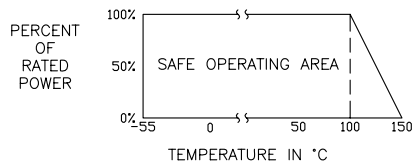
Impedance	50 Ohms
Frequency Range	DC to 26.5 GHz
Power Rating	100% @ 100°C
Derates to	0% @ 150 °C
Operating Temperature	-55 °C to 150 °C
Resistive Material	Thick Film
Terminal Material	Thick Film, Nickel Barrier, Solder, Silver (RoHS) or Gold

### CT

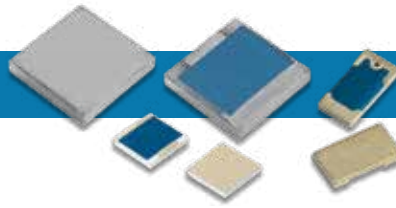


For Tw dimensions see data sheet on website.

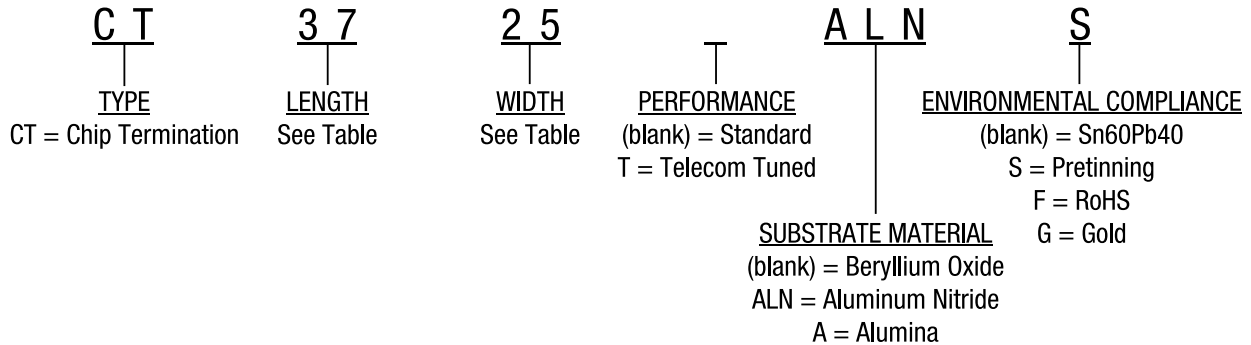
### Power Rating and Derating







### Part Numbering Code



*Note: Not every combination of size is available.  
Other ohms values available upon request. Please contact our Sales department.  
"F" and "G" suffixes not available with pretinning ("S" suffix).*

Power Watt	Frequency GHz	VSWR Max:1	Substrate	L		W		T		Part Series #
					mm [inches]		mm [inches]		mm [inches]	
1	26.50	1.35	BeO	1.02	[0.040]	0.51	[0.020]	0.28	[0.011]	CT0402
2	2.50	1.25	Alumina	2.54	[0.100]	1.27	[0.050]	.028	[0.011]	CT1005*A
5	2.00	1.25	Alumina	5.08	[0.200]	2.54	[0.100]	1.04	[0.041]	CT2010*A
10	4.00	1.25	BeO	1.27	[0.050]	1.27	[0.050]	0.28	[0.011]	CT0505
10	2.00	1.25	BeO	3.05	[0.120]	1.53	[0.060]	0.64	[0.025]	CT1206
15	4.00	1.25	BeO	2.54	[0.100]	1.27	[0.050]	0.28	[0.011]	CT1005
15	4.00	1.10	AlN	2.54	[0.100]	1.27	[0.050]	0.28	[0.011]	CT1005TALN
15	4.00	1.25	AlN	3.05	[0.120]	1.53	[0.060]	0.64	[0.025]	CT1206*ALN
20	4.00	1.25	BeO	5.08	[0.200]	2.54	[0.100]	1.04	[0.041]	CT2010
20	4.00	1.25	AlN	5.08	[0.200]	2.54	[0.100]	1.04	[0.041]	CT2010*ALN
20	2.00	1.25	Alumina	4.57	[0.180]	8.89	[0.350]	0.64	[0.025]	CT1835*A
30	4.00	1.25	AlN	6.35	[0.250]	6.35	[0.250]	1.04	[0.041]	CT2525*ALN
50	4.00	1.25	BeO	6.35	[0.250]	6.35	[0.250]	1.04	[0.041]	CT2525
80	4.00	1.25	AlN	5.82	[0.230]	8.89	[0.350]	1.04	[0.041]	CT2335*ALN
90	2.00	1.30	Alumina	5.82	[0.230]	8.89	[0.350]	0.38	[0.015]	CT2335*A
100	4.00	1.25	BeO	5.82	[0.230]	8.89	[0.350]	1.04	[0.041]	CT2335
100	2.50	1.30	AlN	6.35	[0.250]	6.35	[0.250]	1.04	[0.041]	CT2525TALN
120	3.00	1.10	AlN	5.82	[0.230]	8.89	[0.350]	1.04	[0.041]	CT2335TALN
150	2.00	1.25	AlN	9.40	[0.370]	6.35	[0.250]	1.04	[0.041]	CT3725*ALN
150	2.00	1.25	BeO	9.40	[0.370]	6.35	[0.250]	1.04	[0.041]	CT3725
150	2.00	1.25	BeO	9.40	[0.370]	6.35	[0.250]	1.04	[0.041]	CT3725F
200	2.00	1.20	AlN	9.53	[0.375]	9.52	[0.375]	1.30	[0.051]	CT3737TALN
250	2.00	1.35	BeO	9.53	[0.375]	9.52	[0.375]	1.30	[0.051]	CT3737

Power ratings are based on 100°C heat sink, except for CT2335A, which is 85°C

"\*" is a place holder. See part number configurations to complete the part number

## 82 Series

### Tab & Cover



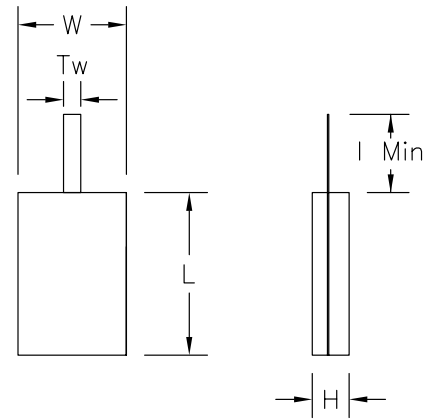
Tab and cover terminations are flangeless devices with protective ceramic covers and tab contacts, offering the highest performance available of any style of component. They are designed for direct solder attachment to a heat sink or circuit board (thermal via required) for excellent heat transfer. These devices deliver excellent VSWR over a broad frequency band. The frequency ranges from DC to 18 GHz. The power rating ranges from 10 to 500 watts. Optional lead forming is available on most designs.

### Specifications

Impedance	50 Ohms
Resistance Range	10 to 300 Ohms
Frequency Range	DC to 18 GHz
Power Rating	100% @ 100°C
Derates to	0% @ 150 °C
Operating Temperature	-55 °C to 150 °C*
Substrate	BeO, AlN or Alumina
Resistor	Thin Film
Tab Contact	Beryllium Copper, Tin or Silver Plated
Cover	Alumina
Solderable Ground Plane	See Plating Option

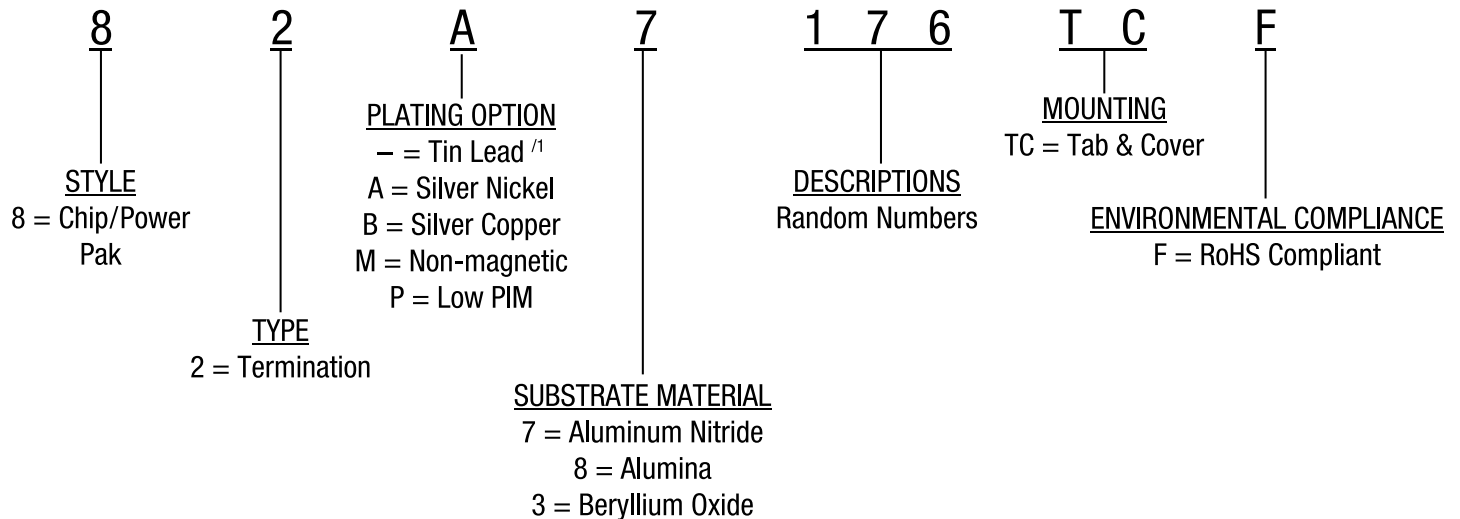
\*100°C is referenced at the heat sink

### TC



"I min" dimension = 3.18 mm [0.125]

### Part Numbering Code



<sup>1</sup> Not RoHS Compliant



## 82 Series

### Product Information

Power	Frequency	VSWR	Substrate	L		W		H		TW		Part Series #
Watt	GHz	Max:1		mm [inches]								
10	2.0	1.18	AlN	5.08	[0.200]	2.54	[0.100]	2.16	[0.085]	0.76	[0.030]	82 7166TC
10	3.0	1.25	AlN	5.08	[0.200]	2.54	[0.100]	2.29	[0.090]	1.02	[0.040]	82 7025TC
10	20.0	1.50	BeO	2.54	[0.100]	5.08	[0.200]	2.29	[0.090]	0.76	[0.030]	82 3056TC
10	18.0	1.65	BeO	2.54	[0.100]	5.08	[0.200]	2.29	[0.090]	1.02	[0.040]	82 3045TC
10	10.0	1.40	BeO	5.08	[0.200]	2.54	[0.100]	2.03	[0.080]	1.02	[0.040]	82 3033TC
10	4.0	1.35	BeO	5.08	[0.200]	2.54	[0.100]	2.29	[0.090]	1.02	[0.040]	82 3001TC
10	4.0	1.35	AlN	5.08	[0.200]	2.54	[0.100]	2.29	[0.090]	2.54	[0.100]	82 7017TC
20	4.0	1.35	BeO	6.35	[0.250]	6.35	[0.250]	2.67	[0.105]	1.52	[0.060]	82 3012TC
30	2.5	1.20	AlN	5.08	[0.200]	2.54	[0.100]	2.16	[0.085]	1.02	[0.040]	82 7004TC
30	2.5	1.20	BeO	3.05	[0.120]	1.53	[0.060]	2.16	[0.085]	0.76	[0.030]	82 3055TC
30	1.0	1.50	BeO	5.84	[0.230]	8.89	[0.350]	2.16	[0.085]	1.02	[0.040]	82 3019TC
30	4.0	1.20	BeO	6.35	[0.250]	6.35	[0.250]	2.16	[0.085]	1.52	[0.060]	82 3005TC
40	2.0	1.20	AlN	6.35	[0.250]	6.35	[0.250]	2.16	[0.085]	0.76	[0.030]	82 7030TC
40	6.0	1.20	BeO	6.35	[0.250]	6.35	[0.250]	2.16	[0.085]	1.02	[0.040]	82 3039TC
40	6.0	1.30	BeO	5.84	[0.230]	8.89	[0.350]	2.16	[0.085]	1.02	[0.040]	82 3030TC
60	4.0	1.20	AlN	6.35	[0.250]	9.52	[0.375]	2.16	[0.085]	0.76	[0.030]	82 7150TC
60	6.0	1.20	BeO	6.35	[0.250]	9.52	[0.375]	2.16	[0.085]	1.52	[0.060]	82 3032TC
60	2.0	1.35	BeO	6.35	[0.250]	6.35	[0.250]	2.16	[0.085]	1.52	[0.060]	82 3003TC
100	4.0	1.20	AlN	6.35	[0.250]	6.35	[0.250]	2.16	[0.085]	0.76	[0.030]	82 7163TC
100	1.0	1.10	AlN	6.35	[0.250]	9.52	[0.375]	2.16	[0.085]	1.02	[0.040]	82 7005TC
100	6.0	1.30	BeO	5.84	[0.230]	8.89	[0.350]	2.16	[0.085]	1.02	[0.040]	82 3038TC
120	2.0	1.20	AlN	5.84	[0.230]	8.89	[0.350]	2.16	[0.085]	0.76	[0.030]	82 7187TC
120	2.0	1.15	AlN	5.84	[0.230]	8.89	[0.350]	2.16	[0.085]	0.76	[0.030]	82 7176TC
120	2.0	1.10	AlN	5.84	[0.230]	8.89	[0.350]	2.16	[0.085]	0.76	[0.030]	82 7015TC
120	2.0	1.10	BeO	5.84	[0.230]	8.89	[0.350]	2.16	[0.085]	1.02	[0.040]	82 3031TC
125	2.7	1.10	AlN	6.35	[0.250]	6.35	[0.250]	2.16	[0.085]	1.52	[0.060]	82 7013TC
150	2.0	1.15	AlN	9.52	[0.375]	6.35	[0.250]	2.16	[0.085]	0.76	[0.030]	82 7172TC
150	2.0	1.15	AlN	9.52	[0.375]	6.35	[0.250]	2.16	[0.085]	1.02	[0.040]	82 7002TC
150	4.0	1.35	BeO	8.89	[0.350]	5.84	[0.230]	2.16	[0.085]	1.02	[0.040]	82 3051TC
150	4.0	1.35	BeO	6.35	[0.250]	9.52	[0.375]	2.16	[0.085]	1.02	[0.040]	82 3023TC
150	1.0	1.35	BeO	6.35	[0.250]	9.52	[0.375]	2.16	[0.085]	3.05	[0.120]	82 3006TC
150	3.0	1.20	AlN	6.22	[0.245]	6.22	[0.245]	1.02	[0.004]	1.02	[0.040]	82 7192TE
250	3.0	1.20	BeO	9.53	[0.375]	6.35	[0.250]	2.24	[0.088]	1.02	[0.040]	82 3213TC
250	2.0	1.50	AlN	9.52	[0.375]	9.52	[0.375]	2.16	[0.085]	1.02	[0.040]	82 7001TC
250	2.0	1.15	BeO	9.52	[0.375]	9.52	[0.375]	2.16	[0.085]	0.76	[0.030]	82 3029TC
250	1.0	1.35	BeO	9.52	[0.375]	9.52	[0.375]	2.16	[0.085]	0.76	[0.030]	82 3008TC
500	1.5	1.35	BeO	12.7	[0.500]	12.70	[0.500]	2.03	[0.080]	1.52	[0.060]	82 3040TC
500	2.5	1.25	BeO	12.7	[0.500]	12.7	[0.500]	1.72	[0.068]	1.52	[0.060]	82 3209TC

Peak power is typically 10 times the max power rating with a 1% duty cycle and 100 microsecond pulse width.

# 32 & 5 Series

## Flange Termination



EMC Technology offers the widest selection of flange mount terminations worldwide. High power flange mount components offer excellent performance and the convenience of bolt-in installation. The flanged mounted devices deliver power ratings up to 1000 watts and frequency ranges from DC to 18 GHz. The packages are available in single hole, double hole and fourhole flange configurations. Tab strain relief is available on all configurations.

We also have a line of flange terminations that offers the lowest Passive *Intermodulation* (PIM) distortion in the market and which are 100% tested to guarantee the highest performance.

Optional lead forming is available.

All devices with the "32" prefix have thin film resistor elements while the part numbers beginning with "5" have thick film resistors.

### Specifications

Impedance	50 Ohms
Resistance Range	10 to 250 Ohms
Frequency Range	DC to 18 GHz
Power Rating	100% to 100°C*
Derates to	0% @ 150 °C
Operating Temperature	-55 °C to 150 °C
Resistor	Thick or Thin Film
Tab Contact	Beryllium Copper, Tin or Silver Plated
Cover	Alumina
Mounting Flange	Copper, Nickel Plated

\*100°C is referenced at the heat sink

### Part Numbering Code

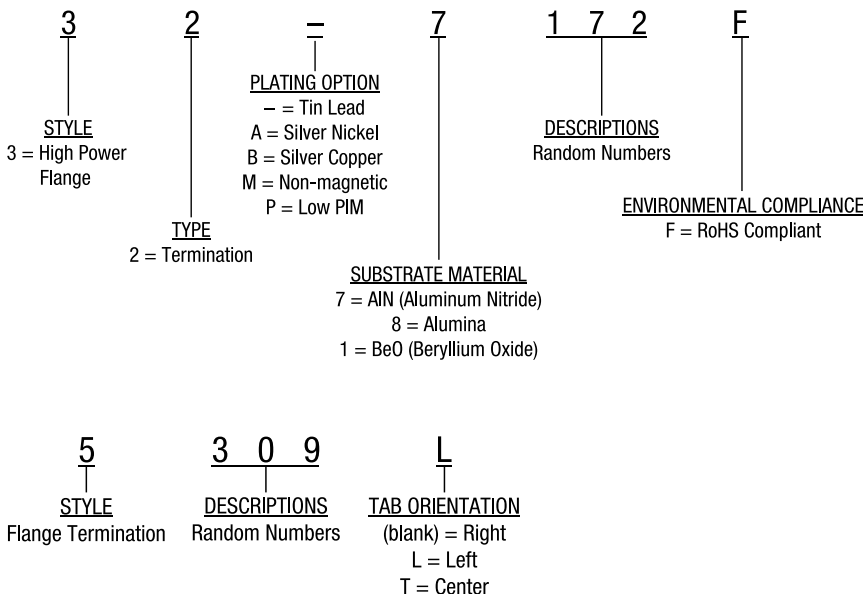


Figure 1L

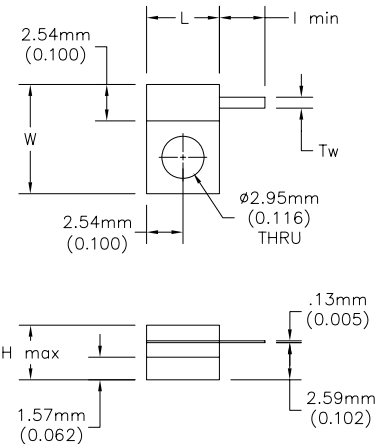


Figure 1C

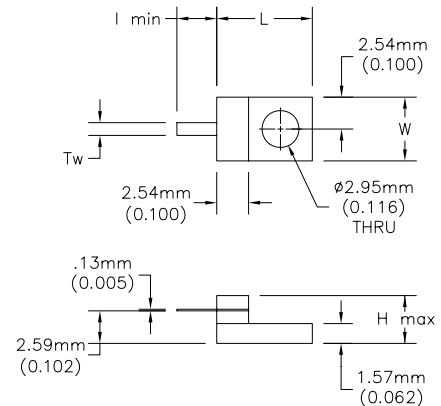


Figure 1R

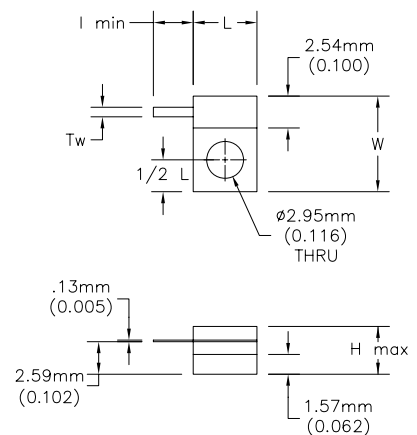




Figure 2L

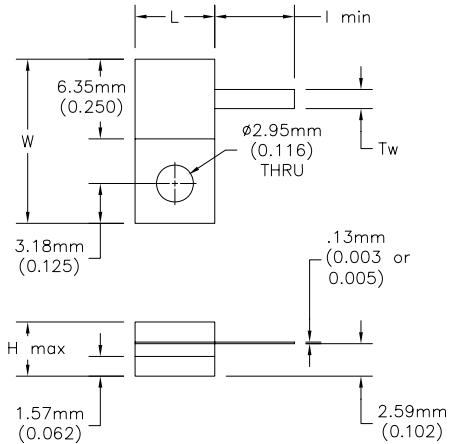


Figure 2C

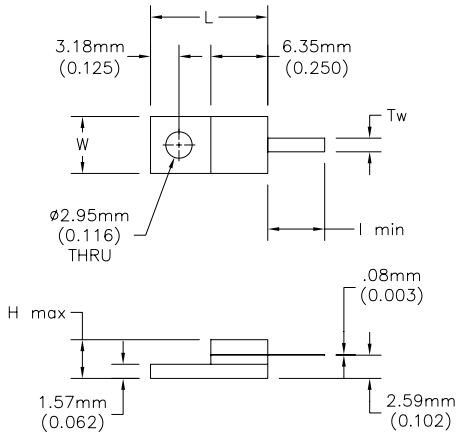


Figure 2R

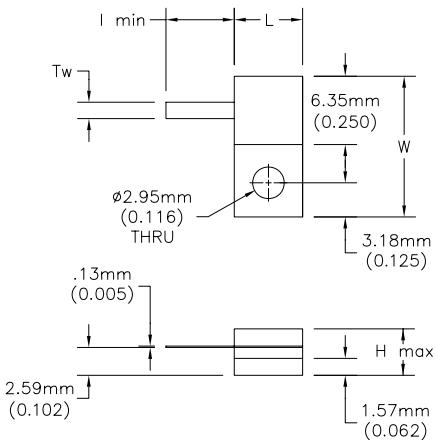


Figure 3

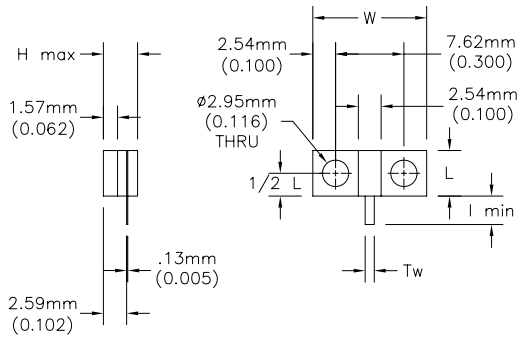


Figure 4

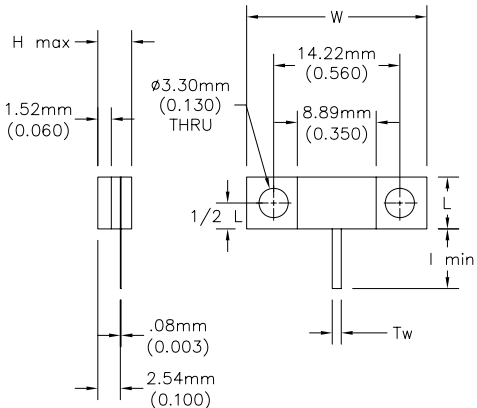
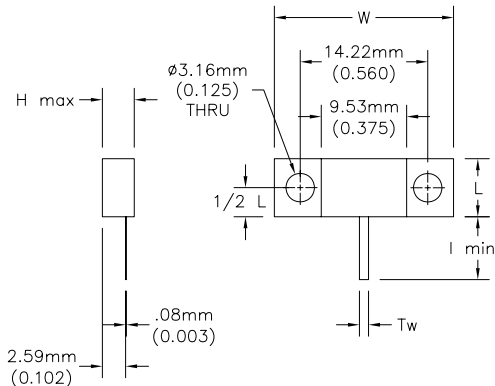


Figure 5

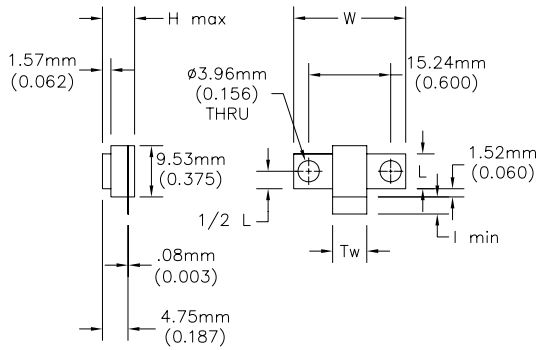


# 32 & 5 Series

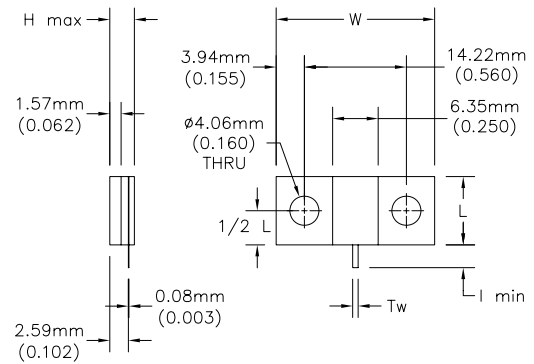
## Mechanical Outlines



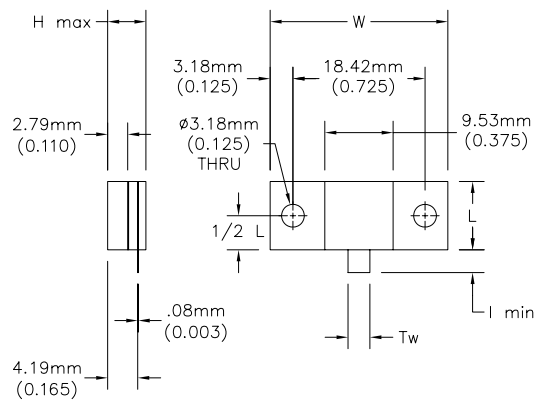
**Figure 6**



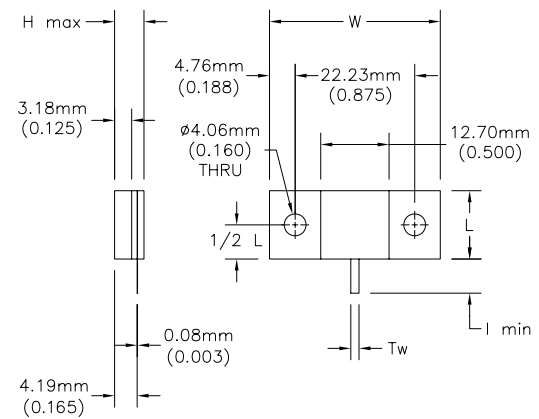
**Figure 7**



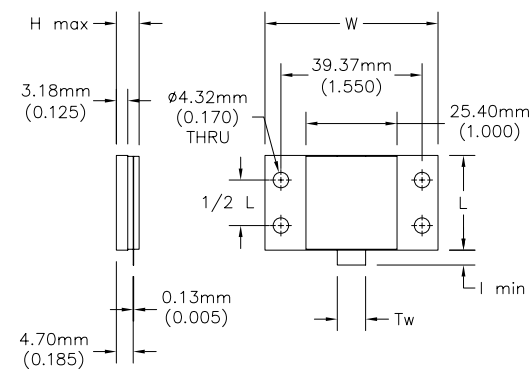
**Figure 8**



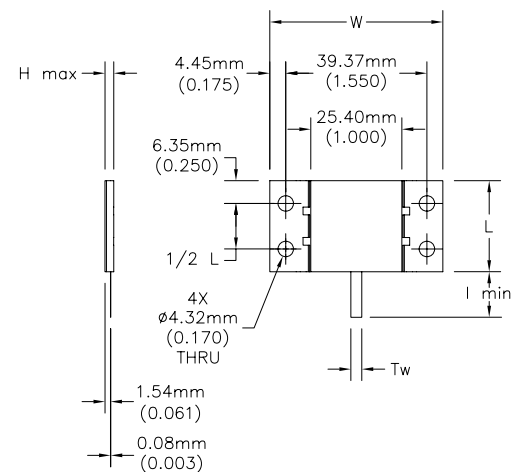
**Figure 9**



**Figure 10**



**Figure 11**





## 32 & 5 Series

### Product Information

Power	Frequency	VSWR	Substrate	L		W		H		TW		Mounting Direction	Part Series #	Figure #
Watt	GHz	Max:1		mm [inches]										
10	18.00	1.60	AlN	7.62	[0.300]	5.08	[0.200]	3.81	[0.150]	0.76	[0.030]	Center	32 7024*	1C
10	6.00	1.25	BeO	7.62	[0.300]	5.08	[0.200]	3.81	[0.150]	1.02	[0.040]	Center	32 1198*	1C
10	18.00	1.50	BeO	7.62	[0.300]	5.08	[0.200]	3.81	[0.150]	1.02	[0.040]	Center	32 1137*	1C
10	10.00	1.40	BeO	5.08	[0.200]	7.62	[0.300]	3.56	[0.140]	1.02	[0.040]	Right	32 1111*	1R
10	10.00	1.40	BeO	5.08	[0.200]	7.62	[0.300]	3.56	[0.140]	1.02	[0.040]	Left	32 1068*	1L
10	4.00	1.35	BeO	5.08	[0.200]	7.62	[0.300]	3.81	[0.150]	1.02	[0.040]	Right	32 1041*	1R
10	4.00	1.35	BeO	5.08	[0.200]	7.62	[0.300]	3.81	[0.150]	1.02	[0.040]	Left	32 1006*	1L
10	4.00	1.35	BeO	12.70	[0.500]	5.08	[0.200]	4.06	[0.160]	1.02	[0.040]	Right	5323*	3
20	2.00	1.35	BeO	6.35	[0.250]	13.08	[0.515]	4.32	[0.170]	1.52	[0.060]	Left	32 1001*	2L
20	2.00	1.35	BeO	13.08	[0.515]	6.35	[0.250]	4.32	[0.170]	1.52	[0.060]	Center	32 1014*	2C
30	4.00	1.20	BeO	6.35	[0.250]	13.08	[0.515]	3.56	[0.140]	1.52	[0.060]	Right	32 1039*	2R
30	4.00	1.25	BeO	13.08	[0.515]	6.35	[0.250]	3.56	[0.140]	1.52	[0.060]	Center	32 1035*	2C
30	4.00	1.25	BeO	6.35	[0.250]	13.08	[0.515]	3.56	[0.140]	1.52	[0.060]	Left	32 1034*	2L
30	4.00	1.25	BeO	6.35	[0.250]	13.08	[0.515]	3.81	[0.150]	1.52	[0.060]	Left	32 1050*	2L
30	4.00	1.25	BeO	6.35	[0.250]	13.08	[0.515]	3.81	[0.150]	1.52	[0.060]	Right	32 1051*	2R
40	8.40	1.30	BeO	13.08	[0.515]	6.35	[0.250]	3.05	[0.120]	1.02	[0.040]	Center	32 1070*	2C
40	8.40	1.30	BeO	6.35	[0.250]	13.08	[0.515]	3.05	[0.120]	1.02	[0.040]	Right	32 1047*	2R
40	8.40	1.30	BeO	6.35	[0.250]	13.08	[0.515]	3.05	[0.120]	1.02	[0.040]	Left	32 1046*	2L
40	6.00	1.30	BeO	5.84	[0.230]	20.32	[0.800]	3.81	[0.150]	1.02	[0.040]	2 Hole	32 1007*	4
50	14.50	1.35	BeO	6.35	[0.250]	13.08	[0.515]	3.81	[0.150]	1.02	[0.040]	Left	32 1200*	2L

Peak power is typically 10 times the max power rating with a 1% duty cycle and 10 microsecond pulse width.

“\*\*” is a place holder. See part number configurations to complete the part number

# 32 & 5 Series

## Product Information



Power	Frequency	VSWR	Substrate	L		W		H		TW		Mounting Direction	Part Series #	Figure #
Watt	GHz	Max:1		mm [inches]										
60	1.50	1.20	BeO	6.48	[0.255]	19.99	[0.787]	3.56	[0.140]	1.52	[0.060]	2 Hole	32 1168*	5
60	2.00	1.35	BeO	13.08	[0.515]	6.35	[0.250]	3.56	[0.140]	1.52	[0.060]	Center	32 1138*	2C
60	6.00	1.20	BeO	6.35	[0.250]	13.08	[0.515]	3.81	[0.150]	1.02	[0.040]	Left	32 1121*	2L
60	6.00	1.20	BeO	6.35	[0.250]	13.08	[0.515]	3.81	[0.150]	1.02	[0.040]	Right	32 1117*	2R
60	6.00	1.20	BeO	6.48	[0.255]	19.99	[0.787]	3.56	[0.140]	1.52	[0.060]	Center	32 1036*	5
60	6.00	1.20	BeO	13.08	[0.515]	6.35	[0.250]	3.81	[0.150]	1.02	[0.040]	Center	32 1122*	2C
60	2.00	1.25	AlN	9.53	[0.375]	22.10	[0.870]	3.48	[0.137]	1.02	[0.040]	2 Hole	32 7196*	7
75	2.40	1.30	BeO	9.52	[0.375]	22.10	[0.870]	5.08	[0.200]	1.52	[0.060]	2 Hole	32 1074*	7
75	1.50	1.40	BeO	9.52	[0.375]	20.83	[0.820]	5.97	[0.235]	6.35	[0.250]	Center	32 1002*	6
100	4.00	1.20	AlN	13.08	[0.515]	6.35	[0.250]	3.56	[0.140]	0.76	[0.030]	Center	32 7165*	2C
100	4.00	1.20	AlN	6.35	[0.250]	13.08	[0.515]	3.56	[0.140]	0.76	[0.030]	Right	32 7164*	2R
100	6.00	1.30	BeO	6.35	[0.250]	13.08	[0.515]	3.56	[0.140]	1.52	[0.060]	Right	32 1158*	2R
100	6.00	1.30	BeO	13.08	[0.515]	6.35	[0.250]	3.56	[0.140]	1.52	[0.060]	Center	32 1157*	2C
100	6.00	1.30	BeO	6.35	[0.250]	13.08	[0.515]	3.56	[0.140]	1.52	[0.060]	Left	32 1156*	2L
100	4.00	1.20	AlN	6.35	[0.250]	13.08	[0.515]	3.81	[0.150]	0.76	[0.030]	Left	32 7163*	2L
100	6.00	1.30	BeO	5.84	[0.230]	20.32	[0.800]	3.81	[0.150]	1.02	[0.040]	2 Hole	32 1055*	4
100	4.00	1.25	BeO	20.32	[0.800]	5.84	[0.230]	4.06	[0.160]	1.02	[0.040]	Right	5653*	4
100	4.00	1.25	AlN	20.32	[0.800]	5.84	[0.230]	4.06	[0.160]	1.02	[0.040]	2 Hole	5653ALN	4
110	2.00	1.25	AlN	1.91	[0.075]	22.10	[0.870]	3.48	[0.137]	1.02	[0.040]	2 Hole	32P7197*	7
120	2.00	1.20	AlN	5.84	[0.230]	20.32	[0.800]	3.81	[0.150]	0.76	[0.030]	Center	32 7187*	4
120	2.00	1.10	AlN	5.84	[0.230]	20.32	[0.800]	3.81	[0.150]	0.76	[0.030]	2 hole	32 7176*	4
120	2.00	1.20	AlN	5.84	[0.230]	20.32	[0.800]	3.81	[0.150]	0.76	[0.030]	2 Hole	32 7025*	4
120	2.00	1.10	BeO	6.35	[0.250]	13.08	[0.515]	3.56	[0.140]	1.52	[0.060]	Right	32 1162*	2R
120	2.00	1.10	BeO	13.08	[0.515]	6.35	[0.250]	3.56	[0.140]	1.52	[0.060]	Center	32 1161*	2C
120	2.00	1.10	BeO	6.35	[0.250]	13.08	[0.515]	3.56	[0.140]	1.52	[0.060]	Left	32 1160*	2L
120	3.00	1.35	AlN	5.84	[0.230]	20.32	[0.800]	4.32	[0.170]	0.76	0.03	2 Hole	32 7027*	4

Peak power is typically 10 times the max power rating with a 1% duty cycle and 10 microsecond pulse width.

“\*\*” is a place holder. See part number configurations to complete the part number





## 32 & 5 Series

### Product Information

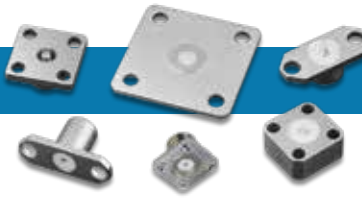
Power	Frequency	VSWR	Substrate	L		W		H		TW		Mounting Direction	Part Series #	Figure #
Watt	GHz	Max:1		mm [inches]										
125	2.00	1.25	AlN	22.22	[0.875]	9.52	[0.375]	4.31	[0.170]	0.76	[0.120]	2 Hole	5307ALN	7
150	2.00	1.15	AlN	9.52	[0.375]	22.10	[0.870]	3.43	[0.135]	0.76	[0.030]	2 Hole	32 7172*	7
150	2.00	1.15	AlN	9.52	[0.375]	22.10	[0.870]	3.43	[0.135]	0.76	[0.030]	2 Hole	32 7023*	7
150	4.00	1.35	BeO	9.52	[0.375]	22.10	[0.870]	3.81	[0.150]	1.02	[0.040]	2 Hole	32 1184*	7
150	4.00	1.35	BeO	9.52	[0.375]	22.10	[0.870]	3.81	[0.150]	1.02	[0.040]	2 Hole	32 1026*	7
150	1.00	1.35	BeO	9.52	[0.375]	22.10	[0.870]	3.81	[0.150]	0.76	[0.120]	2 Hole	32-1003*	7
150	2.50	1.30	AlN	9.53	[0.375]	22.10	[0.870]	3.81	[0.150]	0.76	[0.030]	2 Hole	32 7195*	7
150	2.00	1.25	BeO	22.22	[0.875]	9.52	[0.375]	4.32	[0.170]	0.76	[0.120]	Right	5307*	7
150	2.00	1.25	BeO	22.22	[0.875]	9.52	[0.375]	4.06	[0.160]	0.76	[0.120]	Right	5657*	7
200	1.00	1.20	BeO	5.84	[0.230]	20.32	[0.800]	3.81	[0.150]	1.02	[0.040]	2 Hole	32 1201*	4
200	2.00	1.20	BeO	5.84	[0.230]	20.32	[0.800]	3.81	[0.150]	1.02	[0.040]	2 Hole	32 1196*	4
250	2.70	1.30	AlN	9.52	[0.375]	24.76	[0.975]	5.33	[0.210]	0.76	[0.120]	2 Hole	32 7037*	8
250	2.00	1.15	BeO	9.52	[0.375]	24.76	[0.975]	5.33	[0.210]	1.52	[0.060]	2 Hole	32 1191*	8
250	2.00	1.15	BeO	9.52	[0.375]	24.76	[0.975]	5.33	[0.210]	0.76	[0.120]	Center	32 1037*	8
250	1.00	1.35	BeO	9.52	[0.375]	24.76	[0.975]	5.33	[0.210]	0.76	[0.120]	2 Hole	32 1004*	2L
250	3.00	1.2	BeO	9.53	0.375	22.1	0.87	3.35	0.132	1.02	0.04	2 Hole	32 1213*	7
250	1.00	1.05	AlN	9.52	[0.375]	24.76	[0.975]	5.33	[0.210]	0.76	[0.120]	2 Hole	32 7191*	8
250	2.00	1.25	BeO	24.76	[0.975]	9.52	[0.375]	5.21	[0.205]	0.76	[0.120]	2 Hole	5659*	8
350	2.00	1.55	BeO	12.70	[0.500]	31.75	[1.250]	5.46	[0.215]	1.52	[0.060]	2 Hole	32 1123*	9
400	1.00	1.20	BeO	26.42	[1.040]	48.26	[1.900]	6.35	[0.250]	1.52	[0.060]	4 Hole	32 1017*	10
500	2.00	1.25	BeO	12.70	[0.500]	31.75	[1.250]	0.22	[5.460]	1.52	[0.060]	Center	32 1209*	9
500	1.00	1.00	BeO	12.70	[0.500]	31.75	[1.250]	0.24	[5.970]	1.52	[0.060]	Center	32 1212*	9
800	0.50	1.30	BeO	26.42	[1.040]	48.26	[1.900]	6.22	[0.245]	6.35	[0.250]	4 Hole	32 1199*	10
800	0.50	1.50	BeO	26.42	[1.040]	48.26	[1.900]	6.22	[0.245]	6.35	[0.250]	4 Hole	32 1005*	10
800	0.50	1.10	AlN	26.42	[1.040]	48.26	[1.900]	6.22	[0.245]	6.35	[0.250]	4 Hole	32M7200*	10
1000	0.90	1.20	BeO	25.40	[1.000]	48.26	[1.900]	3.18	[0.125]	3.05	[0.120]	Center	32 5001*	11

Peak power is typically 10 times the max power rating with a 1% duty cycle and 10 microsecond pulse width.

“\*\*” is a place holder. See part number configurations to complete the part number

# Stripline Flange Series

## Flange Termination



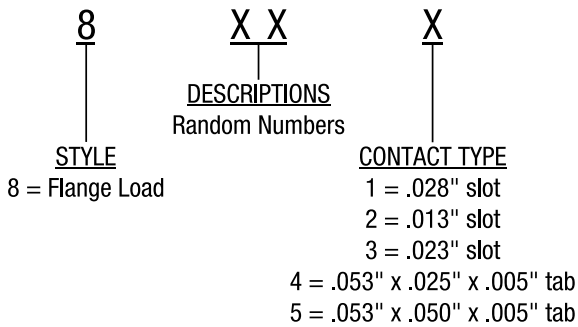
Our Stripline flange terminations are ideal for coaxial isolator applications. Many designs feature a solderless construction. The resistive rod element is staked into the case, forming a highly reliable compression fit. The result is a superior electrical performance which is unaffected by subsequent high temperature manufacturing processes. Many of these products are space-qualified and can be tested for high reliability applications.

Note: Part numbers beginning with "8" offer the solderless construction.

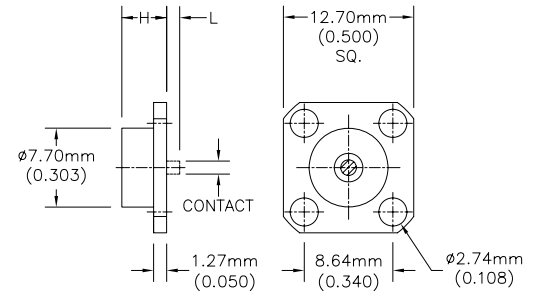
### Specifications

Impedance	50 Ohms +/-5%
Connections	Type N, SMA, SSMA, TNC
Frequency Range	DC to 26.6 GHz
Power Rating	100% @ 100°C
Derates to	0% @ 150 °C
Operating Temperature	-55 °C to 150 °C
Substrates	BeO or Alumina
Resistive Element	Thin Film
Body	Aluminum with Chromate Finish
Tab or Socket Contact	Beryllium Copper, Gold Plated based on MIL-G-45204
Slot Contact	Brass, Gold Plated per SAE AMS 2422

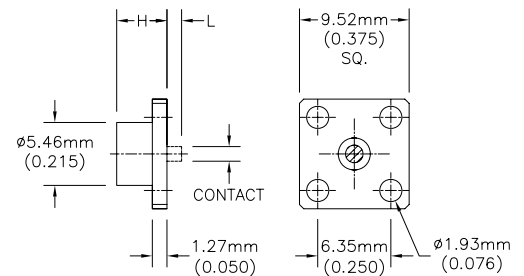
### Part Numbering Code



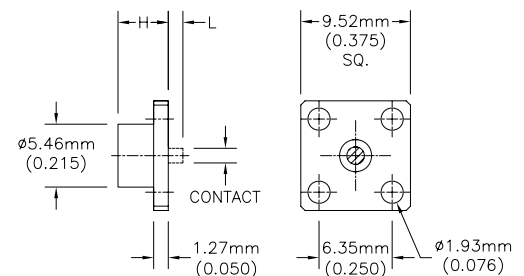
**Figure 1 - 843X Series**



**Figure 2 - 811X Series**



**Figure 3 - 846X Series**



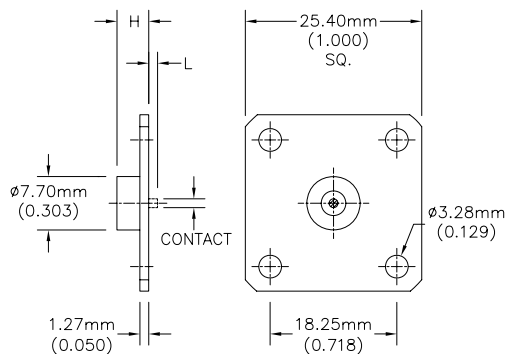
For contact information please refer to Part Numbering Code for Contact Types.



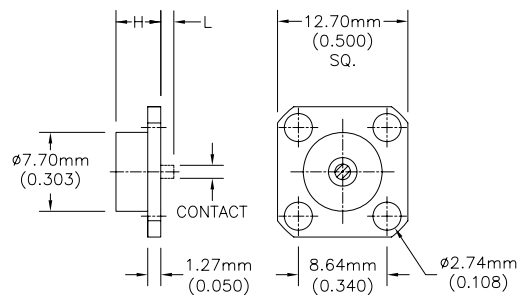
# Stripline Flange Series

## Mechanical Outlines

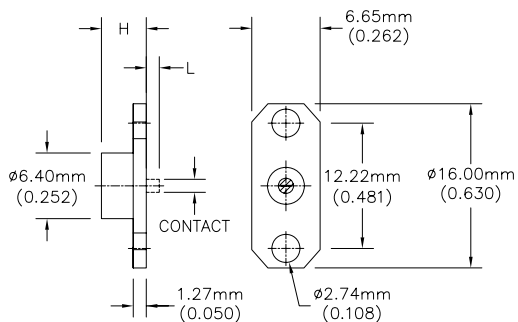
**Figure 4 -  
841X and 842X Series**



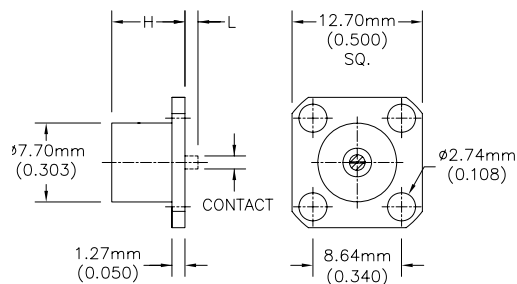
**Figure 5 -  
812X Series**



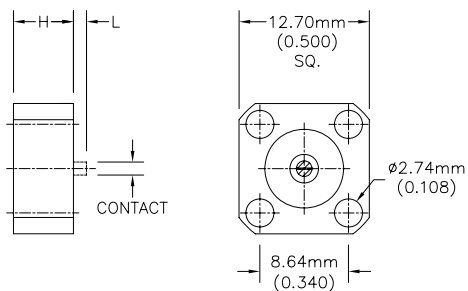
**Figure 6 -  
823X and 827X Series**



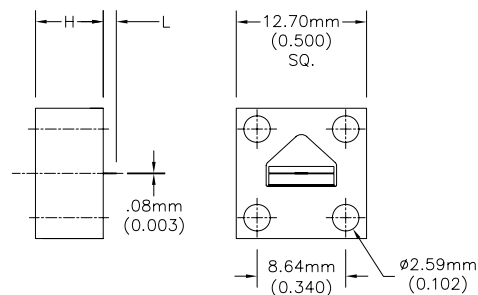
**Figure 7 -  
8482 and 8485 Series**



**Figure 8 -  
8487 and 8488 Series**



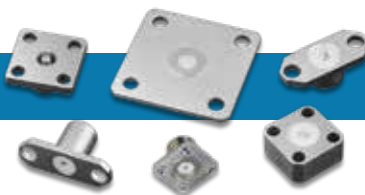
**Figure 9 -  
8750 Series**



For contact information please refer to Part Numbering Code for Contact Types.

# Stripline Flange Series

## Product Information



Power	Freq	VSWR	Substrate	Component Diameter		Contact Height Max		Contact Thickness		Hole Diameter		Mounting	Part Series #	Figure #
Watt	GHz	Max:1		mm [inches]										
1	26.5	1.20	BeO	9.52	[0.375]	4.37	[0.172]	1.35	[0.053]	1.93	[0.076]	4-hole	811*	Fig 2
1	26.5	1.20	BeO	12.7	[0.500]	4.37	[0.172]	1.35	[0.053]	2.74	[0.108]	4-hole	812*	Fig 5
1	18.0	1.30	Alumina	16.00 L x 5.72 W	[0.63 L x 0.225 W]	4.37	[0.172]	1.35	[0.053]	2.74	[0.108]	2-hole	823*	Fig 6
1	12.0	1.20	Alumina	25.4	[1.000]	4.57	[0.180]	1.35	[0.053]	3.28	[0.129]	4-hole	841*	Fig 4
1	18.0	1.30	Alumina	12.7	[0.500]	4.37	[0.172]	1.35	[0.053]	2.74	[0.108]	4-hole	843*	Fig 1
1	18.0	1.30	Alumina	9.52	[0.375]	4.37	[0.172]	1.35	[0.053]	1.93	[0.076]	4-hole	846*	Fig 3
10	18.0	1.40	BeO	16.00 L x 6.65 W	[0.63 L x 0.262 W]	4.37	[0.172]	1.35	[0.053]	2.74	[0.108]	2-hole	827*	Fig 6
10	12.0	1.25	BeO	25.4	[1.000]	4.57	[0.180]	1.35	[0.053]	3.28	[0.129]	4-hole	842*	Fig 4
25	14.5	1.50	BeO	12.7	[0.500]	7.14	[0.281]	1.35	[0.053]	2.74	[0.108]	4-hole	8482	Fig 7
25	14.5	1.50	BeO	12.7	[0.500]	7.14	[0.281]	1.35	[0.053]	2.74	[0.108]	4-hole	8485	Fig 7
25	14.5	1.50	BeO	12.7	[0.500]	7.14	[0.230]	1.35	[0.053]	2.74	[0.108]	4-hole	8487	Fig 8
25	14.5	1.50	BeO	12.7	[0.500]	7.14	[0.230]	1.35	[0.053]	2.74	[0.108]	4-hole	8488	Fig 8
75	5.0	1.50	BeO	12.7	[0.500]	6.35	[0.260]	0.08	[0.003]	2.59	[0.102]	4-hole	875*	Fig 9

Peak power is typically 10 times the max power rating with a 1% duty cycle and 10 microsecond pulse width.

Please call for your specific application.

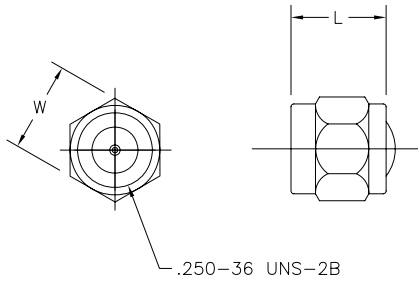
“\*\*\*” except where L and W are noted

“\*\*” is a place holder. See part number configurations to complete the part number

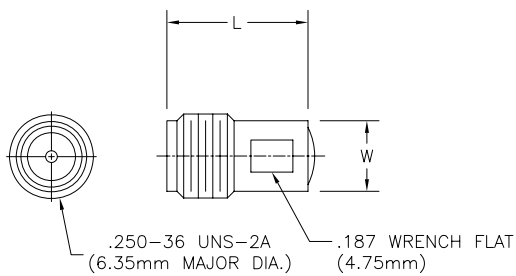
- X = 1 .028 Slot
- 2 .013 Slot
- 3 .023 Slot
- 4 .025 Wide Tab
- 5 .050 Wide Tab



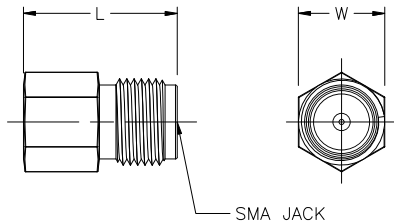
**Figure 1 - SMA Plug/Male**



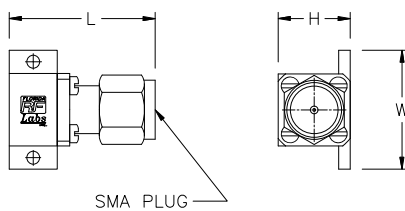
**Figure 2 - SMA Jack/Female**



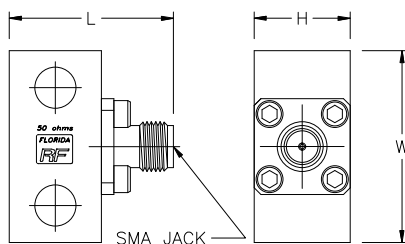
**Figure 3 - SMA Jack/Female**



**Figure 4 - High Power SMA**



**Figure 4a**



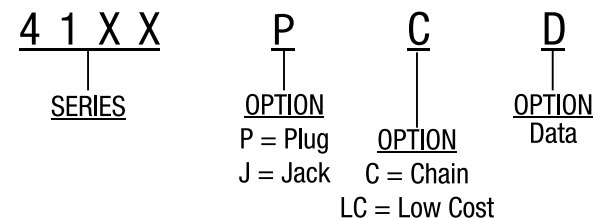
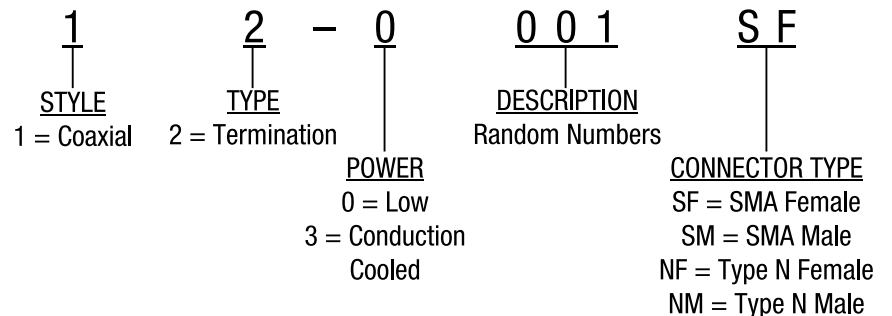
**Figure 4b**

Attenuators aren't the only products where we have combined EMC Technology components with Florida RF Labs connector expertise! We also offer a complete series of SMA, 3.5 mm and 2.9 mm interface compatible coaxial terminations. Some designs are specifically suited for narrow or wide band applications. These terminations have low VSWR, and operate at frequencies from DC to 26.5 GHz. They are ideal for both laboratory measurements and system use.

### Specifications

Impedance	50 Ohms
Connector	SMA, 3.5mm, 2.9mm
Frequency Range	DC to 26.5 GHz
Power	0.5 to 3 Watts
Power Rating	100% @ 100°C
Derates to	0% @ 150 °C
Operating Temperature	-55 °C to 150 °C
Resistor	Thin Film
Substrate	BeO or Alumina
Body & Coupling Nut Material	Stainless Steel
Body & Coupling Nut Finish	Passivated
Contact	Beryllium Copper
Contact Finish	Gold

### Part Numbering Code



# 12 & 41 Series

## Product Information



### Low Power

Part Series #	Power (Watts)	Substrate	Max Freq (GHz)	VSWR Max:1	L		W		Figure #
					mm [inches]				
12-0001*	1.0	Alumina	18.0	1.15	8.89	[0.350]	7.92	[0.312]	1
12-0002*	1.0	Alumina	26.5	1.10	8.89	[0.350]	7.92	[0.312]	1
12-0006*	0.5	Alumina	12.4	1.17	13.33	[0.525]	7.92	[0.312]	1
12-0007*	0.5	Alumina	6.0	1.10	8.89	[0.350]	7.92	[0.312]	1
12-0008*	1.0	Alumina	18.0	1.30	8.89	[0.350]	7.92	[0.312]	1
12-0009*	3.0	BeO	18.0	1.20	13.33	[0.525]	7.92	[0.312]	1
12-0028*	1.0	Alumina	2.0	1.10	8.89	[0.350]	7.92	[0.312]	1
12-0101*	1.0	Alumina	18.0	1.15	13.33	[0.525]	7.92	[0.312]	2
12-0102*	1.0	Alumina	26.5	1.10	13.33	[0.525]	7.92	[0.312]	2
4110J	2.0	Alumina	18.0	1.20	11.30	[0.445]	6.35	[0.250]	3
4111P	2.0	Alumina	18.0	1.15	12.70	[0.500]	7.92	[0.312]	1
4111PCD	2.0	Alumina	18.0	1.10	12.70	[0.500]	7.92	[0.312]	1
4112P	1.0	Alumina	18.0	1.25	8.38	[0.330]	7.92	[0.312]	1
4112PLC	1.0	Alumina	2.5	1.05	8.38	[0.330]	7.92	[0.312]	1
4113P	1.0	Alumina	18.0	1.15	8.38	[0.330]	7.92	[0.312]	1
4113PCD	1.0	Alumina	18.0	1.10	8.38	[0.330]	7.92	[0.312]	1

Peak power is typically 10 times the max power rating with a 1% duty cycle and 10 microsecond pulse width.

Please call for your specific application

“\*\*” is a place holder. See part number configurations to complete the part number.

### Conduction Cooled

Part Series #	Power (Watts)	Substrate	Max Freq (GHz)	VSWR Max:1	L		W		H		Figure #
					mm [inches]						
12-3001*	15.0	BeO	18.0	1.20	6.35	[0.250]	15.75	[0.620]	9.53	[0.375]	4
12-3002*	15.0	BeO	18.0	1.30	12.19	[0.480]	25.40	[1.000]	12.70	[0.500]	4
12-3005*	50.0	BeO	6.0	1.35	34.93	[1.375]	24.38	[0.960]	14.22	[0.560]	4
12-3007*	100.0	BeO	3.0	1.25	34.93	[1.375]	24.38	[0.960]	14.22	[0.560]	4
12-3022*	25.0	BeO	18.0	1.25	17.27	[0.680]	22.23	[0.875]	12.70	[0.500]	4

Peak power is typically 10 times the max power rating with a 1% duty cycle and 10 microsecond pulse width.

Please call for your specific application

“\*\*” is a place holder. See part number configurations to complete the part number.

### Features

- Lead Free, RoHS Compliant Option Available
- Low Capacitance
- Mounting - Surface Mount, Tab & Cover, Flange, and Rod
- Power Levels: 0.05 to 800 Watts
- 50 and 100 Ohms Standard
- Tight Resistance Tolerance -  $\pm 5\%$ ,  $\pm 2\%$ , and  $\pm 1\%$  Available
- Tuned Circuit
- Available in AlN, BeO, or Alumina
- Substrate Thicknesses of .015" to .120" Available
- Rod Diameters of .020" to .375"
- Custom Tab Forming Available
- Resistance Ranges from 3 to 400 Ohms
- Small Footprint and Low profile

### Applications

- Base Stations
- Broadcast (TV and Radio)
- High Power Amplifier
- Instrumentation
- Military
- Radar System
- Satellite Communications
- Splitters/Combiners
- Voltage Dropping Resistor
- Wilkinson Dividers

For our **CVD Diamond Resistors** see **Diamond Rf Resistives®** on pages 65 to 74



EMC Technology offers low and high power RF resistors including surface mount chips, tab & cover chips, flange mounted and rod types. These resistors are available with Alumina, AlN, BeO and CVD substrate materials. Some devices use a tuned circuit design to minimize parasitic capacitance across their usable frequency bands. Most devices are available in a wide range of resistance values, typically from 1 ohm to 1,000 ohms.

Choose from a variety of metallization finishes for easy mounting to a heat sink or directly to a printed circuit board. Typical finishes include: Lead-free, RoHS compliant plating (silver or gold), solder finish with Sn60Pb40 or solder fused finish with Sn60Pb40 depending upon package type. Select from bulk, tape & reel, or waffle packaging, again, depending upon resistor package style.

### Quick Selector Chart

Mounting Style	Power (Watts)	Page
Surface Mount Chip	800	56-57
Tab & Cover	500	58-59
Flange	800	60-62
Rod	40	63

# Surface Mount

## Chip Resistor

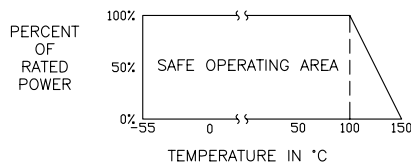


Surface mount chip resistors are available in three different terminal styles for either RF or DC applications, such as bias voltage dropping or heaters. Terminal Style A has a full backside metallization for direct attachment to a heat sink or an item to be heated. Terminal Style B has wrap-around divider for low power SMT applications. Terminal Style C has a split ground that allows it be mounted as a resistor or termination. This style provides a larger ground area for increased heat dissipation and is an excellent choice for high power SMT applications.

### Specifications

Standard Resistance	50 & 100 Ohms $\pm 5\%$
Resistance Range	3 to 400 Ohms
Power	2 to 800 Watts
Power Rating	100% @ 100°C
Derates to	0% @ 150°C
Operating Temperature	-55°C to 150°C
Substrate	BeO, AlN or Alumina
Resistive Element	Thin or Thick Film
Solderable Terminals	See Plating Option
Environment	Meets applicable sections of MIL-PRF-55342

### Power Rating and Derating

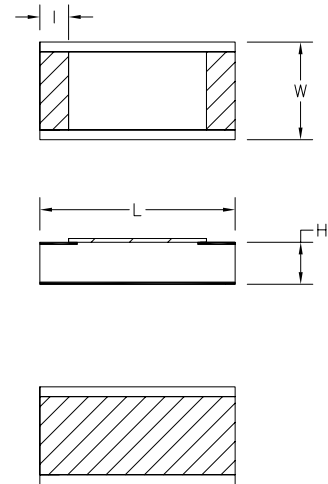


### Part Numbering Code

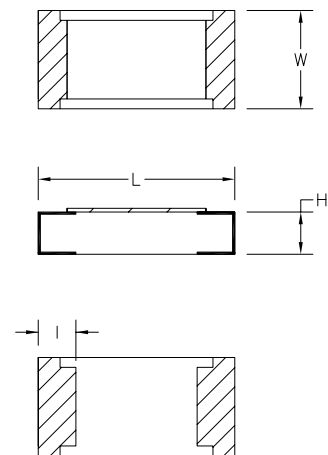
8	1	A	7	0 4 2	—	1 0 0	—	5	F
<b>STYLE</b>	<b>PLATING OPTION</b>	<b>DESCRIPTIONS</b>	<b>RESISTANCE</b>	<b>TOLERANCE</b>					
8 = Chip / Power Pak	— = Tin Lead <sup>†1</sup> A = Silver Nickel B = Silver Copper M = Non-magnetic	Random Numbers	Value in ohms	1 = 1% 2 = 2% 5 = 5% 10 = 10%					
<b>TYPE</b>	<b>SUBSTRATE MATERIAL</b>	<b>ENVIRONMENTAL COMPLIANCE</b>							
1 = Resistor	7 = Aluminum Nitride 8 = Alumina 3 = Beryllium Oxide	(blank) = RoHS Compliant F = RoHS Compliant							
	(blank) = Style C A = Style A B = Style B								

<sup>†1</sup> Not RoHS Compliant

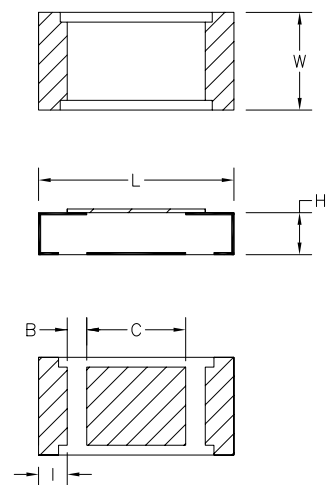
#### Style A



#### Style B



#### Style C







Power	Resistance	Substrate	Capacitance	L		W		H		Part Series #
Watt	Range			mm [inches]						
2	10-250	Alumina	0.10	3.05	[0.120]	1.52	[0.060]	0.38	[0.015]	81 8004B*
5	25-200	Alumina	0.10	5.08	[0.200]	2.54	[0.100]	1.02	[0.040]	81 8002B*
5	25-200	AlN	0.27	5.08	[0.200]	2.54	[0.100]	1.02	[0.040]	81 7001B*
5	2.5-200	BeO	0.80	5.08	[0.200]	2.54	[0.100]	1.02	[0.040]	81 3001B*
6	5-150	BeO	/1	5.08	[0.200]	5.08	[0.200]	1.02	[0.040]	81 3002Bv
8	3-200	BeO	0.66	6.35	[0.250]	6.35	[0.250]	1.57	[0.062]	81 3012B*
8	5-75	BeO	0.85	5.84	[0.230]	8.89	[0.350]	1.02	[0.040]	81 3005B*
8	3-200	BeO	1.00	6.35	[0.250]	6.35	[0.250]	1.02	[0.040]	81 3003B*
10	10-300	AlN	/1	5.08	[0.200]	2.54	[0.100]	1.02	[0.040]	81 7031*
10	15-400	BeO	0.10	5.08	[0.200]	2.54	[0.100]	1.02	[0.040]	81 3031*
10	7-250	BeO	1.33	9.53	[0.375]	6.35	[0.250]	1.02	[0.040]	81 3006B*
10	5-200	BeO	0.80	5.08	[0.200]	2.54	[0.100]	1.02	[0.040]	81 3001A*
10	10-300	AlN	0.10	5.08	[0.200]	2.54	[0.100]	1.02	[0.040]	81 7031
12	5-250	BeO	1.64	9.53	[0.375]	9.53	[0.375]	1.02	[0.040]	81 3008B*
15	5-150	BeO	/1	5.08	[0.200]	5.08	[0.200]	1.02	[0.040]	81 3002A*
20	15-300	AlN	1.50	9.53	[0.375]	6.35	[0.250]	1.02	[0.040]	81 7042
20	5-75	BeO	6.00	6.35	[0.250]	6.35	[0.250]	1.02	[0.040]	81 3039*
20	7-250	BeO	1.50	9.53	[0.375]	6.35	[0.250]	1.02	[0.040]	81 3032*
30	5-120	BeO	0.85	5.84	[0.230]	8.89	[0.350]	1.02	[0.040]	81 3005A*
50	5-200	AlN	/1	9.53	[0.375]	9.53	[0.375]	1.02	[0.040]	81 7028*
50	10-400	BeO	1.35	17.78	[0.700]	8.89	[0.350]	1.52	[0.060]	81 3036*
50	5-120	BeO	1.00	6.35	[0.250]	6.35	[0.250]	1.02	[0.040]	81 3003A*
100	12-400	BeO	4.48	25.40	[1.000]	25.40	[1.000]	1.52	[0.060]	81 3011B*
150	7-250	BeO	1.33	9.53	[0.375]	6.35	[0.250]	1.02	[0.040]	81 3006A*
250	5-200	BeO	/1	9.53	[0.375]	9.53	[0.375]	1.02	[0.040]	81 3028*
800	12-400	BeO	4.48	25.40	[1.000]	25.40	[1.000]	1.52	[0.060]	81 3011A*

Peak power is typically 10 times the max power rating with a 1% duty cycle and 10 microsecond pulse width.

/1 Varies by resistance value within the range. Call the Sales department for more information.

“\*” is a place holder. See part number configurations to complete the part number.

For L, B and C dimensions see data sheet on website.

# Tab & Cover

## Resistor

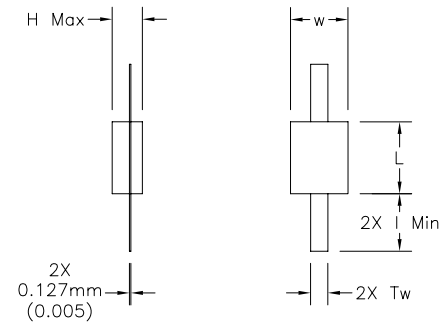


Tab & Cover resistors are ideal for mounting directly to a heat sink or onto a circuit board. The resistors are available with BeO, Aluminum Nitride (AlN) or Alumina substrates. These devices have standard resistance values of 50 & 100 ohms, however, are available in many non-standard values as well. The power rating ranges from 10 to 500 watts. Applications include Wilkinson divider/combiner that require low capacitance to ground. Packaging options are tray or tape & reel. All devices are available RoHS compliant.

### Specifications

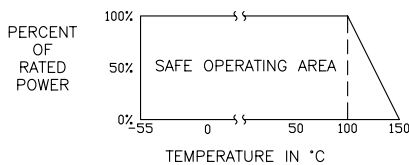
Standard Resistance	50 & 100 Ohms ±5%
Resistance Range	5 to 400 Ohms
Power	10 to 500 Watts
Power Rating	100% @ 100°C
Derates to	0% @ 150°C
Operating Temperature	-55°C to 150°C
Substrate	BeO, AlN or Alumina
Resistor	Thin Film
Tab Contact	Beryllium copper
Cover	Alumina
Ground Plane	Plated Thick Film

### 81-Series Tab & Cover

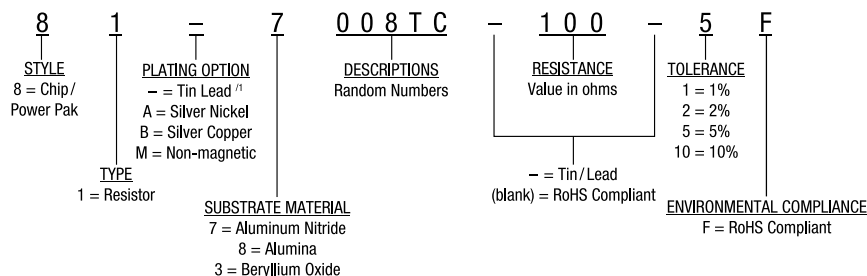


For "1 min" and Tw dimensions see data sheet on website.

### Power Rating and Derating



### Part Numbering Code



<sup>1)</sup> Not RoHS Compliant



Power	Resistance	Substrate	Capacitance	L		W		H		Part Series #
Watt	Range			mm [inches]						
10	10-250	AlN	0.57	5.08	[0.200]	2.54	[0.100]	2.16	[0.085]	81 7008TC /1
10	10-250	AlN	/5	5.08	[0.200]	2.54	[0.100]	2.16	[0.085]	81 7006TC /2
10	5-200	BeO	0.80	5.08	[0.200]	2.54	[0.100]	2.29	[0.090]	81 3001TC*
15	5-150	BeO	1.00	5.08	[0.200]	5.08	[0.200]	2.16	[0.085]	81 3002TC*
20	3-250	BeO	1.00	6.35	[0.250]	6.35	[0.250]	2.67	[0.105]	81 3012TC*
30	10-400	BeO	0.50	6.35	[0.250]	6.35	[0.250]	2.16	[0.085]	81 3034TC*
40	10-250	AlN	0.52	6.35	[0.250]	6.35	[0.250]	2.16	[0.085]	81 7108TC /3
40	10-250	AlN	0.25	5.84	[0.250]	8.89	{0.350}	2.16	[0.085]	81 7107TC /4
40	9-300	BeO	0.50	6.35	[0.250]	8.89	{0.350}	2.16	[0.085]	81 3035TC*
50	5-200	AlN	0.45	6.35	[0.250]	9.53	[0.375]	2.16	[0.085]	81 7109TC*
50	5-120	BeO	1.00	6.35	[0.250]	6.35	[0.250]	2.16	[0.085]	81 3003TC*
60	5-200	BeO	0.70	6.35	[0.250]	9.53	[0.375]	1.02	[0.040]	81 3033TC*
100	14-250	AlN	1.50	9.53	[0.375]	6.35	[0.250]	2.16	[0.085]	81 7043TC
150	7-250	AlN	1.38	9.53	[0.375]	6.35	[0.250]	2.16	[0.085]	81 7021TC*
150	12-400	BeO	0.50	9.53	[0.375]	6.35	[0.250]	2.67	[0.105]	81 3075TC*
150	7-250	BeO	1.33	9.53	[0.375]	6.35	[0.250]	2.16	[0.085]	81 3006TC*
200	10-250	AlN	1.40	9.53	[0.375]	9.53	[0.375]	2.16	[0.085]	81 7110TC*
250	10-350	BeO	1.00	9.53	[0.375]	9.53	[0.375]	2.67	[0.105]	81 3076TC*
250	5-250	BeO	1.64	9.53	[0.375]	9.53	[0.375]	2.16	[0.085]	81 3008TC*
400	5-200	BeO	3.25	12.70	[0.500]	12.70	[0.500]	2.16	[0.085]	81 3074TC*
500	10-400	BeO	1.50	12.70	[0.500]	12.70	[0.500]	2.16	[0.085]	81 3123TC*
500	10-400	BeO	1.50	12.70	[0.500]	12.70	[0.500]	1.02	[0.040]	81 3027TC*

/1 & /2 Slightly different specifications

/3 & /4 Slightly different body size and lead length

Peak power is typically 10 times the max power rating with a 1% duty cycle and 10 microsecond pulse width.

Capacitance is parallel and measured to 2.7 GHz.

“\*\*” is a place holder. See part number configuration to complete the part number.

For a complete part number, include resistance and tolerance as described above in ordering information.

Please call the Sales department for specific applications.

# Flange

## Resistor

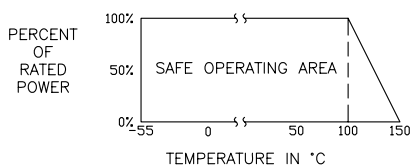


Flange resistors are excellent for mounting directly to heat sinks for improved heat dissipation. The devices are available in single, double and four hole flange mounting styles. These devices have standard resistance values of 50 & 100 ohms, however most designs are available in non-standard values as well. The flange resistors are offered in power ratings ranging from 10 to 1000 watts. Many designs are available in both BeO and Aluminum Nitride (AlN) substrates. The 31-XXXX designs, traditionally have a thin film resistor while the 5XXX designs, use a thick film resistor.

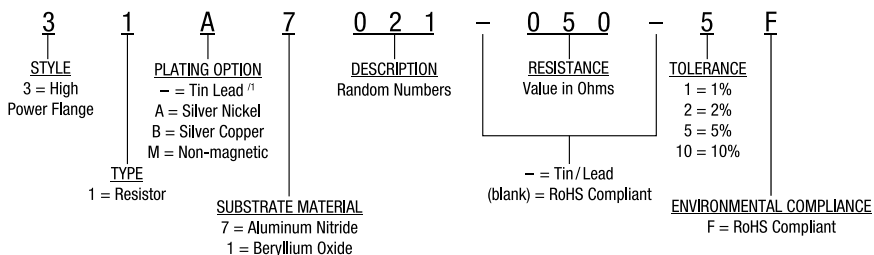
### Specifications

Standard Resistance	50 & 100 Ohms ±5%
Resistance Range	4 to 400 Ohms
Power	10 to 800 Watts
Power Rating	100% @ 100°C
Derates to	0% @ 150°C
Operating Temperature	-55°C to 150°C
Substrate	BeO or AlN
Resistor	Thin or Thick Film
Tab Contact	Beryllium Copper
Cover	Alumina
Mounting Flange	Copper, Nickel Plated

### Power Rating and Derating



### Part Numbering Code



<sup>1</sup> Not RoHS Compliant

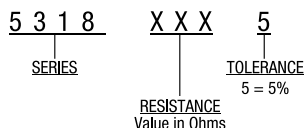


Figure 1

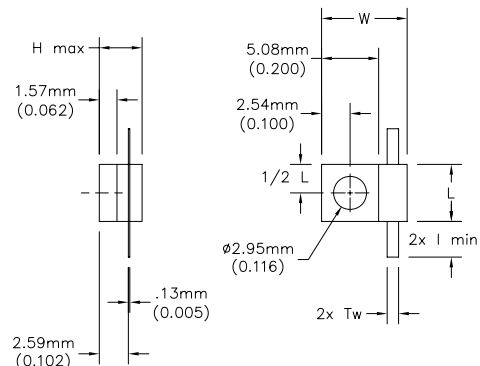


Figure 2

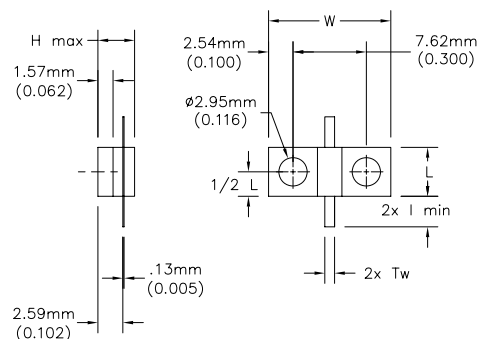
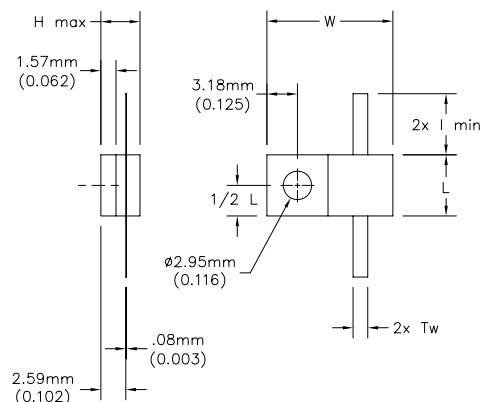
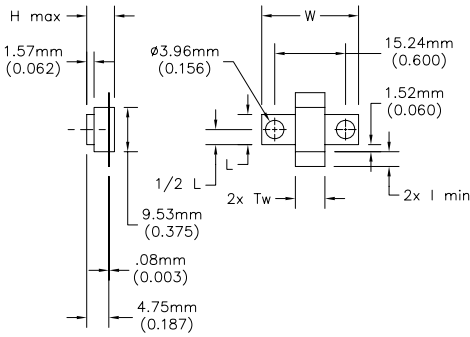


Figure 3

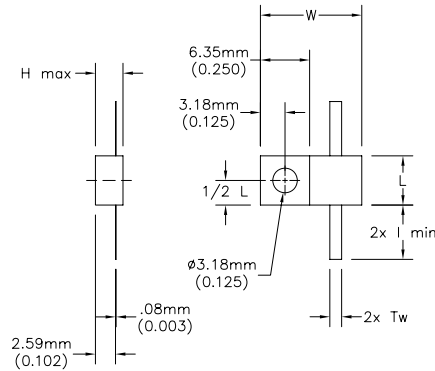




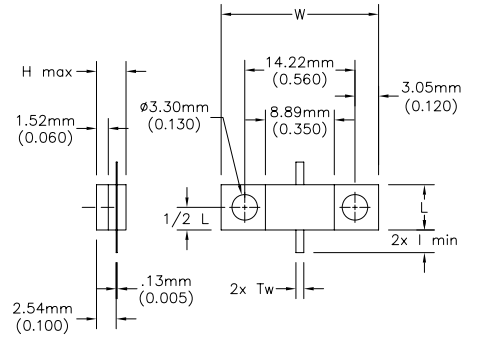
**Figure 4**



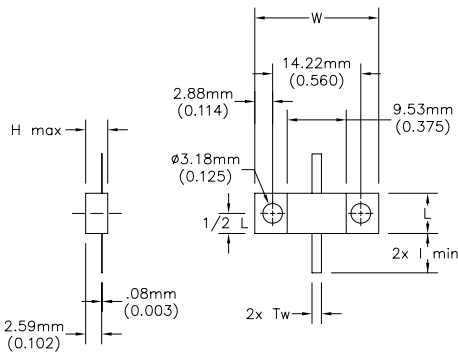
**Figure 5**



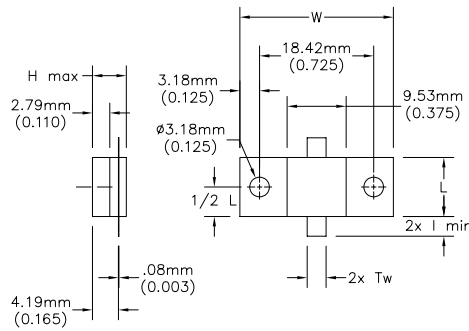
**Figure 6**



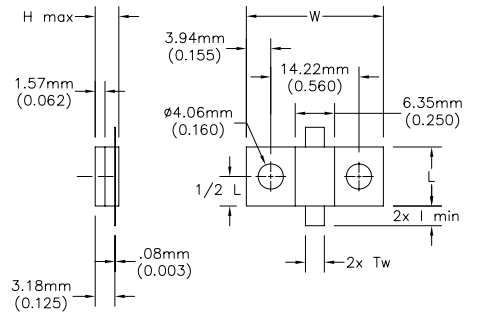
**Figure 7**



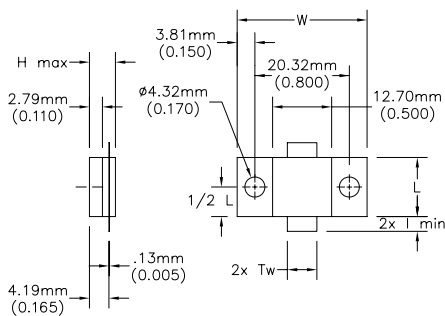
**Figure 8**



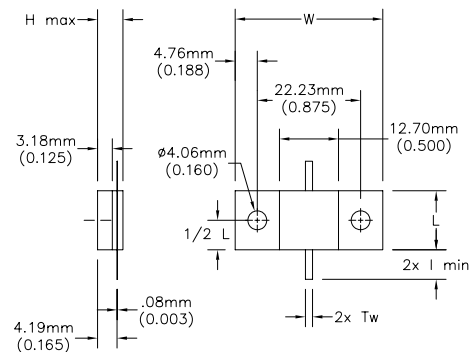
**Figure 9**



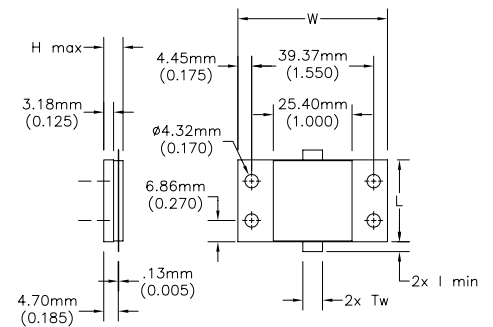
**Figure 10**



**Figure 11**



**Figure 12**



# Flange

## Product Information



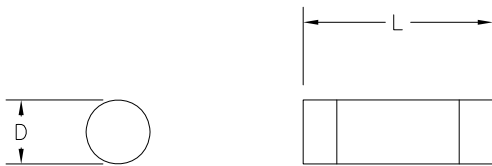
Power Watt	Resistance Range	Substrate	Capacitance	L		W		H		Part Series #	Figure #
				mm [inches]							
10	5-200	BeO	0.80	5.08	[0.200]	12.70	[0.500]	3.81	[0.150]	31 1008*	2
10	5-200	BeO	0.80	5.08	[0.200]	7.62	[0.300]	3.81	[0.150]	31 1006*	1
10	25-250	BeO	1.30	7.62	[0.300]	5.08	[0.200]	4.06	[0.160]	5318 XXX,5	1
20	10-250	AlN	0.80	5.08	[0.200]	12.70	[0.500]	3.81	[0.150]	31 7008*	1
20	10-250	AlN	0.57	5.08	[0.200]	7.62	[0.300]	3.81	[0.150]	31 7006*	1
20	10-400	BeO	0.20	6.35	[0.250]	13.08	[0.515]	4.32	[0.170]	31 1094*	3
20	10-150	BeO	1.00	6.35	[0.250]	20.83	[0.820]	5.97	[0.235]	31 1010*	7
20	3-250	BeO	0.60	6.35	[0.250]	13.08	[0.515]	4.06	[0.160]	31 1009*	3
20	3-250	BeO	0.60	6.35	[0.250]	13.08	[0.515]	4.06	[0.160]	31 1001*	3
25	25-250	BeO	2.50	12.70	[0.500]	6.48	[0.255]	4.32	[0.170]	5310 XXX,5	2
25	25-250	BeO	2.00	13.08	[0.515]	6.35	[0.250]	4.06	[0.160]	5326 XXX,5	2
30	10-400	BeO	0.50	6.35	[0.250]	13.08	[0.515]	3.56	[0.140]	31 1034*	5
40	5-300	AlN	0.80	6.35	[0.250]	13.08	[0.515]	3.81	[0.150]	31 7108*	3
40	10-250	AlN	0.25	5.84	[0.250]	20.32	[0.800]	3.81	[0.150]	31 7107*	6
40	10-400	BeO	0.50	6.35	[0.250]	13.08	[0.515]	3.56	[0.140]	31 1089*	3
40	9-300	BeO	0.50	5.84	[0.230]	20.32	[0.800]	3.81	[0.150]	31 1035*	6
40	9-300	BeO	0.50	5.84	[0.230]	20.32	[0.800]	3.81	[0.150]	31 1007*	6
40	25-250	BeO	3.40	20.32	[0.800]	5.84	[0.230]	4.06	[0.160]	5654 XXX,5	6
50	5-300	AlN	0.45	6.48	[0.255]	19.99	[0.787]	3.56	[0.140]	31 7109*	7
60	5-200	BeO	0.70	6.48	[0.255]	19.99	[0.787]	3.56	[0.140]	31 1033*	7
75	7-250	BeO	0.50	9.53	[0.375]	20.83	[0.820]	5.97	[0.235]	31 1002*	4
150	7-1000	BeO	0.8	9.52	[0.375]	14.30	[0.563]	4.32	[0.170]	31 1125*	5
150	7-250	AlN	2.25	9.53	[0.375]	22.10	[0.870]	4.32	[0.170]	31 7021*	9
150	12-400	BeO	0.50	9.53	[0.375]	22.10	[0.870]	4.32	[0.170]	31 1075*	9
150	7-1000	BeO	0.80	9.53	[0.375]	22.10	[0.870]	4.32	[0.170]	31 1021	9
150	7-250	BeO	1.33	9.53	[0.375]	22.10	[0.870]	3.81	[0.150]	31 1003*	9
150	5-600	BeO	/1	5.84	[0.230]	20.32	[0.800]	3.81	[0.150]	31 1086*	9
150	25-250	BeO	3.80	22.23	[0.875]	9.53	[0.375]	4.32	[0.170]	5308 XXX,5	9
200	10-350	AlN	1.40	9.53	[0.375]	24.77	[0.975]	5.46	[0.215]	31 7110*	8
250	10-350	BeO	1.00	9.53	[0.375]	24.77	[0.975]	5.46	[0.215]	31 1098*	8 /2
250	10-350	BeO	1.00	9.53	[0.375]	24.77	[0.975]	5.46	[0.215]	31 1076*	8
250	5-150	BeO	2.00	24.77	[0.975]	9.53	[0.375]	7.11	[0.280]	31 1059	8
250	5-250	BeO	1.64	9.53	[0.375]	24.77	[0.975]	5.46	[0.215]	31 1004*	8
250	25-250	BeO	4.30	24.77	[0.975]	9.53	[0.375]	5.21	[0.205]	5660 XXX,5	8
400	5-200	BeO	3.25	12.70	[0.500]	27.94	[1.100]	5.59	[0.220]	31 1074*	10
500	10-400	BeO	1.50	12.70	[0.500]	31.75	[1.250]	5.46	[0.215]	31 1123*	11
750	10-400	BeO	4.50	26.42	[1.040]	48.26	[1.900]	6.35	[0.250]	31 1054*	12
800	12-400	BeO	4.48	26.42	[1.040]	48.26	[1.900]	6.22	[0.245]	31 1005*	12
800	7-175	BeO	1.00	26.42	[1.040]	48.26	[1.900]	6.22	[0.245]	31 1099*	12

/1 Varies by resistance value within the range. Call the Sales department for more information.

/2 Formed Tabs



**Rod**

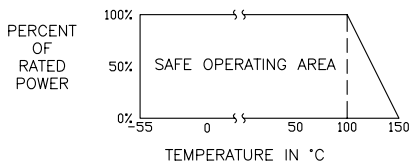


Rod resistors are typically used in wideband high performance coaxial terminations. They feature thin film resistance elements trimmed without kerfs for stable, high frequency characteristics. The high temperature protective coating protects the film during assembly operations. In applications where one end of the rod resistor is soldered directly to the heat sink, power handling as much as 10 times its rated power may be achieved.

Terminations constructed with our rod resistors, when designed properly, will yield a maximum VSWR of 1.05:1 at 4 GHz and 1.1:1 at 12 GHz.

Standard resistance range: 10-250 ohms with tolerance of 5%.

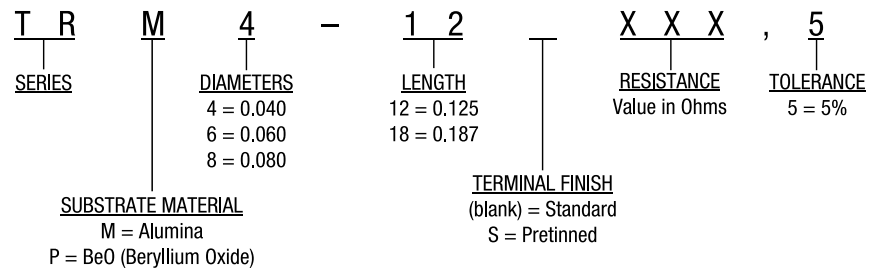
**Power Rating and Derating**



**Specifications**

Standard Resistance	50 & 100 Ohms
Resistance Range	3 to 400 Ohms
Power	0.05 to 20 Watts
Power Rating	100% @ 100°C
Derates to	0% @ 150°C
Operating Temperature	-55°C to 150°C
Substrate	BeO or Alumina
Resistive Element	Thin Film
Solderable Terminals	See Plating Option

**Part Numbering Code**



Power Watt	Substrate	L		D		Part Series #
		mm [inches]				
1	Alumina	3.18	[0.125]	1.02	[0.040]	TRM 4-12
2	Alumina	3.18	[0.125]	1.52	[0.060]	TRM 6-12
2	Alumina	4.75	[0.187]	1.52	[0.060]	TRM 6-18
2	BeO	3.18	[0.125]	1.02	[0.040]	TRP 4-12
4	Alumina	4.75	[0.187]	2.03	[0.080]	TRM 8-18
10	BeO	3.18	[0.125]	1.52	[0.060]	TRP 6-12
10	BeO	4.75	[0.187]	1.52	[0.060]	TRP 6-18
20	BeO	4.75	[0.187]	2.03	[0.080]	TRP 8-18

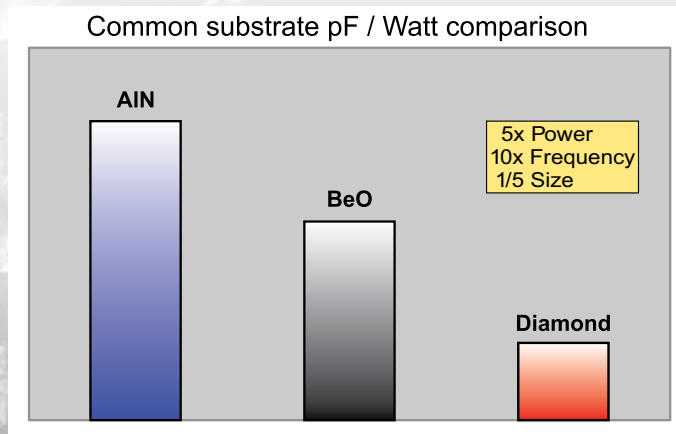
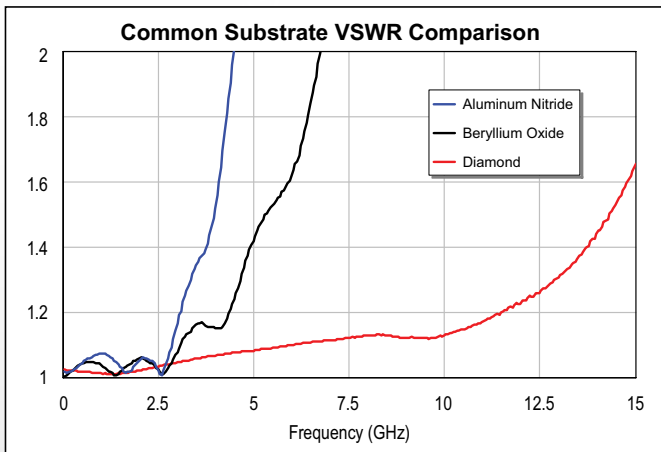
# ***Resistors***

Notes



Diamond is the best thermal conductor on earth. Combined with a low dielectric constant, it is an excellent RF dielectric material for high-frequency applications in which thermal performance is equally critical.

By applying cutting-edge thin film process and extensive millimeter wave design experience, EMC Technology has created a high-performance line of resistive components. The resulting products, our Diamond Rf® resistors, terminations, and attenuators, are significantly reduced in size and unparalleled in average and peak power handling.



### Quick Selector Chart

Series	Page
Diamond Attenuators	66-68
Diamond Resistors	69-71
Diamond Terminations	72-74

# Diamond Rf Resistives®



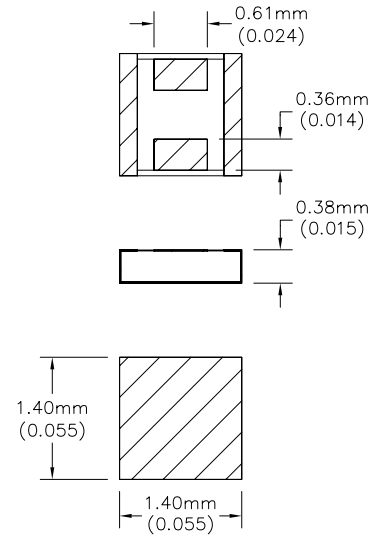
## Diamond Chip Attenuator

EMC Technology offers a line of CVD Diamond chip attenuators with extremely high power ratings. With operating frequency of DC to 26.5 GHz, these products are ideal for military and space applications because of their high power handling capability, broad frequency response and small footprint. The CA0505D are manufactured using all thin film construction. The gold finish on terminals is both wire-bondable and solderable. Standard chip and high reliability tested versions per Mil-PRF-55342 are available. Select from tape and reel or waffle packaging. These products are lead free, RoHS compliant and S-level approved. Standard available values are 1 through 10, 20, and 30 dB.

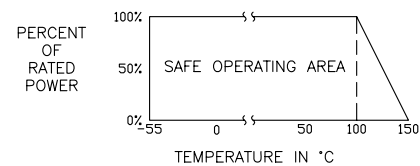
### Specifications

Nominal Impedance	50 Ohms
Frequency Range	DC to 26.5 GHz
Attenuation Values	1 thru 10, 20 and 30 dB
Power Rating	20 Watts
Operating Temperature	-55 °C to 150 °C
Resistive Material	Thin Film
Terminal Material	Thin Film, Gold Solderable or Bondable Finish

### CA0505D



### Power Rating and Derating



#### Attenuation Accuracy (dB)

dB VALUE	DC - 8 GHz	8 -12.4 GHz	12.4 - 18 GHz	18 - 26.5 GHz
0	+ 0.25	+ 0.30	+ 0.50	+ 0.70
1 - 3	± 0.25	± 0.30	± 0.50	± 0.50
4 - 6	± 0.25	± 0.30	± 0.50	± 0.75
7 - 10	± 0.25	± 0.30	± 0.50	± 1.00
20	± 0.50	± 0.50	± 0.75	± 1.00
30	± 0.50	± 0.50	± 1.00	± 1.50

#### VSWR (Max)

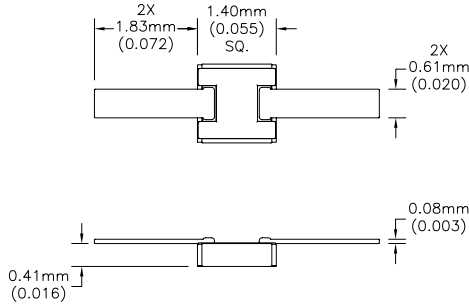
dB VALUE	DC - 8 GHz	8 -12.4 GHz	12.4 - 18 GHz	18 - 26.5 GHz
0	1.25	1.30	1.40	1.50
1-10	1.25	1.30	1.40	1.50
20	1.25	1.30	1.40	1.50
30	1.25	1.30	1.40	1.50

### Part Numbering Code

<u>C A</u>	<u>0 5</u>	<u>0 5</u>	<u>D</u>	<u>X X</u>
TYPE	LENGTH	WIDTH	SUBSTRATE	dB VALUE
CA = Chip Attenuator	05 = 0.05"	05 = 0.05"	Diamond	01 - 10 00 - 30



### CA0505D T

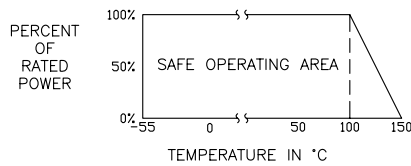


EMC Technology offers a line of CVD Diamond chip attenuators with extreme high power ratings. With operating frequency of DC to 26.5 GHz, these products are ideal for military and space applications because of their high power handling capability, broad frequency response and small footprint. The CA0505D T are manufactured using all thin film construction and have a thin film gold terminations. These units have a gold plated copper tab for ease of installation. Standard chip and high reliability tested versions based on Mil-PRF-55342 are available. Select from tape and reel or waffle packaging. These products are lead free, RoHS compliant and S-level approved. Standard available values are 0 through 10, 20, and 30 dB.

### Specifications

Nominal Impedance	50 Ohms
Frequency Range	DC to 26.5 GHz
Attenuation Values	0 thru 10, 20 and 30 dB
Power Rating	20 Watts
Operating Temperature	-55 °C to 150 °C
Resistive Material	Thin Film
Terminal Material	Thin Film, Gold Solderable or Bondable Finish
Tab	Copper, gold plated

### Power Rating and Derating



### Attenuation Accuracy (dB)

dB VALUE	DC - 8 GHz	8 -12.4 GHz	12.4 - 18 GHz	18 - 26.5 GHz
0	+ 0.25	+ 0.30	+ 0.50	+ 0.70
1 - 3	± 0.25	± 0.30	± 0.50	± 0.50
4 - 6	± 0.25	± 0.30	± 0.50	± 0.75
7 - 10	± 0.25	± 0.30	± 0.50	± 1.00
20	± 0.50	± 0.50	± 0.75	± 1.00
30	± 0.50	± 0.50	± 1.00	± 1.50

### VSWR (Max)

dB VALUE	DC - 8 GHz	8 -12.4 GHz	12.4 - 18 GHz	18 - 26.5 GHz
0	1.25	1.30	1.40	1.50
1-10	1.25	1.30	1.40	1.50
20	1.25	1.30	1.40	1.50
30	1.25	1.30	1.40	1.50

### Part Numbering Code

<u>CA</u>	<u>05</u>	<u>05</u>	<u>D</u>	<u>XX</u>	<u>FT</u>
TYPE	LENGTH	WIDTH	SUBSTRATE	dB VALUE	MOUNTING
CA = Chip Attenuator	05 = 0.05"	05 = 0.05"	Diamond	01 - 10	(blank) = Chip FT = Flange & Tab T = Tab

# Diamond Rf Resistives®

## Diamond Flange Attenuator



EMC Technology offers a line of CVD Diamond chip attenuators with extreme high power ratings. With operating frequency of DC to 26.5 GHz, these products are ideal for military and space applications because of their high power handling capability, broad frequency response and small footprint. The CA0505D FT is manufactured using all thin film construction with gold finish. These units are equipped with a gold plated copper tab and integrated heat sink for ease of installation. Standard chip and high reliability tested versions based on MIL-PRF-55342 are available. Select from tape and reel or waffle packaging. These products are lead free, RoHS compliant and S-level approved. Standard available values are 1 through 10, 20 and 30 dB.

### Specifications

Nominal Impedance	50 Ohms
Frequency Range	DC to 26.5 GHz
Attenuation Values	1 thru 10, 20 and 30 dB
Power Rating	20 Watts
Operating Temperature	-55 °C to 150 °C
Resistive Material	Thin Film
Terminal Material	Thin Film, Gold Solderable or Bondable Finish
Tab	Copper, gold plated
Heat Sink	Copper, gold plated

#### Attenuation Accuracy (dB)

dB VALUE	DC - 8 GHz	8 -12.4 GHz	12.4 - 18 GHz	18 - 26.5 GHz
0	+ 0.25	+ 0.30	+ 0.50	+ 0.70
1 - 3	± 0.25	± 0.30	± 0.50	± 0.50
4 - 6	± 0.25	± 0.30	± 0.50	± 0.75
7 - 10	± 0.25	± 0.30	± 0.50	± 1.00
20	± 0.50	± 0.50	± 0.75	± 1.00
30	± 0.50	± 0.50	± 1.00	± 1.50

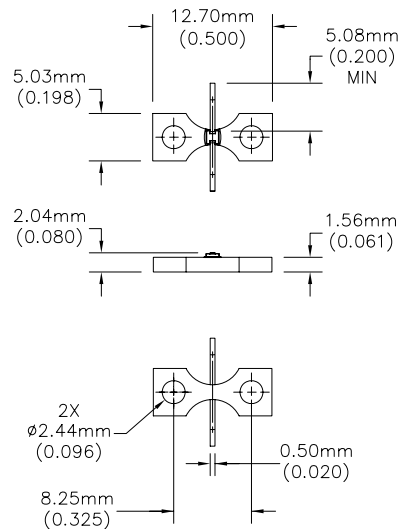
#### VSWR (Max)

dB VALUE	DC - 8 GHz	8 -12.4 GHz	12.4 - 18 GHz	18 - 26.5 GHz
0	1.25	1.30	1.40	1.50
1-10	1.25	1.30	1.40	1.50
20	1.25	1.30	1.40	1.50
30	1.25	1.30	1.40	1.50

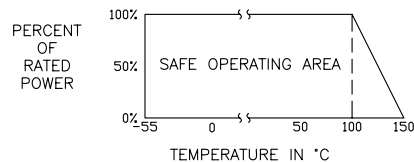
### Part Numbering Code

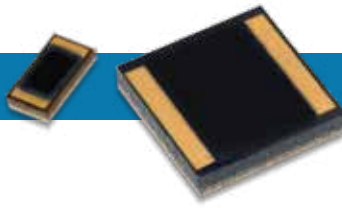
<u>C A</u>	<u>0 5</u>	<u>0 5</u>	<u>D</u>	<u>X X</u>	<u>F T</u>
TYPE	LENGTH	WIDTH	SUBSTRATE	dB VALUE	MOUNTING
CA = Chip Attenuator	05 = 0.05"	05 = 0.05"	Diamond	01 - 10	(blank) = Chip FT = Flange & Tab T = Tab

### CA0505D FT

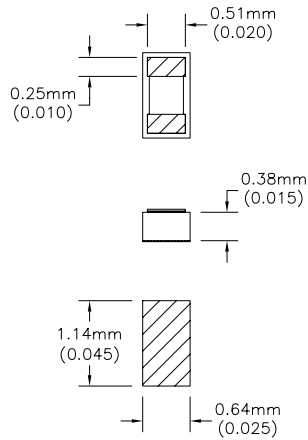


### Power Rating and Derating

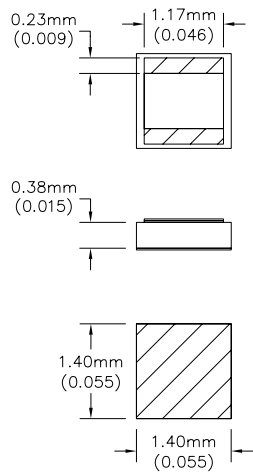




**CR0402D**



**CR0505D**

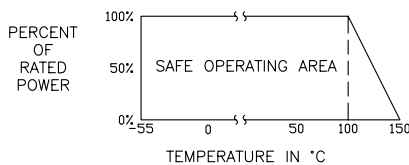


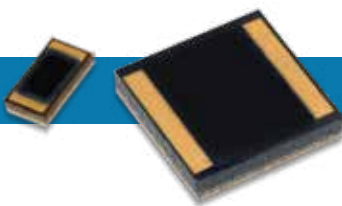
EMC Technology surface mount (CR) chip resistors with extreme high power ratings may be used in applications from DC to 30.0 GHz and are ideal for military and space applications because of their high power capability, broad frequency response and small, light-weight size. They are manufactured using all thin film construction and have a thin film gold finish that is both wire bondable and solderable. Because of their total thin film construction they are ideal for peak power applications. Standard chip and high reliability tested versions based on Mil-PRF-55342 are also available. Select from tape and reel, bulk, or waffle packaging. These products are lead free, RoHS compliant and S-level approved. Standard available values are 50 & 100 ohms. Contact us directly for non-standard resistance values.

**Specifications**

Resistance Values	Part Series	50 and 100 Ohms +/-5%
Frequency Range	CR0402D/W2	DC to 30 GHz
	CR0505D	DC - 18.0 GHz
	CR0603D	DC - 18.0 GHz
	CR1010D	DC - 18.0 GHz
Power Rating	CR0402D/W2	20 Watts
	CR0505D	50 Watts
	CR0603D	50 Watts
	CR1010D	125 Watts
Typical Capacitance	CR0402D/W2	0.09pF
	CR0505D	0.1pF
	CR0603D	0.19pF
	CR1010D	0.8pF
Operating Temperature	All	-55 °C to 150 °C
Resistive Material	All	Thin Film
Terminal Material	All	Thin Film, Gold Solderable or Bondable Finish

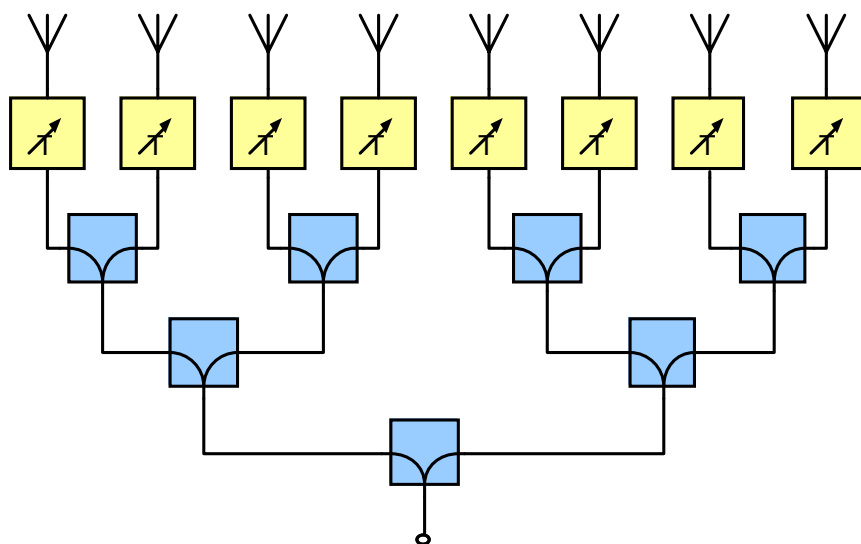
**Power Rating and Derating**





### Reduce the Size and Weight of Phased Array Radar Feed Network Easily

Corporate-feed networks in phased array radars have benefited from the small footprint, high power handling, and excellent high-frequency characteristics of Diamond Rf resistors. The use of Diamond Rf resistors such as CR0505D, in place of the traditionally larger components, has significantly reduced the size and weight of the feed network without compromising power handling and thermal performance.

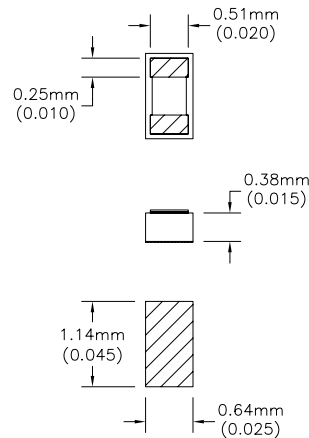


### Part Numbering Code

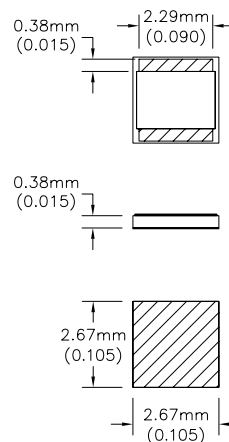
<b>C R</b>	<b>1 0</b>	<b>1 0</b>	<b>D</b>	<b>5 0 . 5</b>	<b>W 2</b>
<u>TYPE</u>	<u>LENGTH</u>	<u>WIDTH</u>	<u>SUBSTRATE MATERIAL</u>	<u>OHMS</u>	<u>TOLERANCE</u>
CR = Chip Resistor	04 = 0.04" 05 = 0.05" 06 = 0.06" 10 = 0.10"	02 = 0.02" 05 = 0.05" 03 = 0.03" 10 = 0.10"	D = CVD Diamond	50 = 50 OHMS 100 = 100 OHMS	(blank) = Chip Only W2 = Double Wrap
				5 = 5%	

Note: Other ohms values available on request. Please contact our Sales department.

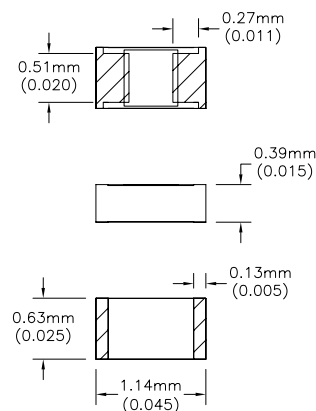
### CR0603D



### CR1010D

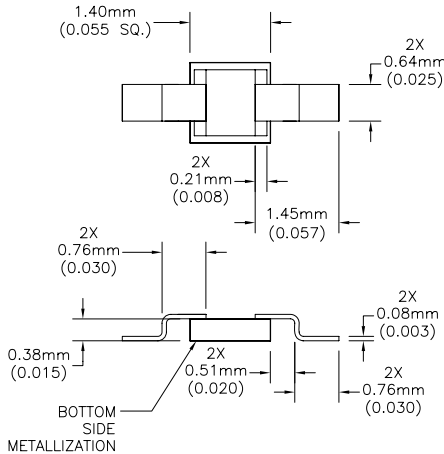


### CR0402D W2

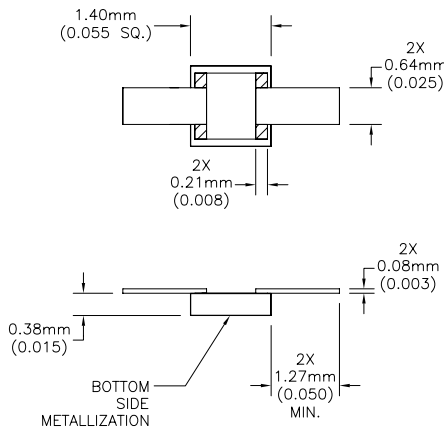




### CR0505DTB



### CR0505DT2

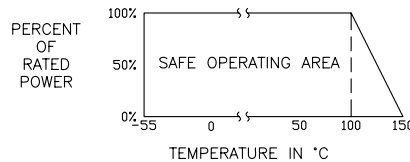


CVD Diamond surface mount (CR) chip resistors with extreme high power ratings. These resistors may be used in applications from DC to 30.0 GHz and are ideal for military and space applications because of their high power capability, broad frequency response and small, light-weight size. These terminations are available in easy to mount double wrap and tab mount units. They are manufactured using all thin film construction and have a pure thin film gold finish that is both wire bondable and solderable. They can be supplied with or without solderable tabs.

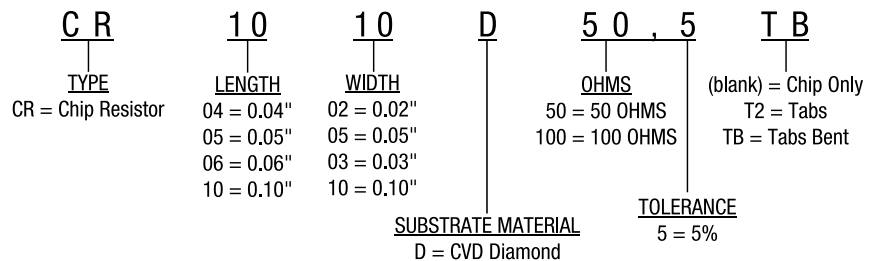
### Specifications

Resistance Values	50 and 100 Ohms +/-5%
Frequency Range	30.0 GHz
Power Rating	50 Watts
Typical Capacitance	0.1pF
Operating Temperature	-55 °C to 150 °C
Resistive Material	Thin Film
Terminal Material	Thin Film, Gold Solderable or Bondable Finish
Tab	Copper, Gold Plated

### Power Rating and Derating



### Part Numbering Code



Note: Other ohm values available on request. Please contact our Sales department.

# Diamond Rf Resistives®

## Diamond Chip Termination

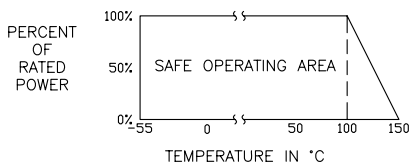


Our exclusive line of CVD Diamond chip terminations offers a unique combination of extreme high power ratings in very small packages. These terminations may be used in applications from DC to 28.0 GHz and are ideal for military and space applications because of their high power capability and small, light-weight package size. The terminations are manufactured using all thin film construction and have a gold finish that is both wire bondable and solderable. This total thin film construction also makes them ideal for peak power applications. High reliability tested versions based on Mil-PRF-55342 are also available. Select from tape and reel, bulk, or wafer packaging. These products are also lead free, RoHS compliant and S-level approved.

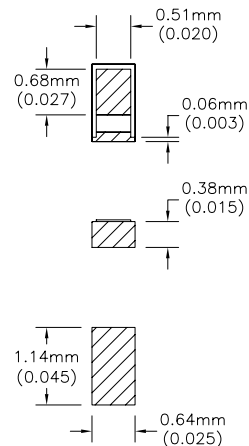
### Specifications

Impedance	Part Series	50 Ohms +/-5%
Frequency Range	CT0402D	DC to 8 GHz
	CT0505D	DC to 20 GHz
	CT0603D	DC to 28 GHz
	CT1310D	DC to 14 GHz
Power Rating	CT0402D	10 Watts
	CT0505D	50 Watts
	CT0603D	50 Watts
	CT1310D	150 Watts
VSWR	All	1.6:1 Max
Operating Temperature	All	-55 °C to 150 °C
Resistive Material	All	Thin Film
Terminal Material	All	Thin Film, Gold Solderable or Bondable Finish

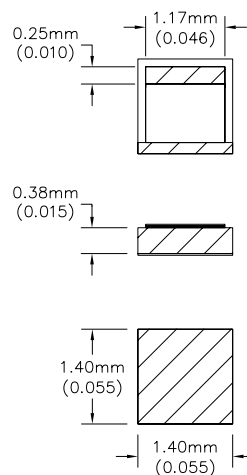
### Power Rating and Derating



#### CT0402D



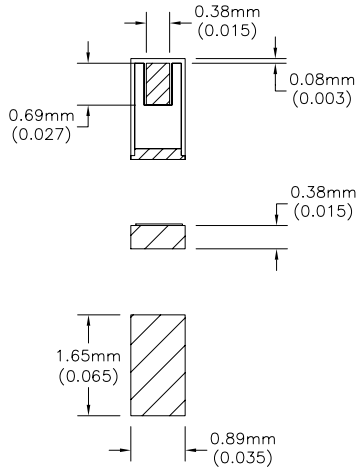
#### CT0505D



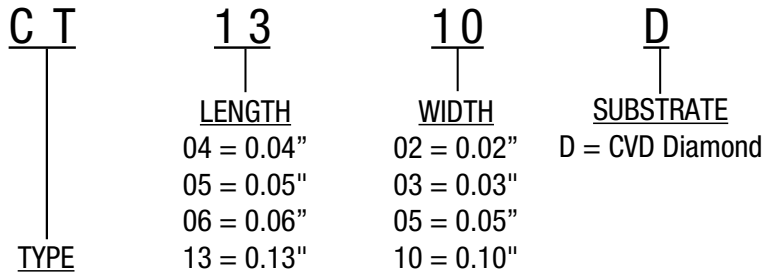




**CT0603D**



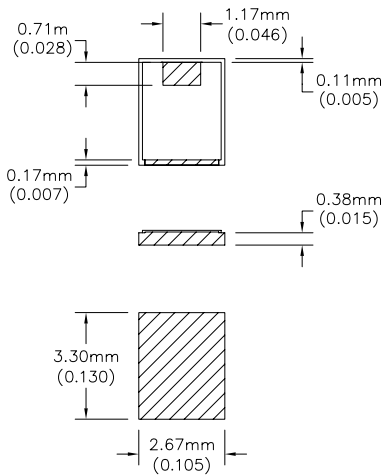
**Part Numbering Code**



CT = Chip Terminations

*Note: Not every combination of size is available.*

**CT1310D**



# Diamond Rf Resistives®

## Diamond Flange & Tabbed Termination



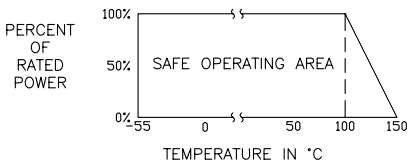
Our exclusive line of CVD Diamond chip terminations offers a unique combination of extreme high power ratings in very small packages. These terminations may be used in applications from DC to 26.5 GHz and are ideal for military and space applications because of their high power capability, broad frequency response and small, light-weight package size. These terminations are available in easy to mount tab and flange mount units.

They are ideal for peak power applications. They are manufactured using all thin film construction and have a pure thin film gold finish that is both wire bondable and solderable. They can be supplied with or without solderable tabs. High reliability tested versions based on MIL-PRF-55342 are also available. These products are lead free, RoHS compliant and S-level approved. They also meet NASA out-gassing requirements for space applications.

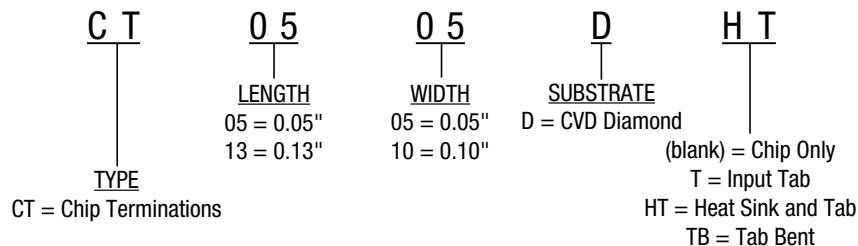
### Specifications

Impedance	50 Ohms +/-5%
Frequency Range	DC to 20 GHz
Power Rating	50 - 150 Watts
VSWR	1.6:1 Max
Operating Temperature	-55 °C to 150 °C
Resistive Material	Thin Film
Terminal Material	Thin Film, Gold Solderable or Bondable Finish
Tab	Copper, gold plated
Heat sink [HT only]	Copper, gold plated

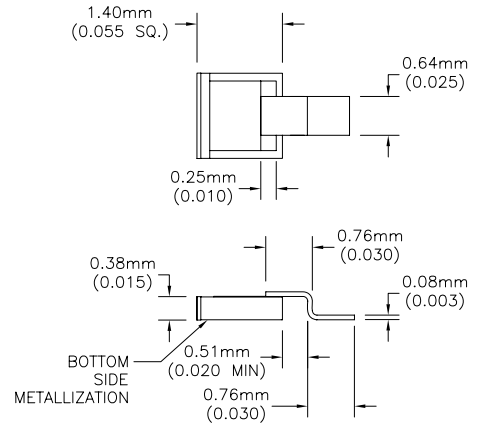
### Power Rating and Derating



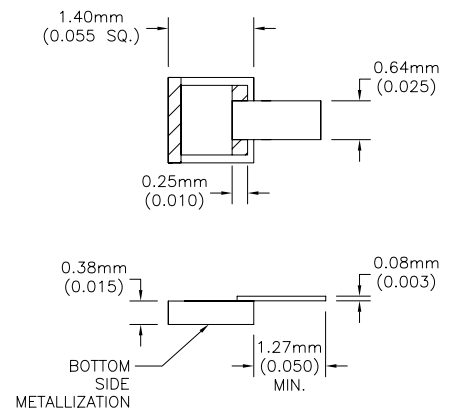
### Part Numbering Code



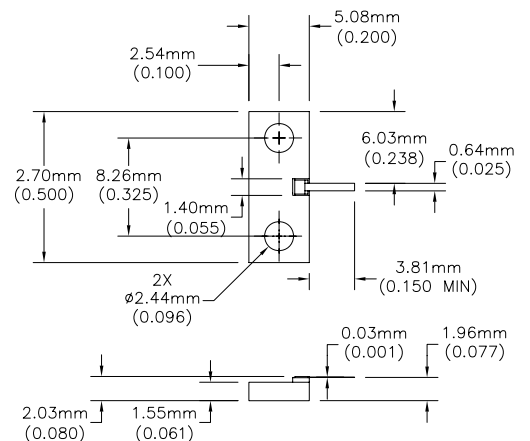
### CT0505DTB



### CT0505DT



### CT0505DHT

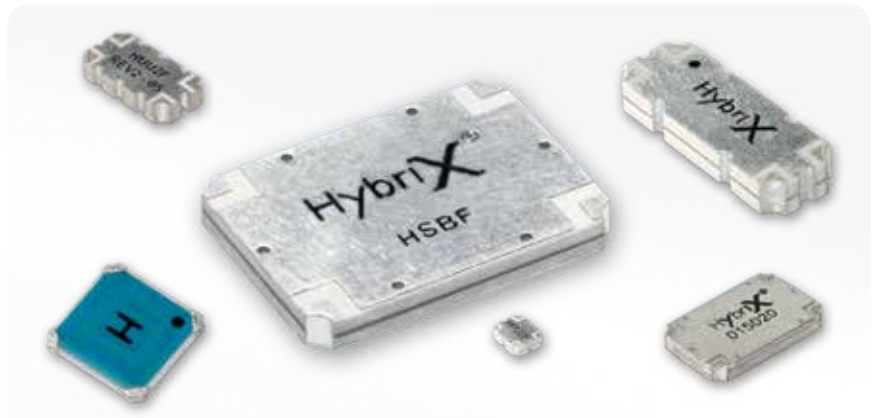


## Features

- Frequency Ranges from 48 MHz to 18 GHz.
- Surface Mountable
- Very Small Footprints (6mm x 3mm Available)
- High Power Handling (up to 500 W)
- Low Insertion Loss
- Excellent Isolation and VSWR
- 90° Quadrature
- Multilayered PTFE or Ceramic Construction
- Non-magnetic Products Available
- RoHS Compliant
- Tape and Reel Packaging

## Applications

- W-CDMA, UMTS, WiMAX, and LTE Base Stations
- Satellite Communication
- MRI and Spectroscopy
- Combiners and Splitters
- Duplexers
- Matched Phase Shifter
- Mixers
- Modulators
- Narrow Band GPS
- Signal Distribution Nodes



HybriX® 3 dB Hybrid Couplers are made for applications which require high isolation and low insertion loss. They are surface mountable and packaged in tape and reels. HybriX® Hybrid Couplers have a small footprint, low profile, and are RoHS compliant.

### Quick Selector Chart

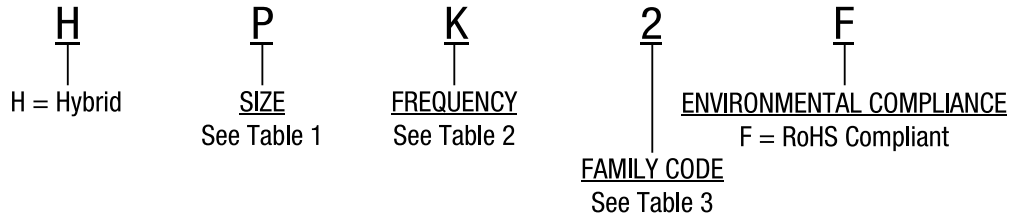
Frequency (MHz)	Applications	Part Number	Power (Watts)	Dimensions (mm)
360 - 560	TETRA	HDC2F	200	14.22 x 8.89
470 - 860	Broadcast	HLB2F	500	34.04 x 17.02
700 - 1000	LTE-FDD, GSM, Public Safety	HPD2TF	200	6.35 x 5.08
1200 - 1700	GPS, LTE-FDD	HPG2F	80	6.35 x 5.08
1700 - 2200	LTE, PCS, AWS, GSM-1800, UMTS	HPK2F	100	6.35 x 5.08
2300 - 2700	WiMAX, LTE-TDD	HPP2F	35	6.35 x 5.08
		HDS2F	200	14.22 x 8.89
3300 - 3900	WiMAX, LTE	HPR2F	60	6.35 x 5.08
		HDS2F	200	14.22 x 8.89
8000 - 12000	PTP, Radar, Satellite	HPX2F	20	6.35 x 5.08
15000 - 18500	PTP, Radar, Satellite	HN05W03F	50	4.44 x 4.44

# HybriX® 3 dB Hybrid Couplers

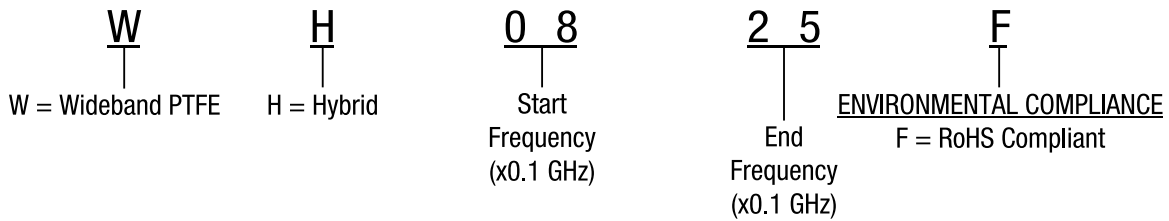
## General Specifications



### Part Numbering Code - HybriX® 3 dB Hybrid



### Part Numbering Code - Wideband HybriX® 3 dB Hybrid

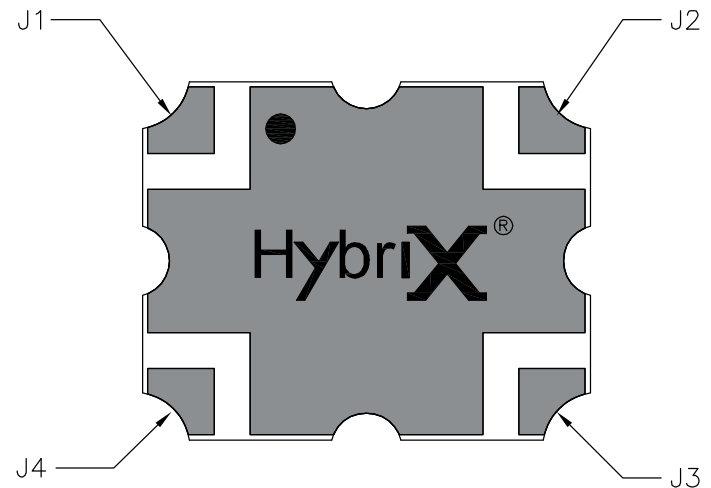


Code	Dimensions (mm)	Dimensions (in)
A	25.40 x 12.70	1.000 x 0.500
S	16.51 x 12.19	0.650 x 0.480
M	14.22 x 5.08	0.560 x 0.200
D	14.22 x 8.89	0.560 x 0.350
L	34.04 x 17.02	1.340 x 0.670
P	6.35 x 5.08	0.250 x 0.200
F	6.00 x 3.00	0.236 x 0.118
E	25.40 x 25.40	1.000 x 1.000
U	10.16 x 5.08	0.400 x 0.200

Code	Frequency Range (GHz)	Code	Frequency Range (GHz)
A	0.15 - 0.25	M	2.0 - 2.5
B	0.47 - 0.86	N	2.0 - 2.7
C	0.38 - 0.52	O	2.4 - 2.8
D	0.81 - 0.96	P	2.3 - 2.7
E	1.0 - 2.0	Q	2.7 - 3.2
F	0.96 - 1.22	R	3.4 - 3.6
G	1.4 - 1.7	S	2.0 - 4.0
H	1.5 - 2.0	T	0.69 - 0.91
I	4.3 - 4.7	U	5.0 - 6.0
J	1.7 - 2.0	V	0.7 - 1.0
K	1.9 - 2.2	W	15.0 - 18.0
L	2.0 - 2.3	Y	18.0 - 27.0

Code	Description
(blank)	Multi-layer PTFE with Internal Vias
2	Multi-layer PTFE with Castellated Vias
2T	Multi-layer PTFE with Castellated Vias; Enhanced Performance
3	<b>HYBRIX</b> LTCC with Castellated Vias

### Pin Configuration



J1	J2	J3	J4
Input	Isolated	Out, 90°	Coupled, 0°
Isolated	Input	Coupled, 0°	Output, 90°
Output, 90°	Coupled, 0°	Input	Isolated
Coupled, 0°	Output, 90°	Isolated	Input



# HybriX® 3 dB Hybrid Couplers

## Product Information

Frequency GHz		L		W		H	Isolation	Insertion Loss	VSWR	Amplitude Balance	Phase Balance	Average Power*	Core Material	Model Number	
Min	Max	mm [inches]					dB Min	dB Max	Max:1	dB Max	deg Max	Watts CW			
.048	.084	50.80	[2.000]	38.10	[1.500]	4.47	[.176]	20	0.20	1.20	0.25	± 2.0	300	PTFE	HG064M2F
.059	.069	14.22	[0.560]	8.89	[0.350]	2.01	[.079]	20	1.00	1.30	0.10	± 2.0	10	LTCC	HD064M3F
.088	.108	46.48	[1.830]	51.05	[2.010]	4.57	[.180]	23	0.25	1.20	0.25	± 2.0	600	PTFE	H88-108-600
.123	.133	14.22	[0.560]	8.89	[0.350]	2.01	[.079]	20	0.80	1.35	0.20	± 2.0	10	LTCC	HD128M3F
.123	.133	25.40	[1.000]	25.40	[1.000]	1.98	[.078]	28	0.23	1.10	0.10	± 1.0	300	PTFE	HE128MF
.150	.175	25.40	[1.000]	25.40	[1.000]	1.98	[.078]	20	0.30	1.20	0.25	± 2.0	200	PTFE	HEAF
.293	.303	25.40	[1.000]	25.40	[1.000]	1.98	[.078]	35	0.17	1.07	0.10	± 1.0	300	PTFE	HE298MF
.360	.560	14.22	[0.560]	8.89	[0.350]	1.12	[.044]	25	0.16	1.20	0.35	± 2.0	200	PTFE	HDC2F
.380	.520	16.51	[0.650]	12.19	[0.480]	1.94	[.076]	23	0.25	1.20	0.50	± 2.0	200	PTFE	HSAF
.400	.500	25.40	[1.000]	25.40	[1.000]	1.98	[.078]	25	0.20	1.15	0.40	± 3.0	300	PTFE	HE450M2F
.410	.860	14.22	[0.560]	8.89	[0.350]	1.52	[.060]	24	0.25	1.20	0.45	± 2.0	200	PTFE	HDB2F
.470	.860	16.51	[0.650]	12.19	[0.480]	1.80	[.071]	19	0.25	1.30	0.40	± 2.0	200	PTFE	HSBF
.470	.860	34.04	[1.340]	17.02	[0.670]	4.11	[.162]	20	0.12	1.20	0.50	± 2.0	500	PTFE	HLB2F
.500	3.400	50.01	[1.969]	10.01	[0.394]	3.51	[.318]	25	0.15	1.15	0.90	± 3.0	100	PTFE	WH0530TF
.690	.910	14.22	[0.560]	8.89	[0.350]	1.93	[.076]	25	0.20	1.15	0.20	± 1.0	200	PTFE	HDT2F
.700	1.000	14.22	[0.560]	8.89	[0.350]	1.91	[.075]	24	0.24	1.20	0.38	± 1.5	200	PTFE	HDV2F
.700	1.000	6.35	[0.250]	5.08	[0.200]	1.50	[.060]	25	0.12	1.12	0.20	± 2.0	200	PTFE	HPD2TF
.800	1.000	6.35	[0.250]	5.08	[0.200]	1.91	[.075]	20	0.35	1.20	0.25	± 2.0	80	PTFE	HPD2F
.811	1.000	14.22	[0.560]	8.89	[0.350]	1.91	[.075]	26	0.15	1.15	0.30	± 2.0	200	PTFE	HDDF
1.000	2.000	14.22	[0.560]	8.89	[0.350]	1.30	[.051]	20	0.20	1.20	0.55	± 2.0	200	PTFE	HDE
1.200	1.720	6.35	[0.250]	5.08	[0.200]	1.52	[.060]	22	0.23	1.20	0.25	± 2.5	80	PTFE	HPG2F
1.700	2.000	14.22	[0.560]	8.89	[0.350]	1.91	[.075]	24	0.12	1.16	0.20	± 2.0	200	PTFE	HDJ2F
1.700	2.000	14.22	[0.560]	5.08	[0.200]	1.85	[.073]	25	0.12	1.14	0.20	± 2.0	100	PTFE	HMJ2F
1.700	2.000	6.35	[0.250]	5.08	[0.200]	1.85	[.073]	22	0.20	1.22	0.40	± 3.5	100	PTFE	HPJ2F
1.700	2.400	6.35	[0.250]	5.08	[0.200]	1.85	[.073]	23	0.20	1.20	0.30	± 3.0	100	PTFE	HPK2F
1.700	2.700	14.22	[0.560]	5.08	[0.200]	2.44	[.096]	26	0.15	1.15	0.20	± 2.0	100	PTFE	WH1727F
2.000	2.300	14.22	[0.560]	5.08	[0.200]	1.88	[.074]	25	0.11	1.12	0.20	± 2.0	100	PTFE	HML2F
2.000	2.300	6.35	[0.250]	5.08	[0.200]	1.85	[.073]	22	0.20	1.22	0.30	± 3.0	100	PTFE	HPL2F
2.000	4.000	14.22	[0.560]	8.89	[0.350]	1.40	[.055]	20	0.20	1.30	0.50	± 4.0	200	PTFE	HDS2F
2.300	2.700	14.22	[0.560]	5.08	[0.200]	1.88	[.074]	23	0.11	1.17	0.15	± 2.0	80	PTFE	HMP2F
2.300	2.700	6.35	[0.250]	5.08	[0.200]	1.85	[.073]	23	0.21	1.23	0.30	± 3.0	35	PTFE	HPP2F
2.700	3.200	6.35	[0.250]	5.08	[0.200]	1.85	[.073]	23	0.18	1.15	0.20	± 3.0	50	PTFE	HPQ2F
2.700	3.500	14.22	[0.560]	5.08	[0.200]	1.40	[.055]	24	0.20	1.25	0.40	± 3.0	200	PTFE	HMR2F
3.000	4.500	6.35	[0.250]	5.08	[0.200]	1.42	[.056]	24	0.18	1.15	0.40	± 3.0	60	PTFE	HPR2F
3.600	6.400	6.35	[0.250]	5.08	[0.200]	1.42	[.056]	23	0.45	1.30	0.35	± 3.0	50	PTFE	HPU2F
8.000	12.000	6.35	[0.250]	5.08	[0.200]	1.42	[.056]	18	0.50	1.45	0.40	± 6.0	20	PTFE	HPX2F
15.000	18.500	4.44	[0.175]	4.44	[0.175]	.38	[.015]	20	0.50	1.50	0.50	± 10.0	50	Alumina	HN05Z03F
15.000	18.500	4.44	[0.175]	4.44	[0.175]	.38	[.015]	18	0.70	1.50	0.60	± 10.0	50	Alumina	HN05W03F

\* at 85 °C Operating Temperature

# HybriX® 3 dB Hybrid Couplers

## Cross Reference Chart



### HYBRIX® HYBRID COUPLER CROSS REFERENCE CHART

FREQUENCY (GHZ)	SIZE		POWER (W) <sup>1</sup>	HYBRIX	ANAREN
	(MM)	(IN)			
0.048 - 0.084	50.80 x 38.10	2.00 x 1.50	300	HG064M2F	
0.059 - 0.069	14.22 x 8.89	0.56 x 0.35	10	HD064M3F	
0.123 - 0.133	25.40 x 25.40	1.00 x 1.00	300	HE128MF	
	14.22 x 8.89	0.56 x 1.00	10	HD128M3F	
0.293 - 0.303	25.40 x 25.40	1.00 x 1.00	300	HE298MF	
0.380 - 0.520	16.51 x 12.19	0.65 x 0.48	200	HSAF	11303-3
	14.22 x 8.89	0.56 x 0.35	200	HDC2F	
0.400 - 0.500	25.40 x 25.40	1.00 x 1.00	300	HE450M2F	
0.410 - 0.480	14.22 x 8.89	0.56 x 0.35	45		XC0450A-03S
0.470 - 0.860	34.04 x 17.02	1.34 x 0.67	500	HLB2F	
	16.51 x 12.19	0.65 x 0.48	200	HSBF	1F1304-3
0.620 - 0.900	6.35 x 5.08	0.25 x 0.20	180		X3C07P1-03
0.800 - 1.000	14.22 x 8.89	0.56 x 0.35	200	HDDF	XC0900A-03S
	14.22 x 5.08	0.56 x 0.20	100	HMD2F	XC0900E-03S
	6.35 x 5.08	0.25 x 0.20	200	HPD2TF	X3C09P2-03
	6.35 x 5.08	0.25 x 0.20	80	HPD2F	X3C09P1-03
1.000 - 2.000	14.22 x 8.89	0.56 x 0.35	200	HDE	11305-3S
1.200 - 1.700	14.22 x 8.89	0.56 x 0.35	100		1E1305-3
1.700 - 2.000	14.22 x 8.89	0.56 x 0.35	200	HDJ2F	XC1900A-03S
	14.22 x 5.08	0.56 x 0.20	100	HMJ2F	XC1900E-03S
	6.35 x 5.08	0.25 x 0.20	200	HPJ2TF	X3C19P2-03
	6.35 x 5.08	0.25 x 0.20	100	HPK2F	X3C19P1-03
2.000 - 2.300	25.40 x 12.70	1.00 x 0.50	300		S03B2150N3
	14.22 x 8.89	0.56 x 0.35	200		XC2100A-03S
	14.22 x 5.08	0.56 x 0.20	100	HML2F	XC2100E-03S
	6.35 x 5.08	0.25 x 0.20	200		
	6.35 x 5.08	0.25 x 0.20	100	HPK2F	X3C21P1-03
2.000 - 4.000	14.22 x 8.89	0.56 x 0.35	60		11306-3S
2.100 - 2.400	6.00 x 3.00	0.24 x 0.12	20		
2.300 - 2.700	25.40 x 12.70	1.00 x 0.50	300		
	14.22 x 8.89	0.56 x 0.35	200		XC2500A-03S
	14.22 x 5.08	0.56 x 0.20	80	HMP2F	XC2500E-03S
	6.35 x 5.08	0.25 x 0.20	35	HPP2F	1P603S
2.700 - 3.200	6.35 x 5.08	0.25 x 0.20	50	HPQ2F	
3.000 - 4.500	6.35 x 5.08	0.25 x 0.20	60	HPR2F	XC3500P-03S
3.600 - 6.400	6.35 x 5.08	0.25 x 0.20	50	HPU2F	
5.000 - 6.000	10.16 x 5.08	0.40 x 0.20	25		1M803S
8.000 - 12.000	6.35 x 5.08	0.25 x 0.20	20	HPX2F	

1: Power rating pertains only to HybriX® couplers. Anaren products may not be specified to handle same level of power.

### Features

- Frequency Ranges up to 18 GHz.
- Surface Mountable
- Very Small Footprints (6mm x 3mm Available )
- High Power Handling
- Low Insertion Loss
- Excellent Directivity and VSWR
- Internally Terminated Models Available
- Multilayered PTFE or Ceramic Construction
- Non-magnetic Products Available
- RoHS Compliant
- Tape and Reel Packaging

### Applications

- W-CDMA, UMTS, WiMAX, and LTE Base Stations
- Power Monitors
- Reflectometers
- Hybrid Amplifiers



HybriX® Directional Couplers are made for applications which require high directivity and low insertion loss. They are surface mountable and available in tape and reel packaging. HybriX® Directional Couplers have a small footprint, low profile, and are RoHS compliant.

### Quick Selector Chart

Frequency (MHz)	Applications	Part Number	Power (Watts)	Dimensions (mm)
700 - 1000	LTE-FDD, GSM, Public Safety	D3PVxxF	180	6.35 x 5.08
		D3MDxxF	230	14.22 x 5.08
1700 - 2300	LTE, PCS, AWS, GSM-1800, UMTS	D2PJxxF	80	6.35 x 5.08
		D2PLxxF	80	6.35 x 5.08
2300 - 2700	WiMAX, LTE-TDD	D3PPxxF	80	6.35 x 5.08
5000 - 6000	WiMAX, WLAN	D3FUxxF	20	6.00 x 3.00
15000 - 18500	PTP, Radar, Satellite	DN05W20F	50	4.44 x 4.44

# HybriX® Directional Couplers

## General Specifications



## Part Numbering Codes - HybriX® Directional

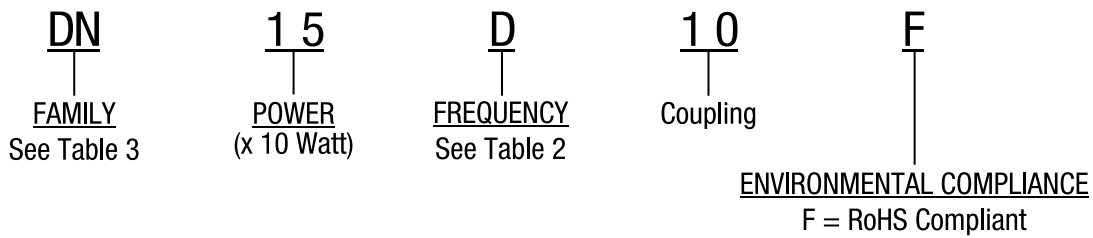
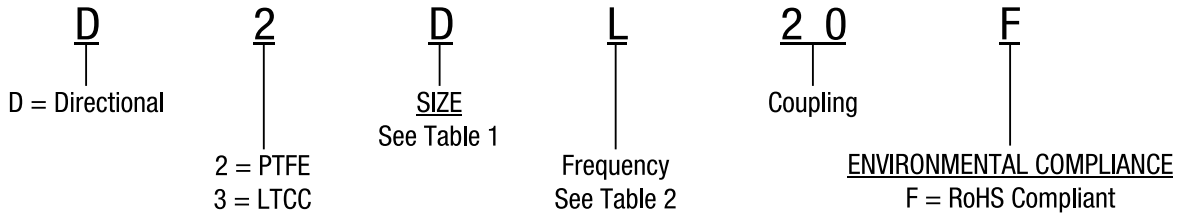
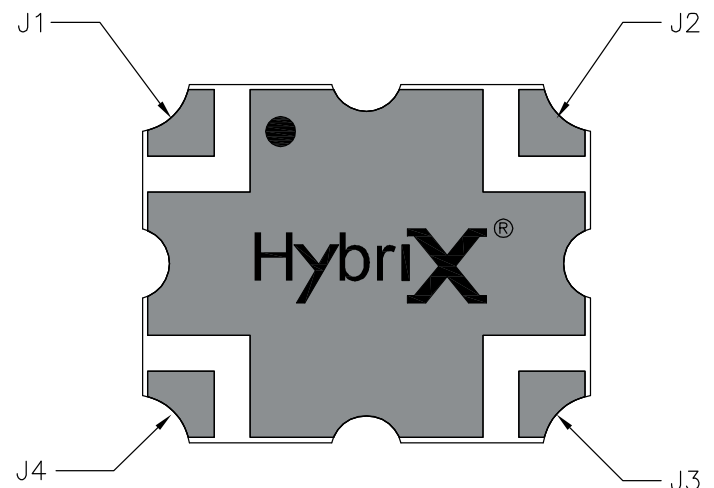


Table 1: Size Code		
A	25.40 x 12.70 mm	1.000 x 0.500 in
S	16.51 x 12.19 mm	0.650 x 0.480 in
M	14.22 x 5.08 mm	0.560 x 0.200 in
D	14.22 x 8.89 mm	0.560 x 0.350 in
L	34.04 x 17.02 mm	1.340 x 0.670 in
P	6.35 x 5.08 mm	0.250 x 0.200 in
F	6.00 x 3.00 mm	0.236 x 0.118 in
E	25.40 x 25.40 mm	1.000 x 1.000 in
U	10.16 x 5.08 mm	0.400 x 0.200 in

Table 2: Frequency Codes (GHz)			
A	0.15 - 0.25	M	2.0 - 2.5
B	0.47 - 0.86	N	2.0 - 2.7
C	0.38 - 0.52	O	2.4 - 2.8
D	0.81 - 0.96	P	2.3 - 2.7
E	1.0 - 2.0	Q	2.7 - 3.2
F	0.96 - 1.22	R	3.4 - 3.6
G	1.4 - 1.7	S	2.0 - 4.0
H	1.5 - 2.0	T	0.69 - 0.91
I	4.3 - 4.7	U	5.0 - 6.0
J	1.7 - 2.0	V	0.7 - 1.0
K	1.9 - 2.2	W	15.0 - 18.0
L	2.0 - 2.3	Y	18.0 - 27.0

Table 3: Family Codes	
D	Directional, PTFE
DN	Directional, No Internal Termination
DS	Directional, with Internal Termination

## Pin Configuration



J1	J2	J3	J4
Input	Output	Isolated	Coupled
Output	Input	Coupled	Isolated
Isolated	Coupled	Input	Output
Coupled	Isolated	Output	Input





# HybriX® Directional Couplers

## Product Information

Frequency	L	W	H	Coupling	Directivity	Insertion Loss	VSWR	Average Power*	Core Material	Model Number
GHz	mm [inches]			dB	dB Min	dB Max	Max:1	Watts CW		
.700 - 1.00	14.22 [.560]	8.89 [.350]	0.64 [.025]	20 ± 1.00	16.00	0.25	1.20	150	Alumina	DS15D20
.700 - 1.00	6.35 [.250]	5.08 [.200]	1.50 [.059]	30 ± 1.50	20.00	0.10	1.15	180	LTCC	D3PV30F
.815 - .960	14.22 [.560]	8.89 [.350]	0.64 [.025]	10 ± 0.50	18.00	0.25	1.17	150	Alumina	DS15D10
.815 - .960	14.22 [.560]	8.89 [.350]	1.54 [.065]	18.90 ± 0.70	35.00	0.30	1.30	150	PTFE	D15D20
1.00 - 2.00	14.22 [.560]	8.89 [.350]	2.59 [.102]	20 ± 1.50	18.00	0.27	1.20	160	PTFE	D2DE20F
1.50 - 2.40	6.35 [.250]	5.08 [.200]	1.83 [.072]	2.0 ± 0.20	20.00	0.25	1.20	150	PTFE	D2PK02F
1.70 - 2.00	6.35 [.250]	5.08 [.200]	1.14 [.045]	5 ± 0.20	25.00	0.12	1.12	200	PTFE	D2PJ05F
1.70 - 2.40	6.35 [.250]	5.08 [.200]	1.42 [.056]	30 ± 2.00	25.00	0.10	1.15	200	PTFE	D2PJ30F
2.00 - 2.30	14.22 [.560]	8.89 [.350]	2.03 [.080]	5 ± 0.19	25.00	0.12	1.12	200	PTFE	D2DL05F
2.00 - 2.30	6.35 [.250]	5.08 [.200]	1.50 [.059]	5 ± 0.30	21.00	0.15	1.22	200	PTFE	D2PL05F
2.00 - 2.30	6.35 [.250]	5.08 [.200]	1.00 [.039]	10 ± 1.00	20.00	0.20	1.20	80	LTCC	D3PL10F
2.00 - 2.70	6.35 [.250]	5.08 [.200]	1.83 [.072]	1.90 ± 0.20	23.00	0.23	1.15	100	PTFE	D2PP02F
2.30 - 2.70	6.35 [.250]	5.08 [.200]	1.00 [.039]	20 ± 1.00	20.00	0.20	1.20	80	LTCC	D3PP20F
14.50 - 19.70	4.45 [.180]	4.45 [.180]	0.38 [.015]	15 ± 2.00	26.00	0.85	1.50	50	Alumina	DN05Z15F
15.00 - 18.50	4.44 [.175]	4.44 [.175]	0.38 [.015]	20 ± 1.50	12.00	0.60	1.60	50	Alumina	DN05W20F

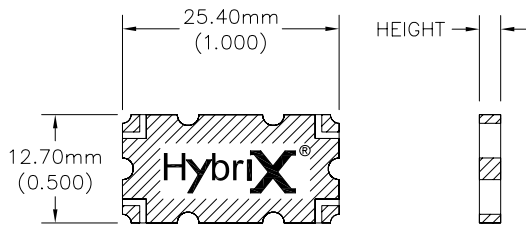
\* at 85 °C Operating Temperature

# HybriX<sup>®</sup> Directional Couplers

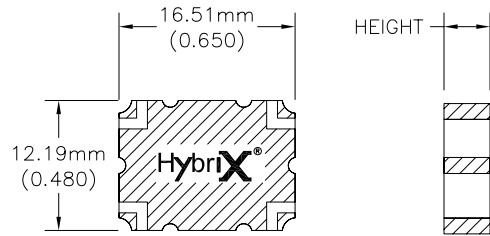
## Mechanical Outlines



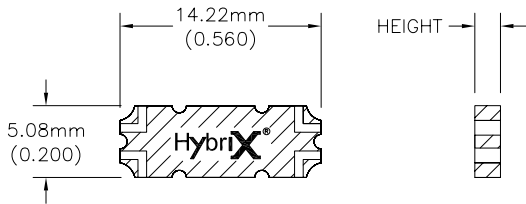
### A Size



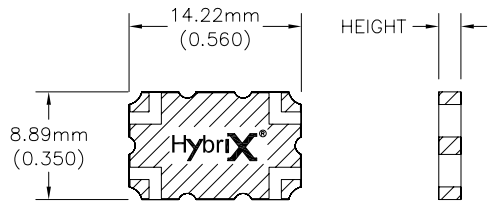
### S Size



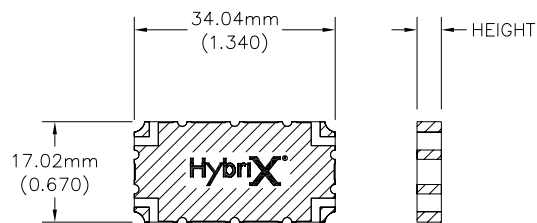
### M Size



### D Size



### L Size

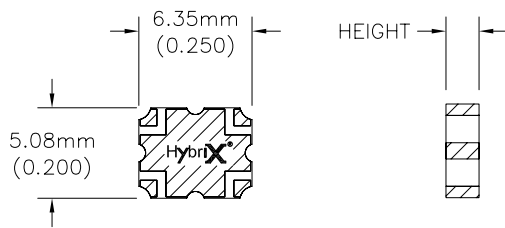




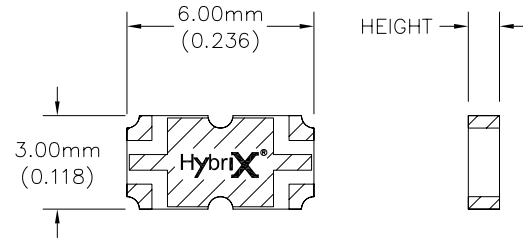
# HybriX® Directional Couplers

## Mechanical Outlines

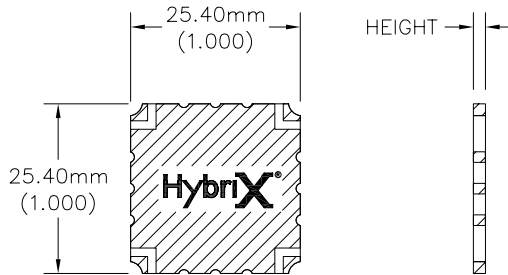
### P Size



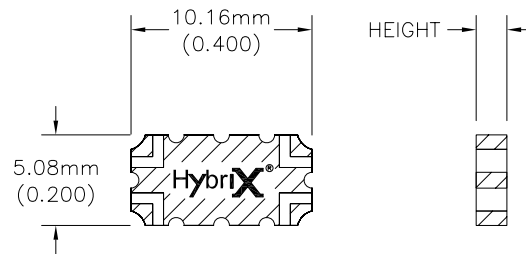
### F Size



### E Size



### U Size



# SMT Crossovers

HybriX® Signal Distribution

## Features

- Excellent Wideband Performance
- Surface Mountable
- Very Low Insertion Loss
- High Power Handling
- High Isolation
- Alumina Construction
- RoHS Compliant
- Tape and Reel Packaging

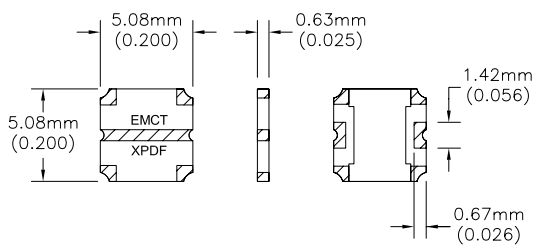
## Applications

- RF / DC Paths Crossing
- RF / RF Paths Crossing

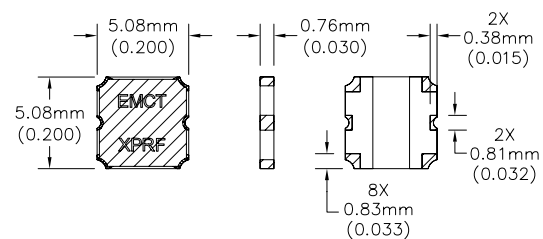


A surface-mount crossover is used when a RF signal must cross a DC line or another RF transmission line. The device provides an easy-to-implement and cost-efficient alternative to RF coaxial cables and multilayer boards. SMT crossovers are packaged in tape and reel and ready for pick-and-place assembly.

### XPDF



### XPRF



## Product Information Table

Frequency GHz	L	W		H		Crossover Type	Insertion Loss	Isolation	VSWR	Average Power*	Material	Model Number	
							dB Max	dB Min	Max:1	Watts CW			
DC - 4 GHz	5.08	[.200]	5.08	[.200]	.64	[.025]	RF - DC	0.05	N/A	1.10	30	Alumina	XPDF
DC - 7 GHz	5.08	[.200]	5.08	[.200]	.64	[.025]	RF - RF	0.05	40	1.10	200	Alumina	XPRF

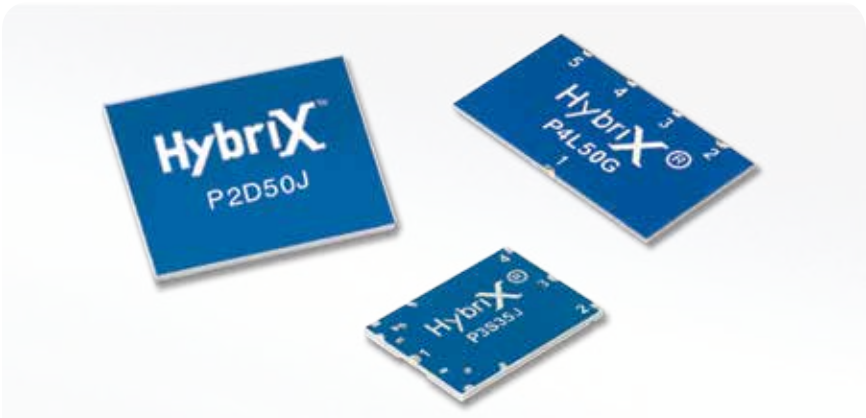
\* at 85 °C Operating Temperature

**Features**

- Products available for 3G and 4G bands
- Surface Mountable
- Small Footprints
- High Power Handling
- Low Insertion Loss
- Excellent Isolation and Low VSWR
- Alumina Construction
- RoHS Compliant
- Tape and Reel Packaging

**Applications**

- LTE, AWS, UMTS, GSM, and PCS Base Stations
- Broadcast
- Antenna Feed Network
- Modulators
- Signal Distribution Nodes
- Combiners and Splitters

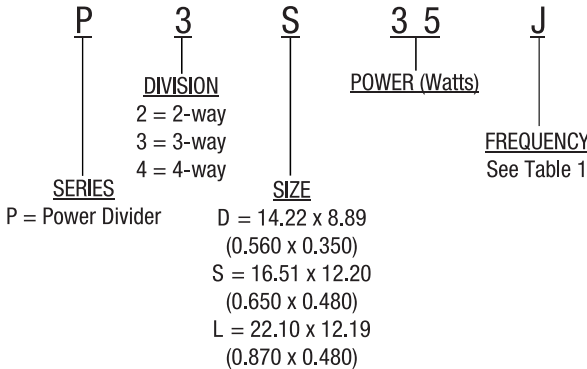


Wilkinson Power Dividers are high power in-phase devices capable of combining and dividing 2-, 3-, and 4-way signals. The devices provide excellent isolation and low VSWR in a small surface-mount package. Products are available for 3G and 4G wireless systems.

**Table 1: Frequency Codes (GHz)**

A	0.15 - 0.25	L	2.0 - 2.3
B	0.47 - 0.86	M	2.0 - 2.5
C	0.38 - 0.52	N	2.0 - 2.7
D	0.81 - 0.96	O	2.4 - 2.8
E	1.0 - 2.0	P	2.3 - 2.7
F	0.96 - 1.22	Q	2.7 - 3.2
G	1.4 - 1.7	R	3.4 - 3.6
H	1.5 - 2.0	S	2.0 - 4.0
I	4.3 - 4.7	T	0.69 - 0.91
J	1.7 - 2.0	U	5.0 - 6.0
K	1.9 - 2.2	V	0.7 - 1.0

**Part Numbering Code**



*Note: All catalog number combinations may not be available. Check with our Sales department before ordering.*

# Power Dividers

## Mechanical Outlines

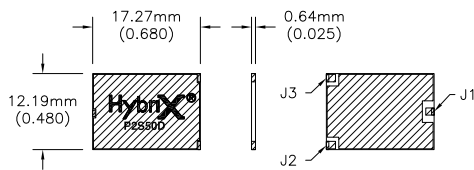


### Product Information Table

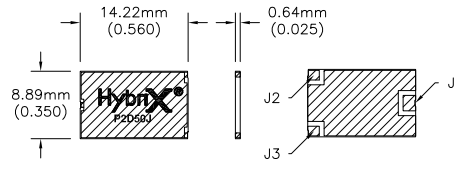
Division	Frequency	L	W	H	Isolation	Insertion Loss	Input VSWR	Output VSWR	Phase Balance	Average Power*	Model Number
	GHz										
2	0.80 - 1.00	16.51 [.650]	12.19 [.480]	0.64 [.025]	16.00	0.30	1.40	1.30	± 2.00	35	P2S35D
2	0.80 - 1.00	16.51 [.650]	12.19 [.480]	0.64 [.025]	16.00	0.30	1.40	1.30	± 2.00	50	P2S50D
2	1.70 - 2.00	14.22 [.560]	8.89 [.350]	0.64 [.025]	20.00	0.30	1.40	1.30	± 2.00	50	P2D50J
3	1.70 - 2.00	16.51 [.650]	12.19 [.480]	0.64 [.025]	19.00	0.30	1.40	1.40	± 7.00	35	P3S35J
3	2.00 - 2.40	16.51 [.650]	12.19 [.480]	0.64 [.025]	16.00	0.30	1.40	1.50	± 8.00	35	P3S35L
4	1.30 - 2.00	22.86 [.900]	12.19 [.480]	0.51 [.020]	13.00	0.85	1.25	1.20	± 7.00	35	P4L35G
4	1.30 - 2.00	22.10 [.870]	12.19 [.480]	0.51 [.020]	13.00	0.85	1.25	1.25	± 7.00	50	P4L50G

\* at 85 °C Operating Temperature

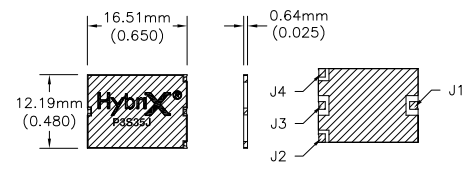
#### P2S50D



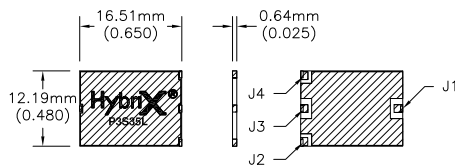
#### P2D50J



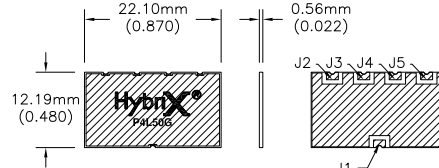
#### P3S35J



#### P3S35L



#### P4L50G

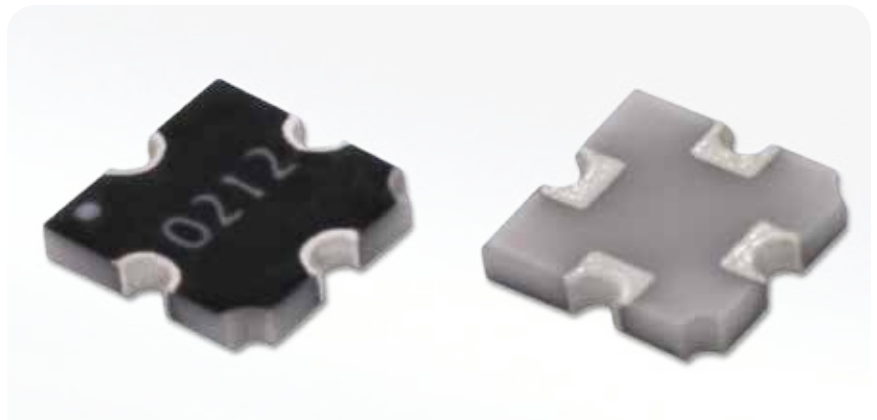


### Features

- Excellent Wideband Performance
- Surface Mountable
- Power Division up to 12 Ways
- Highly Repeatable Performance
- High Thermal Performance
- Robust Construction
- RoHS Compliant
- Tape and Reel Packaging

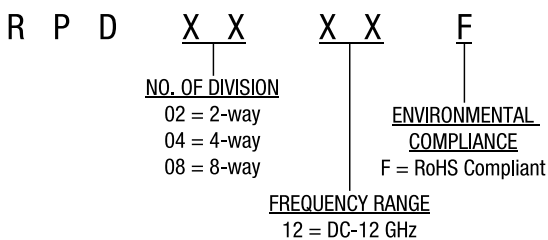
### Applications

- Base Stations
- Instrumentation
- BITE
- Power Monitors
- Antenna Feed

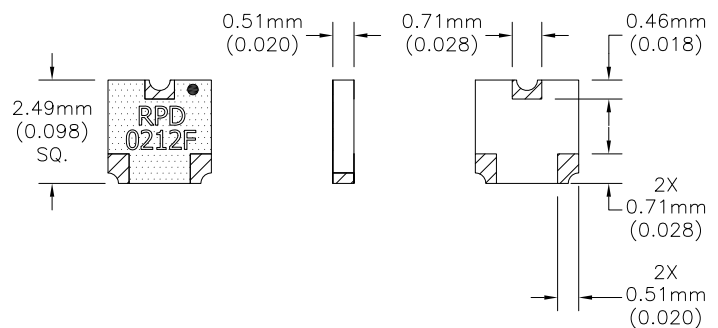


Resistive Power Dividers provide a repeatable power dividing solution and simplifies thermal management compared to on-board design using discrete resistors. Power division up to 12 ways is available. These devices feature a robust construction on alumina substrate and are compatible with pick-and-place assembly.

### Part Numbering Code



### Mechanical Outlines



### Product Information Table

Frequency	L	W	H	No. of Division	Nominal Output	VSWR	Power Handling*	Model Number
GHz	mm [inches]				dB	Typical:1	Watts CW	
DC – 12 GHz	2.49 [.098]	2.49 [.098]	.51 [.020]	2	-6	1.3	1	RPD0212F
DC – 12 GHz	2.49 [.098]	2.49 [.098]	.51 [.020]	3	-10	1.3	1	RPD0312F
DC – 12 GHz	2.49 [.098]	2.49 [.098]	.51 [.020]	4	-12	1.3	1	RPD0412F

\* at 85 °C Operating Temperature

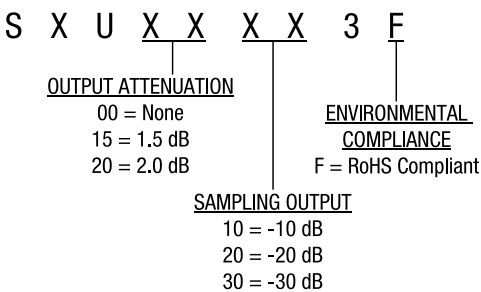
### Features

- Excellent Wideband Performance
- Surface Mountable
- Wide Sampling Output Range
- Optional Built-in Output Attenuator
- High Power Handling
- Alumina Construction
- RoHS Compliant
- Tape and Reel Packaging

### Applications

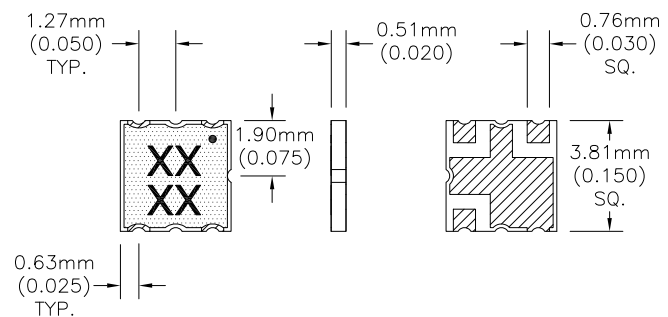
- Base Stations
- Instrumentation
- Power Monitors
- Switch Network
- Antenna Feed

### Part Numbering Code



EMC Technology offers high-performance power samplers in a low-profile surface mount package. Also known as resistive couplers and power tap-off, these devices are an easy-to-implement power sampling solution. Compared to on-board tap-off circuits utilizing discrete resistors, the power samplers offer many advantages including compact footprint, repeatable performance, and reduced BOM.

### Mechanical Outlines

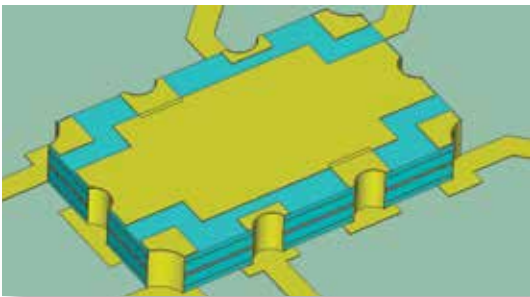


### Product Information Table

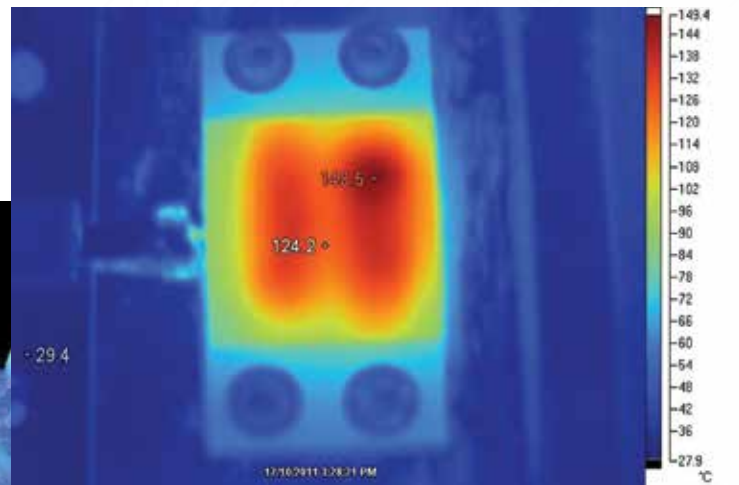
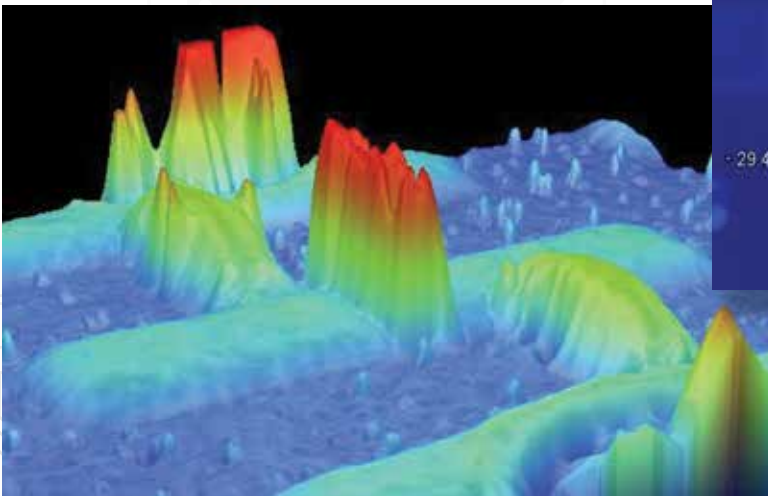
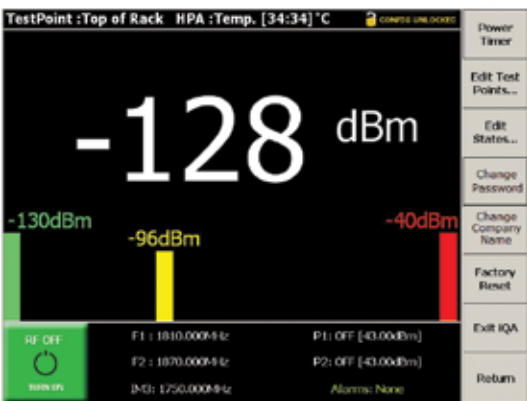
Frequency	L	W	H	Sampling Output	Output Attenuation	VSWR	Power Handling*	Model Number
GHz	mm [inches]			dB	dB	Typical:1	Watts CW	
DC - 4 GHz	3.81 [.150]	3.81 [.150]	.51 [.020]	-20	0	1.3	50	SXU00203F
DC - 4 GHz	3.81 [.150]	3.81 [.150]	.51 [.020]	-30	0	1.3	50	SXU00303F
DC - 4 GHz	3.81 [.150]	3.81 [.150]	.51 [.020]	-20	1.5	1.3	2	SXU15203F
DC - 4 GHz	3.81 [.150]	3.81 [.150]	.51 [.020]	-30	1.5	1.3	2	SXU15303F
DC - 6 GHz	3.81 [.150]	3.81 [.150]	.51 [.020]	-20	1	1.3	2	SXU10203TF
DC - 6 GHz	3.81 [.150]	3.81 [.150]	.51 [.020]	-10	2	1.5	2	SXU20103TF

\* at 85 °C Operating Temperature





EMC Technology has over 50 years of solution based sales and engineering. From the company's inception we have been solving customer's problems with innovative products. The many patents and protected IP have driven our company to the head of the global market place. Innovations like the Thermopad®, Diamond Rf® and HybriX® product lines are a few examples of our successes. In the following pages are new and innovative products that address today's cutting edge market needs. In listening to our customers we continue to strive for smaller package size, better performance, reduce component count, market specific products and create more cost effective solutions. Please contact us if you have a special issue that requires an engineered solution.

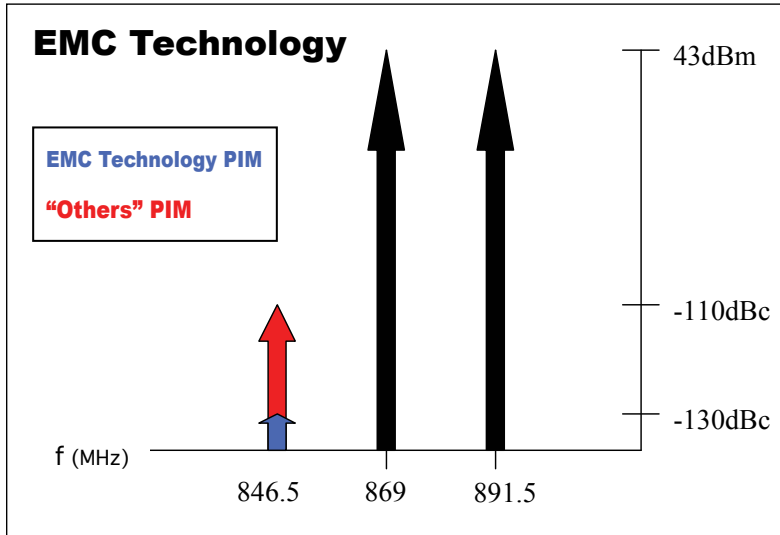


### Quick Selector Chart

Series	Page
Low PIM	90
Non-magnetic	91-92
Thermal Management	93-94



## The Only Low Passive Intermodulation Resistive Solutions in the World



### PIM matters! High PIM results in:

- Desensitized receivers
- Reduced cell capacity
- Increased inter-cell interference
- More equipment → Higher CAPEX

### Low PIM solution:

- Low PIM terminations (as low as -130dBc)
- Internally tuned for excellent VSWR
- 100% PIM tested
- Drop-in replacement for common footprints
- Integrated copper heat sink
- High power handling
- Proven performance in real-world applications
- >10 dBc better than competitors' parts

### Applications:

- 3G/4G Power Amplifiers
- Filters and Combiners
- Duplexers and Multiplexers
- Tower Mounted Antennas and Electronics
- Linearizing Networks
- Isolators and Circulators



### LOW PIM TERMINATIONS

Part Number	Power (W)	Frequency	PIM (dBc) <sup>NOTE</sup>	VSWR (x:1)	Footprint mm	Configuration	Chip Material
32P7037F	250	DC – 2.7 GHz	-115.5	1.30	24.77 x 9.53	Flange Mount	AlN
32P7196F	60	DC – 2.0 GHz	-127.0	1.25	22.10 x 9.53	Flange Mount	AlN
32P7204F	100	DC – 4.0 GHz	-124.0	1.08	13.08 x 6.35	Flange Mount	AlN
32P7197F	110	DC – 2.5 GHz	-127.0	1.20	22.10 x 9.53	Flange Mount	AlN
32P7198F	150	DC – 2.3 GHz	-123.0	1.20	22.10 x 9.53	Flange Mount	AlN
32P7201F	150	DC – 2.2 GHz	-123.0	1.25	22.10 x 9.53	Flange Mount	AlN

NOTE - With 2 x 43 dBm input



# Non-Magnetic, High Power Resistive components for MRI Market



5 W



10 W



100 W



250 W



1000 W

## Resistors, Terminations & Attenuators

- For applications with higher average power requirements
- If it's in our catalog, we can make it non-magnetic

### Ordering Information

3	1	M	1	0 0 1	0 5 0	F
<u>STYLE</u>	<u>TYPE</u>	<u>PLATING OPTION</u>	<u>SUBSTRATE MATERIAL</u>	<u>DESCRIPTIONS</u>	<u>VALUE</u>	<u>ENVIRONMENTAL COMPLIANCE</u>
3 = High Power Flange 8 = Chip/Power Pack	1 = Resistor 2 = Termination 3 = Attenuator	M = Non-magnetic	1 = BeO (Beryllium Oxide) 7 = AlN (Aluminum Nitride)	Random Numbers	Blank = Termination XXX = Resistor (ohms) XX.XX = Attenuator (dB)	F = RoHS Compliant

### Ordering Information

S M T	3 7	2 5	0 1	A I N	2	M	F
<u>STYLE</u>	<u>LENGTH</u>	<u>WIDTH</u>	<u>OPTION</u>	<u>SUBSTRATE MATERIAL</u>	<u>TOLERANCE</u>	<u>PLATING OPTION</u>	<u>ENVIRONMENTAL COMPLIANCE</u>
SMT = Surface Mount	12 = 0.12" 20 = 0.20" 25 = 0.245" 37 = 0.37"	06 = 0.06" 10 = 0.10" 25 = 0.245" 37 = 0.37"	Blank = Standard T = Tuned XX = Alternative Ground Plane	Blank = Beryllium Oxide AlN - Aluminum Nitride A = Alumina	Blank = 5% 2 = 2% 1 = 1%	M = Non-magnetic	F = RoHS Compliant



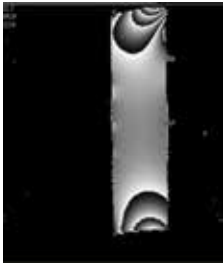


## Non-Magnetic, Signal Distribution Products For MRI Market

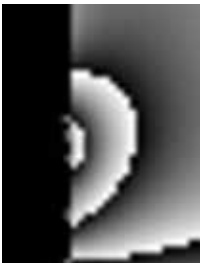
100% Tested for Magnetism - RoHS compliant

### Couplers

- Available in a low profile, SMD package for applications at 1.5T, 3T, 7T and 9.4T
- Excellent repeatability
- Reduced size over lumped elements design
- No tuning required
- Improve system reliability
- Excellent amplitude balance
- Available for transmit and receive circuits
- Excellent peak power



**3T Phantom no signature**



**Same Phantom magnetic signature**

### Crossovers

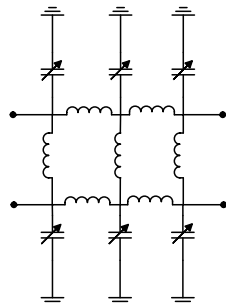
Used as bridges to connect circuit traces that must jump over another:

- Eliminate jumpers and multilayer boards
- Reduce system complexity
- High Isolation

Our products show no distortion in MRI Environments

HybriX® Couplers						
Part Number	Frequency [MHz]	Power Rating [watts]	Amplitude Balance [+/-dB max]	Insertion loss [dB Max]	Size [in]	Phase
HG064M2F	60-68	300	0.25	0.20	2.000 x 1.500	90
HD064M3F	59-69	10	0.10	1.00	0.560 x 0.350	90
BD064M3F	59-69	10	0.50	1.40	0.560 x 0.350	180
HE128MF	123-133	300	0.10	0.23	1.000 x 1.000	90
HD128M3F	123-133	10	0.20	0.80	0.560 x 0.350	90
HE298MF	293-303	300	0.10	0.17	1.000 x 1.000	90
HE450M2F	400-500	300	0.40	0.20	1.000 x 1.000	90

#### Conventional Lumped Element Approach



#### Surface-Mount Non-Magnetic Couplers



**Get rid of caps & coils!**

HybriX® Crossover					
Part Number	Frequency [MHz]	Power Rating [watts]	IL [dB]	Isolation	Size [in]
XPMRF	DC-7000	200	0.05	40	0.200 x 0.200
XFMRF	DC-10000	10	0.005	50	0.126 x 0.100

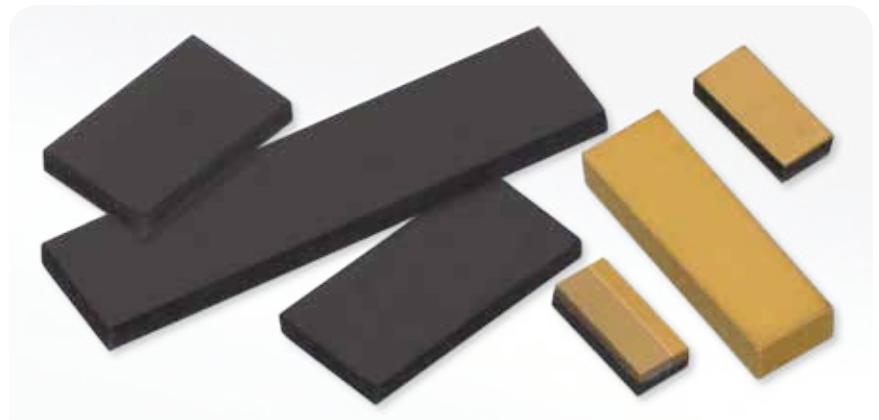


**Features**

- Up to 5x the thermal conductivity of conventional materials with CVD diamond
- Pt/Au or Ni/Au finishes
- Compatible with AuSn/AuGe solders
- Customizable

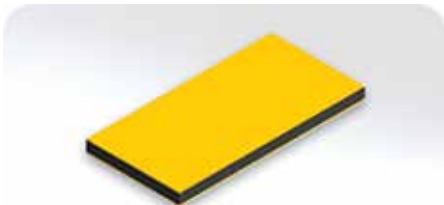
**Applications**

- GaN/GaAs RF Power Amplifiers
- DDL/DPSSL Laser Diode Arrays
- High Brightness LEDs
- High Power Switching



EMC Technology Heat Spreaders are available with CVD Diamond, Aluminum Nitride or Beryllium Oxide. Standard configuration options include Electrical isolation or conduction as well as horizontal thermal bridging. Standard solderable metallization finishes of Pt/Au or Ni/Au are available. Custom designs can also be fabricated and optimized to meet specific application requirements of size, finish, and mounting configuration.

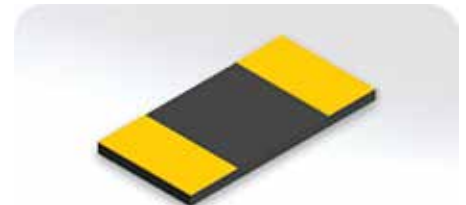
**Standard Configurations**



Electrically Isolating



Electrically Conductive

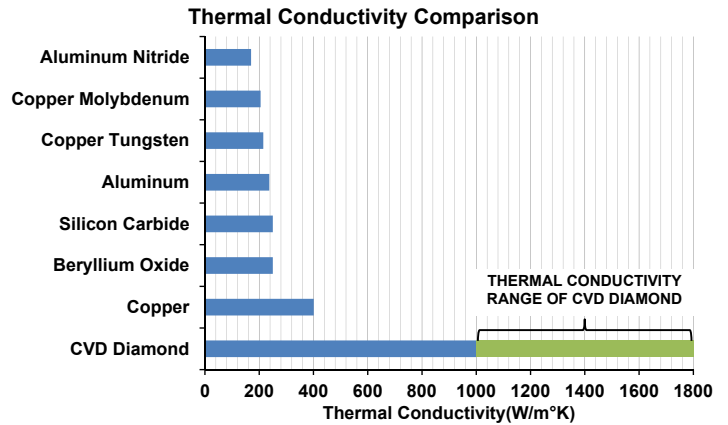
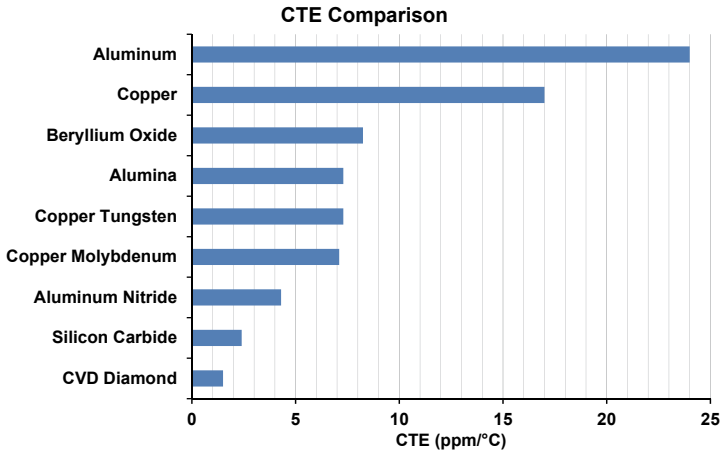


Thermal Bridging

**Part Numbering Code**

S	X	X X X	—	X X X	—	X	—	X X X
	↓	↓		↓		↓		↓
	<u>MATERIAL</u>	<u>LENGTH</u>		<u>WIDTH</u>		<u>THICKNESS</u>		<u>CONFIGURATION</u>
	A = AlN B = BeO D = Diamond	Three Digits Representing the Length in MILS  Minimum: 0.020" Maximum: 0.500" Example: 050 = 0.050" 100 = 0.100"		Three Digits Representing the Width in MILS  Minimum: 0.020" Maximum: 0.500" Example: 050 = 0.050" 100 = 0.100"		3 = 0.012" (300µm) 4 = 0.015" (381µm) 5 = 0.020" (500µm)		A = Isolated B = Conductive or Three Digits Representing the Gap Length in MILS for Bridging  Minimum: 0.005" 015 = 0.015"

### Material Comparisons



### Product Information Table

Part	Material	Configuration	Length		Width		Thickness	
			Inch	[mm]	Inch	[mm]	Inch	[mm]
SD045-025-4-A	Diamond	Isolated	0.045	[1.143]	0.025	[0.635]	0.015	[0.381]
SD055-055-4-A	Diamond	Isolated	0.055	[1.397]	0.055	[1.397]	0.015	[0.381]
SD065-035-4-A	Diamond	Isolated	0.065	[1.651]	0.035	[0.889]	0.015	[0.381]
SD105-105-4-A	Diamond	Isolated	0.105	[2.667]	0.105	[2.667]	0.015	[0.381]
SD120-080-5-A	Diamond	Isolated	0.120	[3.048]	0.080	[2.032]	0.020	[0.508]
SD130-105-4-A	Diamond	Isolated	0.130	[3.302]	0.105	[2.667]	0.015	[0.381]
SD045-025-3-B	Diamond	Conductive	0.045	[1.143]	0.025	[0.635]	0.012	[0.305]
SD045-025-4-B	Diamond	Conductive	0.045	[1.143]	0.025	[0.635]	0.015	[0.381]
SD050-020-3-B	Diamond	Conductive	0.050	[1.270]	0.020	[0.508]	0.012	[0.305]
SD055-055-3-B	Diamond	Conductive	0.055	[1.397]	0.055	[1.397]	0.012	[0.305]
SD055-055-4-B	Diamond	Conductive	0.055	[1.397]	0.055	[1.397]	0.015	[0.381]
SD065-035-3-B	Diamond	Conductive	0.065	[1.651]	0.035	[0.889]	0.012	[0.305]
SD065-035-4-B	Diamond	Conductive	0.065	[1.651]	0.035	[0.889]	0.015	[0.381]
SD105-105-3-B	Diamond	Conductive	0.105	[2.667]	0.105	[2.667]	0.012	[0.305]
SD105-105-4-B	Diamond	Conductive	0.105	[2.667]	0.105	[2.667]	0.015	[0.381]
SD130-105-3-B	Diamond	Conductive	0.130	[3.302]	0.105	[2.667]	0.012	[0.305]
SD130-105-4-B	Diamond	Conductive	0.130	[3.302]	0.105	[2.667]	0.015	[0.381]

Part	Material	Configuration	Length		Width		Thickness		Gap Length	
			Inch	[mm]	Inch	[mm]	Inch	[mm]	Inch	[mm]
SD045-025-4-015	Diamond	Bridging	0.045	[1.143]	0.025	[0.635]	0.015	[0.381]	0.015	[0.381]
SD055-055-4-015	Diamond	Bridging	0.055	[1.397]	0.055	[1.397]	0.015	[0.381]	0.015	[0.381]
SD065-035-4-025	Diamond	Bridging	0.065	[1.651]	0.035	[0.889]	0.015	[0.381]	0.025	[0.635]
SD105-105-4-035	Diamond	Bridging	0.105	[2.667]	0.105	[2.667]	0.015	[0.381]	0.035	[0.889]
SD130-105-4-040	Diamond	Bridging	0.130	[3.302]	0.105	[2.667]	0.015	[0.381]	0.040	[1.016]

EMC Technology continues to offer legacy products for our customers to support existing designs and older programs. This section contains products that have reached maturity and still have relevance to our customers. In the following pages you will find popular products that have survived the test of time. Flush mount terminations, pill terminations and film cards that are still available as standard product lines. If you do not see a product that you are searching for in this section please visit our web site at [emc-rflabs.com](http://emc-rflabs.com) or contact our sales department at [sales@emc-rflabs.com](mailto:sales@emc-rflabs.com) (772) 286-9300.



**Quick Selector Chart**

Series	Page
Switch Terminations	96
Coaxial Remote Terminations	97
Pill Terminations	98
Film Cards	99

# Switch Termination

## Product Information

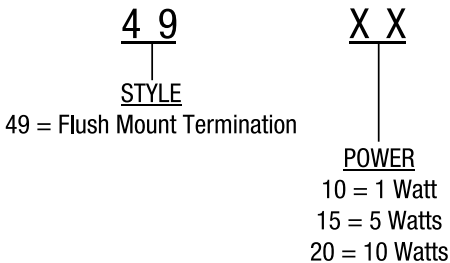


Switch terminations (sometimes referred to as 'flush mount terminations') are designed to maximize power in a small size. These devices are well suited for applications where size and weight saving are a consideration. The flush mount termination utilizes a female SMA thread for connection to circuits. The contacts are designed for repeatable and continuous connections with the circuit contact.

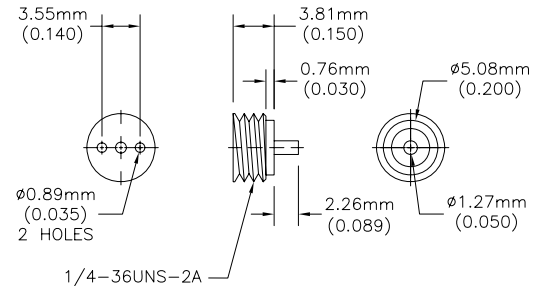
## Specifications

Impedance	50 Ohms +/-5%
Connector	SMA Female , 3.5mm, 2.9mm
Frequency Range	DC to 18 Ghz
VSWR	1.3 Max
Power	1 to 3 Watts
Power Rating	100% @ 100°C
Derates to	0% @ 150 °C
Operating Temperature	-55 °C to 150 °C
Resistor	Thin Film
Substrate	BeO or Alumina
Body	Stainless Steel or Brass (4920)
Body Finish	Passivated or Nickel Plated (4920)
Contact	Beryllium Copper
Contact Finish	Gold

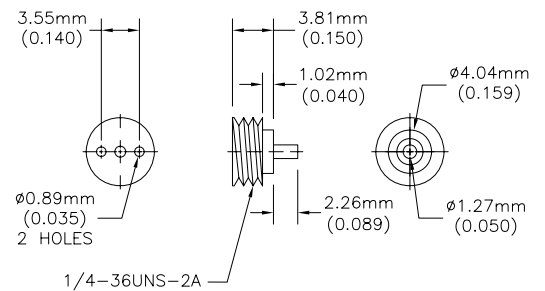
## Part Numbering Code



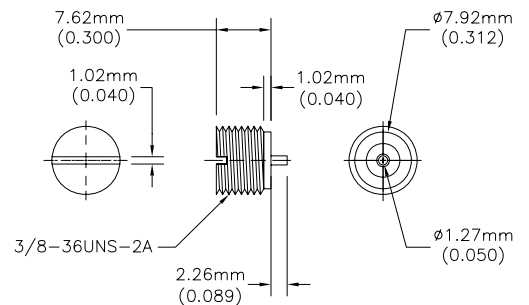
### Model 4910 - 1 Watt



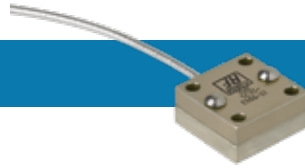
### Model 4915 - 5 Watts



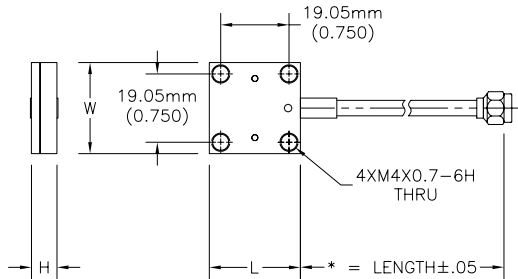
### Model 4920 - 10 Watts





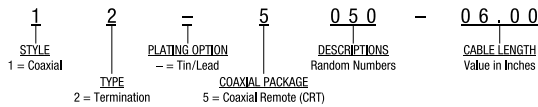


### 12 Series CRT



\* LENGTH VARIES BY CUSTOMER SPECIFICATIONS.

### Part Numbering Code



For applications where a high power termination is required to be remotely located, the series Coaxial Remote Terminations feature integral coaxial cable inputs. They also offer ultra low VSWR. These devices decrease the number of interconnections in your system at reduced cost over a discrete cable and termination or attenuator approach.

### Specifications

Resistance	50 Ohms +/-5%
Cable Length	4 to 28 inches
Power	20 to 500 Watts
Frequency Range	DC to 6 GHz
Power Rating	100% @ 100°C at the heatsink
Derates to	0% @ 150 °C
Operating Temperature	-55 °C to 150 °C
Standard Connectors	SMA and Type N*
Substrates	BeO or AlN
Resistive Element	Thin Film
Housing Base	Aluminum, Tri-Metal Plated
Housing Cover Cable	Aluminum, Iridited
Cable	Braided Jacket, Hand-Formable *
Coaxial Connector	SMA Male Connector *
Connector Body	Stainless Steel, Gold Plated
Center Contact	Copper Weld, Silver Plated
Coupling Nut	Stainless Steel, Passivated

\* Other cables, & connector types available upon request. Also Polyolefin (shrink tubing) jacket

Power Watt	Frequency GHz	VSWR Max	Substrate	L		W		H		Part Series #
				mm	[inches]	mm	[inches]	mm	[inches]	
20	10.0	1.35	BeO	10.16	[0.400]	12.70	[0.500]	8.51	[0.335]	12-5028
60	2.0	1.08	AlN	22.00	[0.866]	22.00	[0.866]	10.16	[0.400]	12-5042
60	8.0	1.35	BeO	15.24	[0.600]	17.78	[0.700]	7.62	[0.300]	12-5032
60	5.0	1.40	BeO	22.00	[0.866]	22.00	[0.866]	10.16	[0.400]	12-5007
150	2.0	1.10	AlN	22.00	[0.866]	22.00	[0.866]	10.16	[0.400]	12-5050
150	2.0	1.20	BeO	24.49	[0.964]	24.49	[0.964]	10.16	[0.400]	12-5049
150	2.0	1.20	BeO	22.00	[0.866]	22.00	[0.866]	10.16	[0.400]	12-5029
150	2.0	1.10	BeO	15.24	[0.600]	17.78	[0.700]	8.89	[0.350]	12-5021
150	2.0	1.40	BeO	24.49	[0.964]	24.49	[0.964]	10.16	[0.400]	12-5014
150	2.0	1.10	BeO	22.00	[0.866]	22.00	[0.866]	10.16	[0.400]	12-5013
150	2.0	1.10	BeO	24.49	[0.964]	24.49	[0.964]	10.16	[0.400]	12-5012
150	2.0	1.10	BeO	24.49	[0.964]	24.49	[0.964]	10.16	[0.400]	12-5005
250	2.0	1.08	BeO	25.40	[1.000]	25.40	[1.000]	7.11	[0.280]	12-5051
500	2.5	1.20	BeO	25.40	[1.000]	25.40	[1.000]	7.11	[0.280]	12-5061

Power ratings are based on 100°C heat sink, except for CT2335A, which is 85°C

\*\*\* is a place holder for cable length in inches.

# Pill Terminations

## Stripline Pill

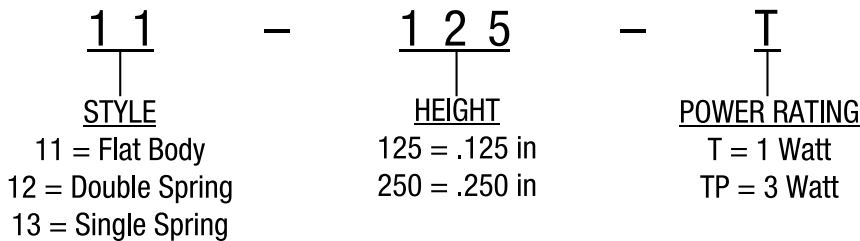


Our Stripline Pill Terminations are available in several different ground plane spacings and solderless construction. The resistive rod element is staked into the case forming a highly reliable compression fit. The result is a superior product which is unaffected by subsequent high temperature manufacturing processes.

### Specifications

Impedance	50 Ohms +/-5%
Frequency Range	DC to 26.5 Ghz
VSWR	1.30 Max
Power Rating	100% to 125 °C
Derates to	0% @ 150 °C
Operating Temperature	-55 °C to 150 °C
Resistive Material	Thin Film

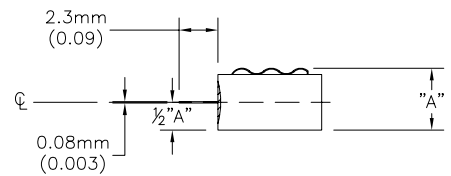
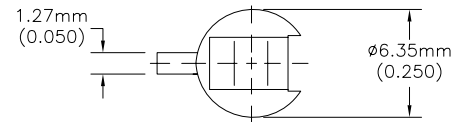
### Part Numbering Code



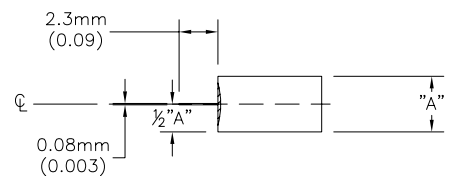
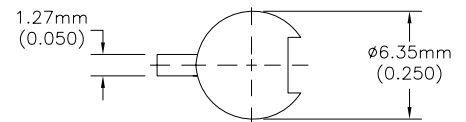
Power Watt @ 25° C	Spring	Maximum Peak Power (W)*	"A" Thickness		Figure #	Part Series #
			[mm]	inches		
1	None	100	[3.18]	0.1250	1	11-125-T
1	None	100	[6.35]	0.2500	1	11-250-T
1	Double	100	[3.18]	0.1250	2	12-125-T
1	Double	100	[6.35]	0.2500	2	12-250-T
1	Single	100	[3.18]	0.1250	3	13-125-T
1	Single	100	[6.35]	0.2500	3	13-250-T
3	None	100	[3.18]	0.1250	1	11-125-TP
3	None	100	[6.35]	0.2500	1	11-250-TP
3	Double	100	[3.18]	0.1250	2	12-125-TP
3	Double	100	[6.35]	0.2500	2	12-250-TP
3	Single	100	[3.18]	0.1250	3	13-125-TP
3	Single	100	[6.35]	0.2500	3	13-250-TP

\* Peak power based on 100ms pulse width and 0.1% duty cycle

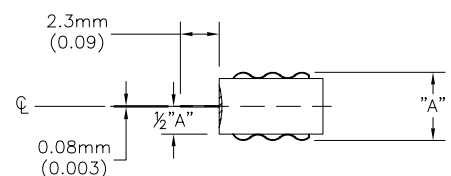
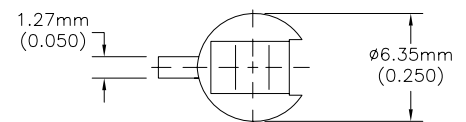
### Pill - Single Spring



### Pill - Flat Body (No Spring)

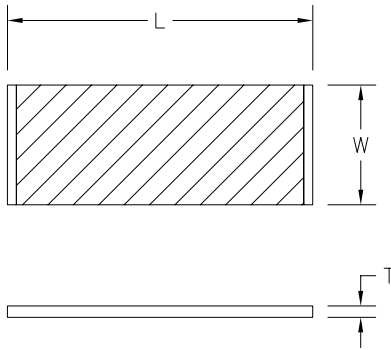


### Pill - Double Spring





### Film Card



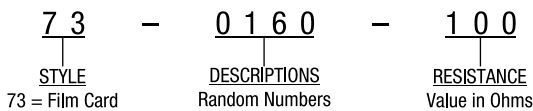
We offer a complete line of standard and custom wave-guide attenuator elements. Deposition of thin film metallization on a glass substrate with an optical grade finish produces an extremely stable resistive film. A protective coating is evaporated over the resistive film to prevent oxidation. Controlled processes throughout produce guaranteed repeatability.

Film cards are available in four materials: Fiberglass, Mylar®, Kapton® or Mica. They feature a surface resistance range of 25 to 1k ohm per square and power handling up to 8 watts. Applications include: Waveguide Elements, Crystal Detector Protection, Directional Coupler Termination and Mode Suppression in Cavity Filters.

Contact the Sales Department for custom design requirements.

*Mylar® and Kapton® are registered trademarks of E. I. du Pont de Nemours and Company.*

### Part Numbering Code



### General Specifications

Resistance Range	25 to 1k Ohms/Square
Standard Tolerance	10%
Dielectric	3.3 @ 60Hz
Max Surface Temperature	150 °C (Fiberglass is 130 °C)
Power Rating	100% @ 125 °C, 0% @ 150 °C
Operating Temperature	-55 °C to 150 °C
Resistive Material	Thin Film
Substrates	Fiberglass, Mylar®, Kapton®, Mica
Fiberglass Dielectric	4.8 @ 1 MHz
Mylar® Dielectric	3.3 @ 60 MHz
Kapton® Dielectric	3.9 @ 1Hz
Mica Dielectric	6.0 @ 1Hz

Substrate	L		W		T		Part Series #
	mm [inches]						
Fiberglass	304.80	[12.000]	127.00	[5.000]	0.25	[0.010]	73-0160
Fiberglass	304.80	[12.000]	127.00	[5.000]	0.64	[0.025]	73-0161
Fiberglass	304.80	[12.000]	127.00	[5.000]	0.81	[0.032]	73-0162
Fiberglass	304.80	[12.000]	127.00	[5.000]	1.57	[0.062]	73-0163
Kapton®	304.80	[12.000]	127.00	[5.000]	0.05	[0.002]	73-0167
Kapton®	304.80	[12.000]	127.00	[5.000]	0.13	[0.005]	73-0168
Mica	127.00	[5.000]	50.80	[2.000]	0.05	[0.002]	73-0154
Mica	127.00	[5.000]	50.80	[2.000]	0.08	[0.003]	73-0155
Mica	127.00	[5.000]	50.80	[2.000]	0.13	[0.005]	73-0156
Mylar®	304.80	[12.000]	127.00	[5.000]	0.03	[0.001]	73-0157
Mylar®	304.80	[12.000]	127.00	[5.000]	0.13	[0.005]	73-0158
Mylar®	304.80	[12.000]	127.00	[5.000]	0.01	[0.010]	73-0159
Mylar®	304.80	[12.000]	127.00	[5.000]	0.05	[0.002]	73-0166

## ***Legacy Product Family***

Notes

# Standard High Reliability Test Flow for RF Components

## Additional RF Component Testing Available:

Stability of Attenuation After:

- Temperature Change
- Thermal Shock
- Vibration
- Shock
- Moisture Resistance
- Peak Power
- Salt Spray

Sensitivity of Attenuation After:

- Change in Input Power
- Change in Frequency
- Change in Temperature

Vibration and Shock Testing

Moisture Resistance

Peak Power

Salt Spray

Barometric Pressure

Outgassing

Endurance

Resistance to Bonding Exposure

Low Temperature Operation

Short Term Overload

High Temperature Exposure

Solderable Mounting Integrity

Bondable Mounting Integrity

Resistance to Solvents

Gross and Fine Leak Detection

Multipaction Testing

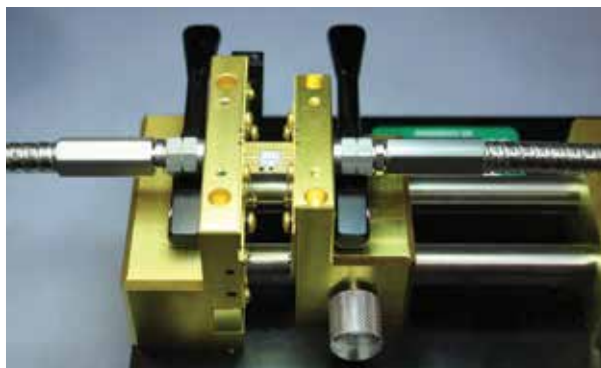
Radiographic Inspection

First Article Inspection

Pre-Cap Inspection

Source Inspection

Other testing services are available upon request.



## GROUP A TESTING AND INSPECTION (100% of the lot)

Pre-cap Visual Inspection

Conductor Metallization Defects

Resistor Defects

Substrate Defects

Foreign Material

Visual Mechanical Inspection

Electrical Inspections

Electrical Performance

Thermal Shock

Electrical Performance

Burn-In [100% 168 hours at input power]

Final RF Test

Percent Defective Allowable (PDA)

Temperature Coefficient of Attenuation

## GROUP B TESTING AND INSPECTION (Sample)

Subgroup 1 (sample)

Low Temperature Operation

Electrical Performance

High Temperature Bake

Visual Mechanical Inspection

Electrical Performance

Termination Adhesion (Planar, W1, W3 only)

Bondability (WB1 and G only)

Termination Solderability

(Planar, W1, W3, T3 and T3S only)

Terminal Lead Strength (T3 and T3S only)

Subgroup 2 (sample)

Electrical Performance

Life Test. Sample units for 1000 hours at the maximum input power specified

Electrical Performance

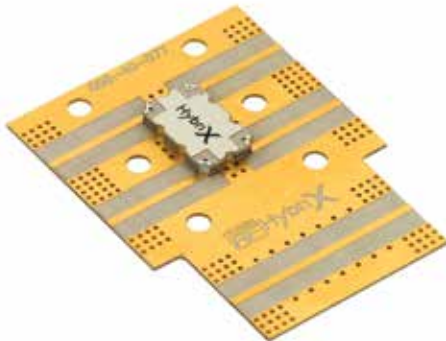
## GROUP C TESTING AND INSPECTION (Sample)

Electrical Performance

Load Life. Burn-in units at 125°C for duration of 1000 hours at maximum input power specified.

Electrical Performance

Data Review and Data Pack



EMC Technology offers Engineering Design Kits and Product Kits that are ideal for designers who need fast, convenient and accurate products for microwave circuits. Below is a list of our most popular kits. In addition evaluation boards are available for many of our products. Please contact the Sales Department if you have an application that requires a custom kit or an evaluation board.

### Engineering Design Kits

TVA Kit 35 of each of 15 TVA's of various dB and TCA values  
MTVA Kit 35 of each of 14 MTVA's and 2 HTVA's of various dB and TCA values  
K-Band Kit 10 of each of 5 KTVA's and 11 KFA's of various dB and TCA values  
TS03 Kit 25 of each of 1 to 10 dB, 12, 14, 16, 18, and 20 dB  
TS05 Kit 25 of each of 1 to 10 dB, 12, 14, 16, 18, and 20 dB  
TS05 Triple Wrap Kit 25 of each of 1 to 10 dB, 12, 14, 16, 18, and 20 dB  
TS07 Kit 25 of each of 0 to 3, 6 and 10 dB  
CVD Diamond Kit 3 of each of 12 styles of terminations and resistors  
HybriX®3 Kit 10 of each of 4 styles hybrid and 4 styles directional LTCC couplers

### Product Kits

TS03 Kit 5 of each of 1 to 10 dB values - planar terminal style  
TS03 Triple Wrap Kit 5 of each of 1 to 10 dB values - triple wrap terminal style  
TS05 Kit 5 of each of 1 to 10 dB values - planar terminal style  
TS05 Triple Wrap Kit 5 of each of 1 to 10 dB values triple wrap terminal style  
TS05 Triple Wrap, Solder Terminal Kit 5 of each of 1 to 10dB values - triple wrap, solder terminal style  
TS05 Gold Terminal Kit 5 of each of 1 to 10 dB values - gold terminal style  
TS05 Wire Bond Gold Kit 5 of each of 1 to 10 dB values - wire bond gold style  
TS07 Kit 25 of each of 0, 3, 6, 10 dB values - planar terminal style  
TS09 Kit 5 of each of 0, 3, 6, 10 dB - surface mount style  
WTVA Kit 5 of each of 5 WTVA 2-6 dB and -006 TCA values - wire bond gold style  
WTVA Kit 5 of each of 4 WTVASMTF 3-6 dB and -007 TCA values - surface mount style

### Custom Kits

AN7-Custom Kit 25 of 5 stocked AN7 Planar of customers choice  
MTVAS-Custom Kit 25 of 12 stocked MTVA Planar of customers choice  
MTVAW3-Custom Kit 25 of 12 stocked MTVA Triple Wrap of customers choice  
TS03 Triple Wrap Custom Kit 25 of 12 stocked TS03 Triple Wrap of customers choice



### Lab-Flex® Cable Assemblies to 65 GHz FIELD PROVEN

- Low loss dielectric construction provides up to 40% less loss
- Custom braids that provide superior mechanical strength and shielding greater than 90 dB
- Stainless steel connector constructions that are also water resistant
- Wide variety of protective coverings for demanding environments
- Employs our unique Solder Sleeve connector design for superior connector retention
- Stranded center conductor version Lab-Flex®S, up to 65 GHz



### Lab-Flex® AF Cable Assemblies to 40 GHz HARSH ENVIRONMENT

- Low loss flexibles for demanding airborne, shipboard & ground-based environments
- Triple-shielded cable design protected by an abrasion resistant jacket
- Design has been tested and qualified to meet or exceed MIL-T-81490 & MIL-C-87104
- Redundant sealing system design for both cable and connectors



### Lab-Flex® Q Cable Assemblies to 40 GHz SPACE APPLICATION DESIGNS

- All assemblies meet stringent NASA outgassing requirements.
- Space Cable designs have vented connectors for Thermal Breakdown and Multipaction
- Tefzel Jacket material for maximum radiation resistance
- 78% to 83% velocity ePTFE dielectric core for low loss
- High Reliability Testing Capability



### ASR Cable Assemblies to 50 GHz For Precision Test Measurements

- High performance VNA Test Port assemblies
- ASR maintains its mechanical configuration
- ASR-F is a flexible alternative to the original ASR design
- Available with 2.4mm & 2.92mm NMD connectors
- Can be supplied individually or in phase-matched pairs



### Titan-Flex™ Cable Assemblies to 18 GHz Mechanical Strength

- Upgrade your standard RG cables with cost effective Titan-Flex™
- Robust solder termination design for superior electrical performance
- Improved mechanical strength and durability with steel center conductor
- 2 flat braids and a sinter PTFE dielectric for better crush resistance
- Fitting .141 S/R connector designs, electrical performance is consistent and optimized to 18 GHz

# Index

<b>1x xxx</b>	Pill Terminations.....	<b>98</b>
<b>12 xxxx</b>	Coaxial Remote Terminations.....	<b>97</b>
<b>31 xxxx</b>	Flange Resistors.....	<b>60</b>
<b>32 xxxx</b>	Flange Terminations .....	<b>44</b>
<b>33 xxxx</b>	Flange Fixed Attenuators.....	<b>31</b>
<b>41xx</b>	Coaxial Terminations .....	<b>53</b>
<b>42 xxx</b>	Coaxial Fixed Attenuators.....	<b>36</b>
<b>42TVAXxxxxxx</b>	Coaxial Temperature Variable Attenuators .....	<b>14</b>
<b>49xx</b>	Switch Terminations.....	<b>96</b>
<b>5xxxxxxx</b>	Flange Resistors.....	<b>60</b>
<b>5xxx</b>	Flange Terminations .....	<b>44</b>
<b>73 xxxx</b>	Film Cards .....	<b>99</b>
<b>8 xxx</b>	Stripline Flange Terminations .....	<b>50</b>
<b>81 xxxx</b>	Chip Resistors .....	<b>56</b>
<b>81 xxxxTC</b>	Tab & Cover Resistors.....	<b>58</b>
<b>82 xxxxTC</b>	Tab & Cover Terminations.....	<b>42</b>
<b>83 xxxx</b>	Chip Fixed Attenuators .....	<b>26</b>
<b>83 xxxxTC</b>	Tab & Cover Fixed Attenuators.....	<b>28</b>
<b>ANx</b>	Temperature Variable Attenuators .....	<b>10</b>
<b>CAxxxxD</b>	Diamond Fixed Attenuators .....	<b>66</b>
<b>CRxxxxD</b>	Diamond Resistors .....	<b>69</b>
<b>CTxxxx</b>	High Power Chip Terminations .....	<b>40</b>
<b>CTxxxxD</b>	Diamond Terminations.....	<b>72</b>
<b>Dxxxxx</b>	Directional Couplers .....	<b>79</b>



<b>ETVA</b>	Extended Shift Temperature Variable Attenuators .....	<b>13</b>
<b>Hxxxx</b>	Hybrid Couplers .....	<b>75</b>
<b>HPCA</b>	High Power Chip Fixed Attenuators .....	<b>25</b>
<b>HR0x</b>	High Reliability Chip Fixed Attenuators .....	<b>35</b>
<b>HRMTVA</b>	High Reliability Mini Temperature Variable Attenuators .....	<b>16</b>
<b>HRTVA</b>	High Reliability Temperature Variable Attenuators.....	<b>15</b>
<b>KFA</b>	K Band Fixed Attenuators .....	<b>20</b>
<b>KTVA</b>	K Band Temperature Variable Attenuators.....	<b>8</b>
<b>MTVA</b>	Mini Temperature Variable Attenuators .....	<b>6</b>
<b>Pxxxxx</b>	Power Dividers.....	<b>85</b>
<b>QFA</b>	Q Band Fixed Attenuators .....	<b>21</b>
<b>QTVA</b>	Q Band Temperature Variable Attenuators .....	<b>9</b>
<b>RPDxxxx</b>	Resistive Power Dividers .....	<b>87</b>
<b>SMTxxxxx</b>	Surface Mount Terminations .....	<b>38</b>
<b>SXUxxx</b>	Power Samplers .....	<b>88</b>
<b>TRx x-xx</b>	Rod Resistors .....	<b>63</b>
<b>TS0x</b>	Chip Fixed Attenuators .....	<b>22</b>
<b>TVA</b>	Temperature Variable Attenuators .....	<b>5</b>
<b>WHxxxxx</b>	Wideband Couplers .....	<b>76</b>
<b>WTV</b>	Wideband Temperature Variable Attenuators .....	<b>7</b>
<b>Xxxxx</b>	Crossovers.....	<b>84</b>

# Global Support

## UK Headquarters

- London, UK  
+44 20 7004 1600  
info.uk@smithsinterconnect.com

## US Headquarters

- Stuart, FL  
+1 772 286 9300  
info.us@smithsinterconnect.com

## Americas

- Costa Mesa, CA  
+1 714 371 1100  
info.us@smithsinterconnect.com
- Milpitas, CA  
+1 408 957 9607 x 1125  
info.us@smithsinterconnect.com
- Stuart, FL  
+1 772 286 9300  
info.us@smithsinterconnect.com
- Hudson, MA  
+1 978 568 0451  
info.us@smithsinterconnect.com
- Northampton, MA  
+1 413 582 9620  
info.northampton@smithsinterconnectinc.com
- Tampa, FL  
+1 813 901 7200  
info.tampa@smithsinterconnectinc.com
- Kansas City, KS  
+1 913 342 5544  
info.us@smithsinterconnect.com
- Salisbury, MD  
+1 800 780 2169  
info.us@smithsinterconnect.com
- Thousand Oaks, CA  
+1 805 267 0100  
info.thousandoaks@smithsinterconnectinc.com

## Europe

- Deggendorf, Germany  
+49 991 250 120  
info.de@smithsinterconnect.com
- Genoa, Italy  
+39 0 10 60361  
info.it@smithsinterconnect.com
- Dundee, UK  
+44 1382 427 200  
info.dundee@smithsinterconnect.com
- Rouen, France  
+33 2 32 96 91 76  
info.fr@smithsinterconnect.com
- Elstree, UK  
+44 20 8236 2400  
info.uk@smithsinterconnect.com

## Asia

- Shanghai, China  
+86 21 2283 8008  
info.asia@smithsinterconnect.com
- Suzhou, China  
+86 512 6273 1188  
info.asia@smithsinterconnect.com
- Miayang, China  
+86 816 231 5566  
HSICSR@hf-smiths.com
- Singapore  
+65 6846 1655  
info.asia@smithsinterconnect.com



[smithsinterconnect.com](https://smithsinterconnect.com)



Copyright © 2020 Smith Interconnect | All right reserved | Version 1.0

## Disclaimer

All of the information included in this catalogue is believed to be accurate. It is recommended, however, that users should independently evaluate the suitability of each product for their intended application and be sure that each product is properly installed, used and maintained to achieve desired results.

Smiths Interconnect makes no warranties as to the accuracy or completeness of the information, and disclaims any liability regarding its use.

Smiths Interconnect reserves the right to modify design and specifications, in order to improve quality, keep pace with technological development or meet specific production requirements.

No reproduction or use without express permission of editorial and pictorial content, in any manner.